



**PARTS
CATALOGUE
CATALOGO
DE REPUESTOS**

E9.9DMH'12 (6B39)

E15DMH'12 (6B49)



1L6B3-200S1

()

E9.9DMH/E15DMH
PARTS CATALOGUE
©2011 by Yamaha Motor Co., Ltd.
1st edition, October 2011
All rights reserved.
Any reprinting or unauthorized use
without the written permission of
Yamaha Motor Co., Ltd.
is expressly prohibited.
Printed in Japan.

E9.9DMH/E15DMH
CATALOGO DE REPUESTOS
©2011 por Yamaha Motor Co., Ltd.
1ª edición, octubre 2011
Todos los derechos reservados.
Toda reproducción o uso no autorizado
sin el consentimiento escrito de
Yamaha Motor Co., Ltd.
quedan expresamente prohibidos
Impreso en Japón.

FOREWORD

This Parts Catalogue is related to the parts for the model(s) on the cover page. When you are ordering replacement parts, please refer to this Parts Catalogue and quote both part numbers and part names correctly.

1. Modifications or additions which have been made after the issue of the Parts Catalogue will be announced in the Parts News.
It is advisable that you make the necessary corrections to the Parts Catalogue according to the Parts News.

2. Abbreviations

The following abbreviations are used in this Parts Catalogue.

“UR” Use specified parts number.

“UN” Use as many as needed.

“AP” Alternate Parts

“LM” Locally Made (Parts need to be ordered locally)

“F#” Frame No. (Applicable machine No.)

“O/S” Over Size

3. The number of components for assembly

- Parts, which are to be supplied in an assembly, are listed with a dot (.) in front of the part name as shown below.
- The numeral appearing to the right of each component part indicates the quantity of parts for each assembly unit.

PART NO.	DESCRIPTION	Q'TY	REMARKS
2F5-83310-60	FRONT FLASHER LIGHT ASSY	2	
115-83311-60	.BULB (6V-18W)	1	

4. Applicable colours of graphics are represented in the “REMARKS” as shown below.

PART NO.	DESCRIPTION	Q'TY	REMARKS
2N4-24110-00-X5	FUEL TANK COMP.	2	MXR
3J1-24240-10	.GRAPHIC, FUEL TANK	1	FOR MXR

5. Note that the illustrations for reference in finding parts numbers are not to be used for assembling. When assembling, please use the applicable service manual.

6. The asterisk (*) before a reference number indicates modified items after the first edition.

7. Applicable Serial No.

Engine Serial No.

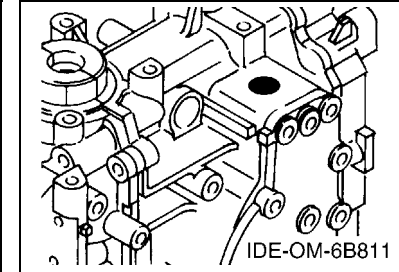
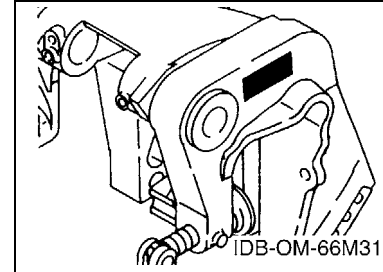

8. Applicable Engine Starting Serial No.

Model	Serial No.	Model	Serial No.
E9.9D	6B3K-1010915	E15D	6B4K-1141562

9. Applicable Colour Code

Abbreviation	Colour Name	Colour Code
DBNM2	DARK BLUISH GRAY METALLIC 2	004D

10. Quantity Column Information

Column No.	Name Of Q'ty Column	Applicable Model
1	6B39	E9.9DMH
2	6B49	E15DMH

PROLOGO

Este catálogo de repuestos corresponde a las piezas para el o los modelos que figuran en la página de portada. Al formular el pedido de repuestos, se ruega citar este catálogo y especificar correctamente el número y el nombre de las piezas.

- Las modificaciones y agregados que se hayan realizado después de la edición de este Catálogo de Repuestos, serán anunciados en las Informaciones de Recambios. Es recomendable que se hagan las correcciones necesarias en el Catálogo de Repuestos de acuerdo con las Informaciones de Recambios.

2. Abreviaciones

En este. Catálogo de Repuestos se emplean las siguientes abreviaciones.

“UR” Usar el número de partes especificado

“UN” Usar la cantidad necesaria

“AP” Piezas sustitutivas

“LM” Fabricación local (Hay que pedir los repuestos en las cercanías)

“F#” N° de bastidor (N° aplicable a la máquina)

“O/S” Sobredimensionado

3. La cantidad de componentes para el montaje

- Los componentes, suministrados como conjunto, se describen con un punto (.) que precede al nombre del parte como se indica a continuación.
- La numeración que aparece a la derecha de cada descripción indica la cantidad de partes por cada unidad de conjunto.

CODIGO N°	DESCRIPCION	CANT.	OBSERVACIONES
2F5-83310-60	ENSAMBLAJE DE LA LUZ	2	
115-83311-60	.BOMBILLA (6V-18W)	1	

4. Los colores de los componentes se indican como sigue en la columna de “OBSERVACIONES”.

CODIGO N°	DESCRIPCION	CANT.	OBSERVACIONES
2N4-24110-00-X5	COMP. DEL TANQUE	2	MXR
3J1-24240-10	.GRAFICO, DEL TANQUE	1	PARA MXR

- Debe tenerse en cuenta que las ilustraciones sirven como guía para la búsqueda de los números de partes y no deben usarse para el montaje. Durante el montaje, se recomienda usar el manual de taller correspondiente.

- EL asterisco (*) antes del número de referencia indica los elementos modificados después de la primera edición.

7. Números de serie

N° de Serie del motor

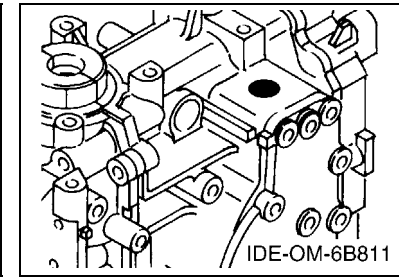
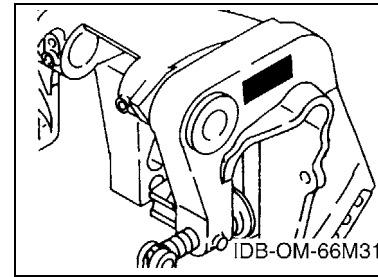

8. Números de serie del motor

Modelo	N° de serie	Modelo	N° de serie
E9.9D	6B3K-1010915	E15D	6B4K-1141562

9. Códigos de color aplicables

Abreviatura	Nombre de color	Código de color
DBNM2	DARK BLUISH GRAY METALLIC 2	004D

10. Informacion para la columna de cantidades

Columna N°	Nombre de la columna de cantidades	Modelo aplicable
1	6B39	E9.9DMH
2	6B49	E15DMH

CONTENTS

TOP COWLING	1
CYLINDER & CRANKCASE	2
CRANKSHAFT & PISTON	4
INTAKE	6
CARBURETOR	7
FUEL	9
STARTER	10
GENERATOR	12
ELECTRICAL	13
BOTTOM COWLING	14
STEERING	15
CONTROL	16
BRACKET 1	18
BRACKET 2	21
UPPER CASING	23
LOWER CASING & DRIVE 1	25
LOWER CASING & DRIVE 2	28
FUEL TANK	30
OPTIONAL PARTS	31
REPAIR KIT 1	32
REPAIR KIT 2	33

INDEX

NUMERICAL INDEX	34
-----------------------	----

CONTENIDO

SOPORTE SUPERIOR	1
CYLINDRO & CARTER	2
CIGUENAL & PISTON	4
ADMISION	6
CARBURADOR	7
COMBUSTIBLE	9
ARRANQUE	10
GENERADOR	12
ELECTRICO	13
CUBIERTA INFERIOR	14
DIRECCION	15
CONTROL	16
SOPORTE 1	18
SOPORTE 2	21
FUNDA SUPERIOR	23
IMPULSOR E INFERIOR 1	25
IMPULSOR E INFERIOR 2	28
DEPOSITO DE COMBUSTIBLE	30
PARTES OPCIONALES	31
ESTUCHE REPARATION 1	32
ESTUCHE REPARATION 2	33
INDICE	
INDICE NUMERICO	34

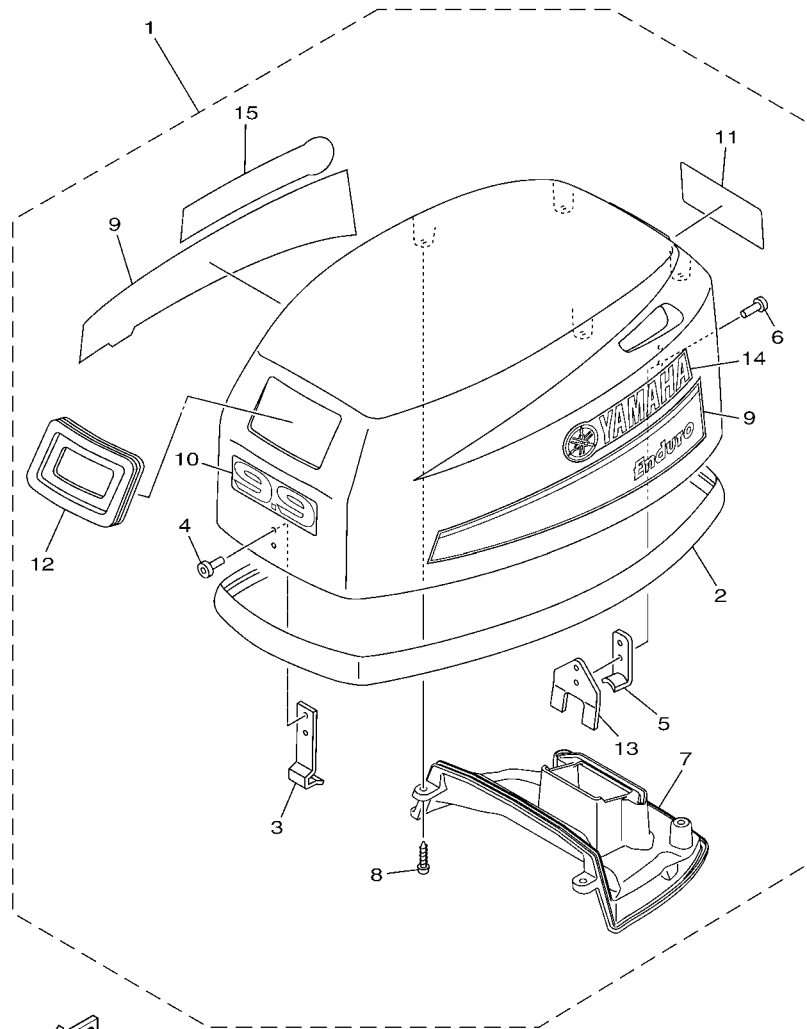

6B39200-L010

FIG. 1 TOP COWLING

SOPORTE SUPERIOR

REF. NO.	PART NO. CODIGO Nº	DESCRIPTION DESCRIPCION	6B39	6B49		REMARKS OBSERVACIONES
1	6B3-42610-20	TOP COWLING ASSY SOPORTE SUPERIOR COMPL.	1			
	6B4-42610-40	TOP COWLING ASSY SOPORTE SUPERIOR COMPL.		1		
	6B4-42610-50	TOP COWLING ASSY SOPORTE SUPERIOR COMPL.		1		FOR IDN FOR IDN
2	6B4-42615-00	.SEAL .SELLO	1	1		
3	6B4-42651-00	.HOOK .GANCHO	1	1		
4	90266-04M00	.RIVET .REMACHE	2	2		
5	6B4-42647-00	.HOLDER, CLAMP BAND .MORDAZA DE ABRAZADERA	1	1		
6	90266-04005	.RIVET .REMACHE	2	2		
7	6B4-42613-10	.MOLDING, AIR DUCT .MOLDURA CONDUCTO AIRE	1	1		
8	97780-50616	.SCREW, TAPPING .TORNILLO DE CABEZA DE CONO ACH	4	4		
9	677-W0070-10	.GRAPHIC SET .JUEGO DE EMBLEMA	1	1		
10	63V-42678-40	.GRAPHIC, REAR .CALCAMONIA TRASERA	1			
	63W-42678-40	.GRAPHIC, REAR .CALCAMONIA TRASERA		1		
11	63V-42678-40	.GRAPHIC, REAR .CALCAMONIA TRASERA	1			
	63W-42678-40	.GRAPHIC, REAR .CALCAMONIA TRASERA		1		
12	6B4-15761-00	.SEAL, RUBBER 1 .SELLO DE GOMA 1	1	1		
13	6B4-42646-00	.PLATE, CLAMP .PLACA GRAMPA	1	1		
14	6E0-42681-40	.MARK, COWLING .MARCA DE CUBIERTA	1	1		
15	6E0-42681-40	.MARK, COWLING .MARCA DE CUBIERTA	1	1		

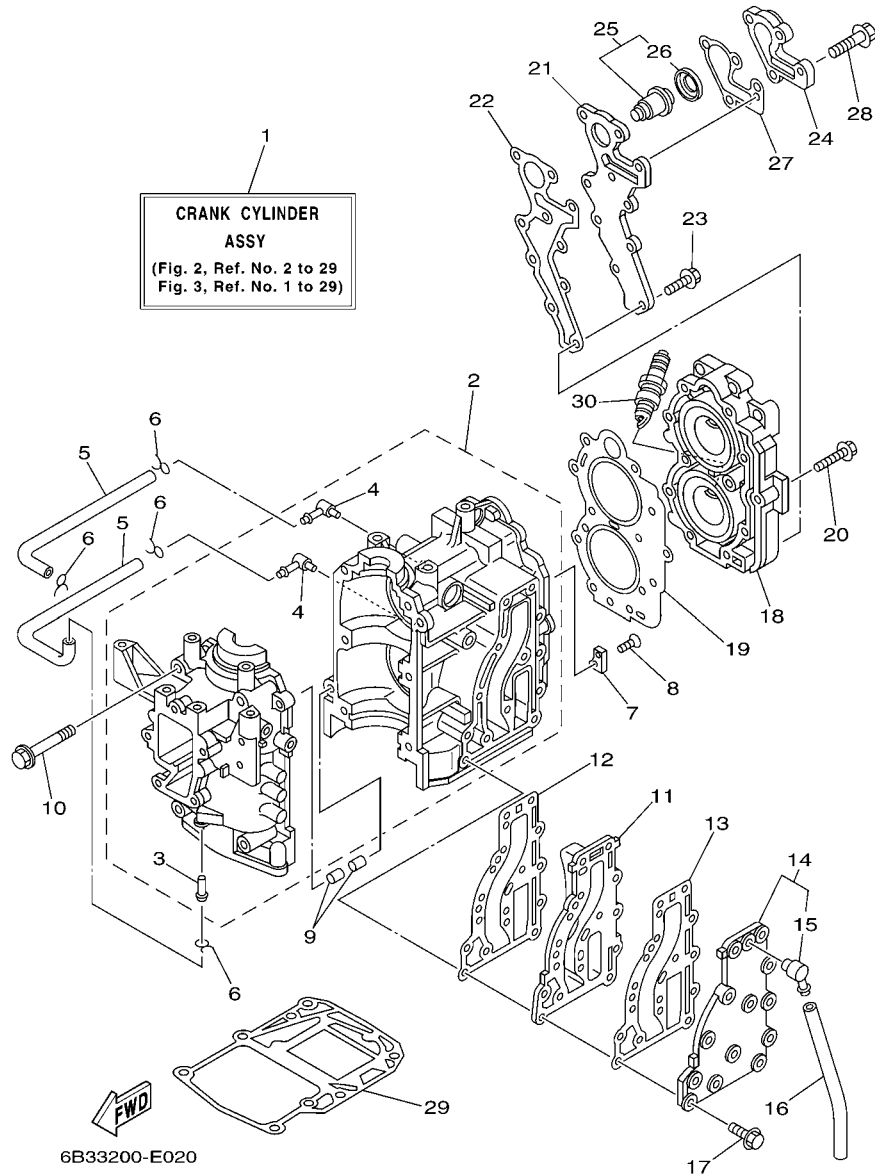

FIG. 2 CYLINDER & CRANKCASE CYLINDRO & CARTER

REF. NO.	PART NO. CODIGO Nº	DESCRIPTION DESCRIPCION	6B39	6B49		REMARKS OBSERVACIONES
1	6B4-W0090-00-1S	CRANK CYLINDER ASSY BLOQUE MOTOR COMPLETO	1	1		
2	6B4-15100-00	CRANKCASE ASSY CARTER COMPLETO	1	1		
3	624-14485-00	.PIPE, JOINT .TUBO DE UNION	1	1		
4	650-14485-03	.PIPE, JOINT .TUBO DE UNION	2	2		
5	90445-07M08	HOSE (L220) TUBO (L220)	2	2		
6	90467-06016	CLIP PRESILLA	4	4		
7	682-11325-00	ANODE ANODO	1	1		
8	98780-05015	SCREW, FLAT HEAD TORNILLO CABEZA PLANA	1	1		
9	93606-12019	PIN, DOWEL PASADOR DE CLAVIJA	2	2		
10	90119-08M07	BOLT, WITH WASHER TORNILLO CON ARANDELA	6	6		
11	63V-41111-00-1S	INNER COVER, EXHAUST CUBIERTA INTERIOR DE ESCAPE	1	1		
12	6B4-41112-A0	GASKET, EXHAUST INNER COVER EMPAQUE	1	1		
13	63V-41112-A0	GASKET, EXHAUST INNER COVER EMPAQUE	1	1		
14	63V-41113-00-1S	OUTER COVER, EXHAUST CUBIERTA EXTERIOR DE ESCAPE	1	1		
15	676-11372-00	.NIPPLE, HOSE .NIPLE DE MANGUERA	1	1		
16	90445-09104	HOSE (L300) TUBO (L300)	1	1		
17	90119-06MA4	BOLT, WITH WASHER TORNILLO CON ARANDELA	13	13		
18	6B4-11111-00-1S	HEAD, CYLINDER 1 CULATA CILINDRO 1	1	1		
19	63V-11181-A2	GASKET, CYLINDER HEAD 1 JUNTA, DE CULATA 1	1	1		
20	90105-07M05	BOLT, FLANGE TORNILLO	11	11		
21	6B4-11191-00-1S	COVER, CYLINDER HEAD 1 TAPA CULATA DE CILINDRO 1	1	1		
22	6B4-11193-A1	GASKET, HEAD COVER 1 EMPAQUE	1	1		
23	90119-06023	BOLT, WITH WASHER TORNILLO CON ARANDELA	6	6		
24	682-12413-00-1S	COVER, THERMOSTAT CUBIERTA TERMOSTATO	1	1		
25	6E5-12411-30	THERMOSTAT TERMOSTAT	1	1		
26	688-12412-00	.SEAL, THERMOSTAT .SELLO TERMOSTATO	1	1		
27	682-12414-A1	GASKET, COVER EMPAQUE	1	1		

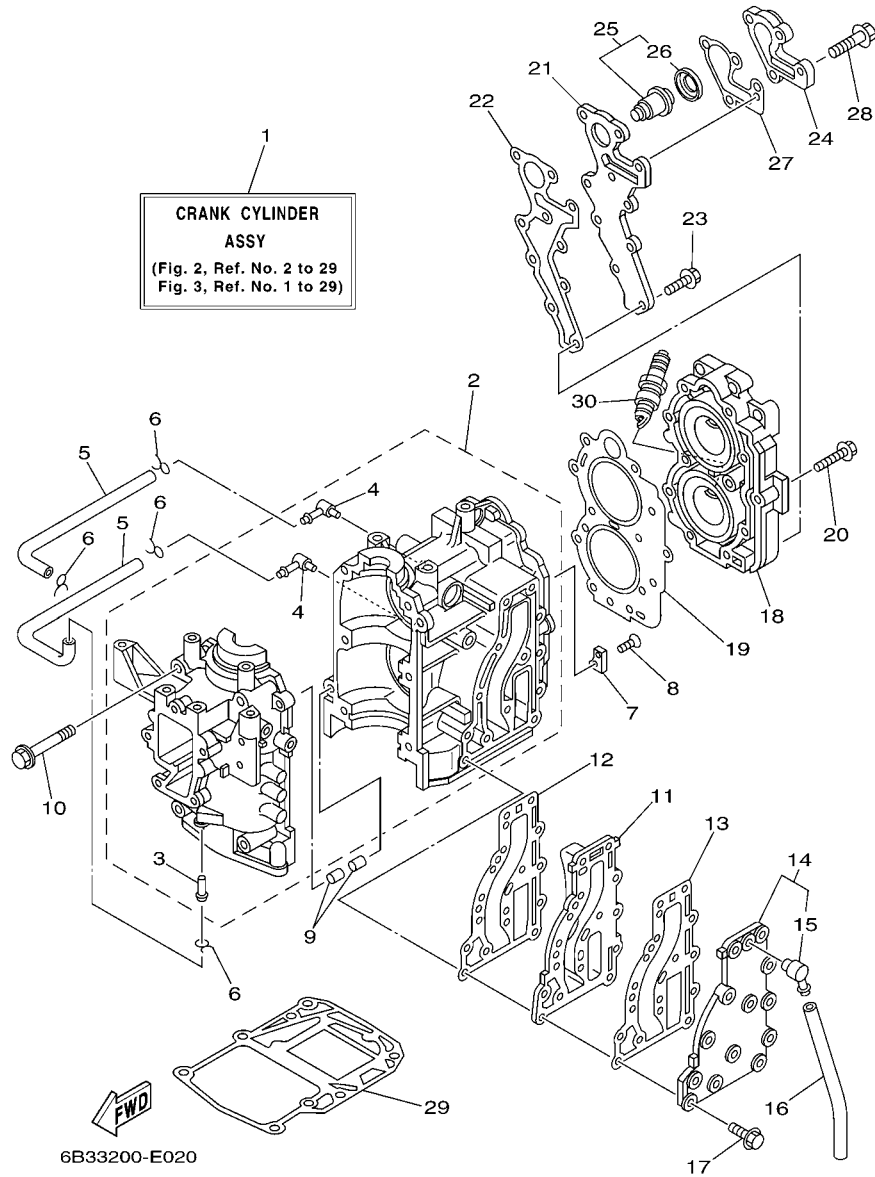
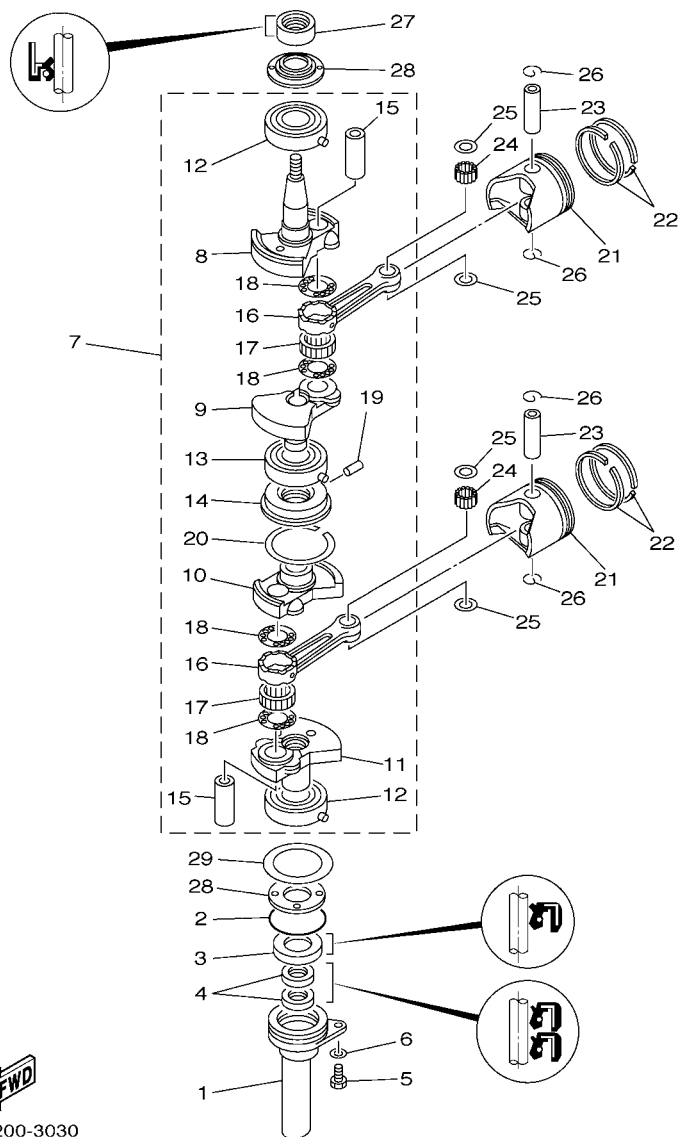

FIG. 2 CYLINDER & CRANKCASE **CYLINDRO & CARTER**

REF. NO.	PART NO. CODIGO Nº	DESCRIPTION DESCRIPCION			REMARKS OBSERVACIONES
			6B39	6B49	
28	90119-06MA3	BOLT, WITH WASHER TORNILLO CON ARANDELA	4	4	
29	6B4-11351-A1	GASKET, CYLINDER JUNTA, DE CILINDRO	1	1	
30	94702-00160	PLUG, SPARK (NGK B8HS-10) BUJIA (NGK B8HS-10)	2	2	
	94702-00247	PLUG, SPARK (NGK BR8HS-10) BUJIA (NGK BR8HS-10)	2	2	FOR CAR FOR CAR

FIG. 3 CRANKSHAFT & PISTON

CIGUENAL & PISTON



6B31200-3030

REF. NO.	PART NO. CODIGO Nº	DESCRIPTION DESCRIPCION	6B39	6B49	REMARKS OBSERVACIONES
1	6B4-15396-00-CA	HOUSING, OIL SEAL CAJA DE SELLO DE ACEITE	1	1	
2	93210-46M16	O-RING ANILLO O	1	1	
3	93102-25010	OIL SEAL SELLO ACEITE	1	1	
4	93101-13M27	OIL SEAL SELLO ACEITE	2	2	
5	97095-06016	BOLT PERNO	1	1	
6	92995-06600	WASHER ARANDELA	1	1	
7	6B4-11400-00	CRANKSHAFT ASSY CIGUENAL COMPLETO	1	1	
8	63V-11412-00	.CRANK 1 .MANIVELA 1	1	1	
9	63V-11422-00	.CRANK 2 .MANIVELA 2	1	1	
10	63V-11432-00	.CRANK 3 .MANIVELA 3	1	1	
11	63V-11442-00	.CRANK 4 .MANIVELA 4	1	1	
12	93306-205A1	.BEARING .COJINETE	2	2	
13	93390-00029	.BEARING .COJINETE DE RODILLOS	1	1	
14	63V-11515-02	.SEAL, LABYRINTH 1 .SELLO LABERINTO 1	1	1	
15	682-11681-00	.PIN, CRANK 1 .PASADOR MANIVELA 1	2	2	
16	6K4-11651-00	.ROD, CONNECTING .BIELA	2	2	
17	93310-620W5	.BEARING .COJINETE DE RODILLOS	2	2	
18	90209-20M23	.WASHER .ARANDELA DE SEPARACION	4	4	
19	91609-20008	.PIN, SPRING .PASADOR DE RESORTE	1	1	
20	93440-52009	.CIRCLIP .SEGURO	1	1	
21	6E7-11631-00-97	PISTON (STD) PISTON (NORMA)	2	2	
	6E7-11635-00	PISTON (0.25MM O/S) PISTON (0.25MM O/S)	2	2	AP AP
	6E7-11636-00	PISTON (0.50MM O/S) PISTON (0.50MM O/S)	2	2	AP AP
22	682-11610-01	PISTON RING SET (STD) JUEGO DE ANILLOS (NORMA)	2	2	
	682-11610-11	PISTON RING SET (0.25MM O/S) JUEGO DE ANILLOS (0.25MM O/S)	2	2	AP AP
	682-11610-21	PISTON RING SET (0.50MM O/S) JUEGO DE ANILLOS (0.50MM O/S)	2	2	AP AP
23	634-11633-00	PIN, PISTON PASADOR, PISTON	2	2	

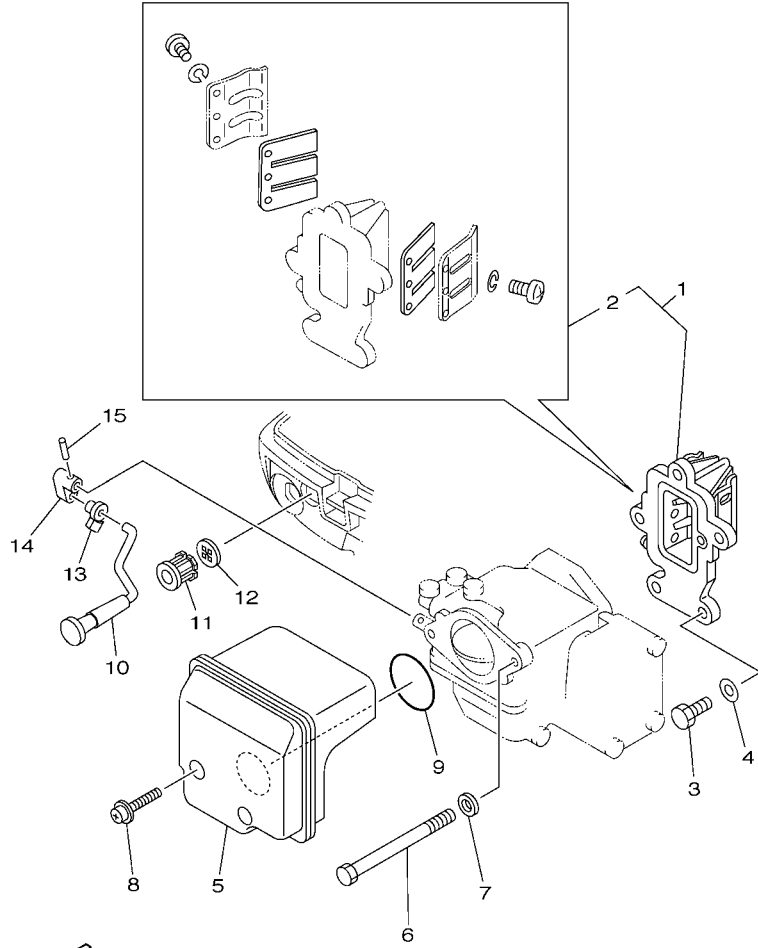

FWD
6B31200-3040

FIG. 4 INTAKE ADMISION

REF. NO.	PART NO. CODIGO Nº	DESCRIPTION DESCRIPCION	6B39	6B49	REMARKS OBSERVACIONES
1	63V-13610-10	REED VALVE ASSY VALVULA DE LAMINAS COMPLETA	1		
	63W-13610-00	REED VALVE ASSY VALVULA DE LAMINAS COMPLETA		1	
2	682-W0004-00	.REED SET .JUEGO DE VALVULAS DE LENGUETA	1	1	
3	97095-06020	BOLT PERNO	3	3	
4	92995-06600	WASHER ARANDELA	3	3	
5	6B4-14440-00	SILENCER ASSY, INTAKE SILENCIADOR COMPL DE ADMISION	1	1	
6	97095-06095	BOLT PERNO	2	2	
7	92995-06600	WASHER ARANDELA	2	2	
8	90159-05007	SCREW, WITH WASHER TORNILLO CON VALONA	2	2	
9	93210-35M86	O-RING ANILLO O	1	1	
10	6B4-41271-01	KNOB, CHOKE PERILLA AHOGADOR	1	1	
11	6B4-41273-00	GROMMET TAPON PROTECTOR	1	1	
12	6B4-41274-00	GROMMET 2 TAPON 2	1	1	
13	6B4-41262-00	JOINT, CHOKE LEVER CONECTOR DE AHOGADOR	1	1	
14	6B4-41252-00	LEVER, CHOKE 1 PALANCA AHOGADOR 1	1	1	
15	91690-20010	PIN, SPRING PASADOR DE RESORTE	1	1	

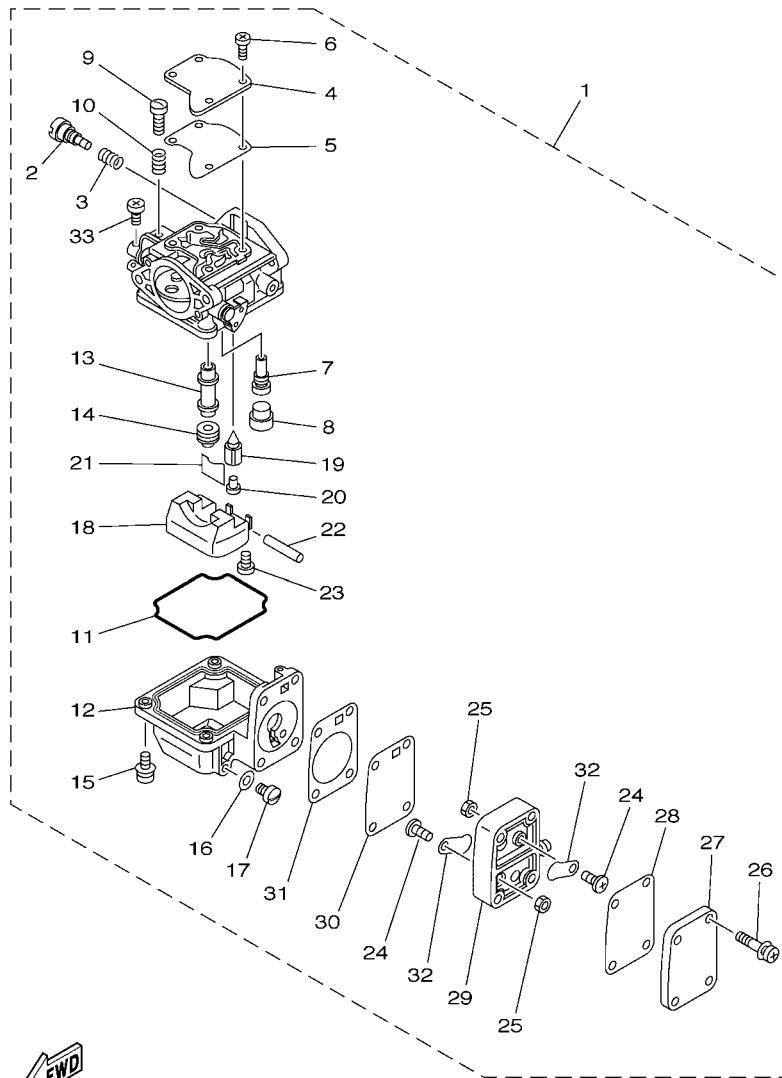

6B31200-3050

FIG. 5 CARBURETOR

CARBURADOR

REF. NO.	PART NO. CODIGO Nº	DESCRIPTION DESCRIPCION	6B39	6B49		REMARKS OBSERVACIONES
1	6B3-14301-00	CARBURETOR ASSY 1 CARBURADOR COMPLETO 1	1			
	6B4-14301-00	CARBURETOR ASSY 1 CARBURADOR COMPLETO 1		1		
2	679-14923-00	.SCREW, PILOT .TORNILLO DE AJUSTE	1	1		
3	679-14555-00	.SPRING .RESORTE	1	1		
4	63V-14527-00	.PLATE .PLACA	1	1		
5	63V-14126-00	.GASKET .EMPAQUE	1	1		
6	97803-04010	.SCREW, PAN HEAD .TORNILLO CABEZA ABULTADA	4	4		
7	63V-14948-06	.JET (#48) .INYECTOR (#48)	1	1		
8	679-14966-00	.RUBBER CAP .CAUCHOCHAPEAU	1	1		
9	63V-14523-00	.SCREW, STOP .TORNILLO DE TOPE	1	1		
10	90501-10326	.SPRING, COMPRESSION .RESORTE DE COMPRESION	1	1		
11	63V-14984-00	.GASKET, FLOAT CHAMBER .EMPAQUE CAMARA DE BOIA	1	1		
12	63V-14980-00	.BODY, FLOAT CHAMBER .CUERPO CAMARA DE BOIA	1	1		
13	6B3-14947-00	.JET, NEEDLE .INYECTOR DE AGUJA	1			
	63V-14947-00	.JET, NEEDLE .INYECTOR DE AGUJA		1		
14	676-14943-29	.JET, MAIN (#110) .INYECTOR PRINCIPAL (#110)	1			
	676-14943-79	.JET, MAIN (#108) .INYECTOR PRINCIPAL (#108)		1		
15	97980-04114	.SCREW, WITH WASHER .TORNILLO, CON ARANDELA	4	4		
16	65W-14398-00	.GASKET .EMPAQUE	1	1		
17	6G1-14992-00	.SCREW, DRAIN .TORNILLO, SEGURO	1	1		
18	63V-14985-00	.FLOAT .BOIA	1	1		
19	6G1-14546-01	.VALVE, NEEDLE .VALVULA DE AGUJA	1	1		
20	676-14186-00	.PIN, FLOAT .PASADOR DE LA BOYA	1	1		
21	663-14159-00	.CLIP .PRESILLA	1	1		
22	6H4-14548-00	.PIN, FLOAT ARM .PASADOR DE BRAZO DE BOIA	1	1		
23	98580-04008	.SCREW, PAN HEAD .TORNILLO DE CABEZA CRUZADA	1	1		
24	98980-03006	.SCREW, BIND .TORNILLO DE LIGAR	2	2		

FIG. 6 FUEL

COMBUSTIBLE

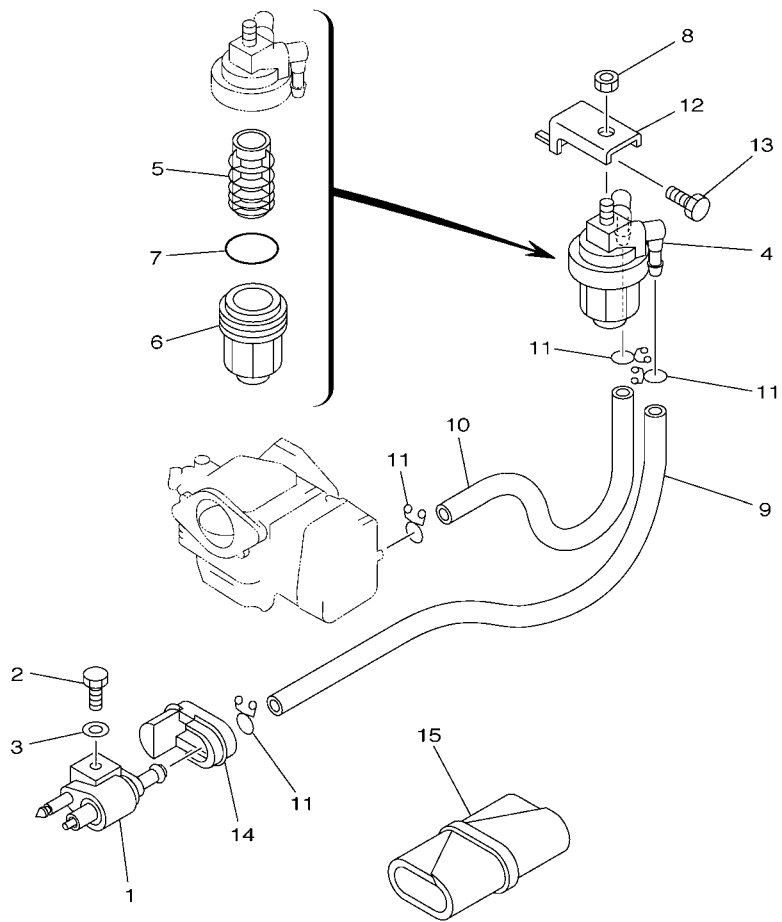

6B31200-3060

REF. NO.	PART NO. CODIGO Nº	DESCRIPTION DESCRIPCION	6B39	6B49	REMARKS OBSERVACIONES
1	6G1-24304-02	FUEL PIPE JOINT COMP. 1 CONECTOR MANGUERA COMBUST.1	1	1	
2	97095-06020	BOLT PERNO	1	1	
3	92995-06600	WASHER ARANDELA	1	1	
4	61N-24560-00	FILTER ASSY FILTRO COMPLETO	1	1	
5	61N-24563-00	.ELEMENT, FILTER .ELEMENTO DEL FILTRO	1	1	
6	61N-24521-00	.CUP, FILTER .COPA DE FILTRO	1	1	
7	93210-32738	.O-RING .ANILLO O	1	1	
8	95380-08600	NUT TUERCA	1	1	
9	90445-09104	HOSE (L300) TUBO (L300)	1	1	
10	90445-09M00	HOSE (L180) TUBO (L180)	1	1	
11	90467-08004	CLIP PRESILLA	4	4	
12	648-24566-02	BRACKET, FILTER SOPORTE DEL FILTRO	1	1	
13	97013-06010	BOLT PERNO	1	1	
14	6B4-24329-00	SEAL SELLO	1	1	
15	656-W2810-02	TOOL KIT JUEGO DE HERRAMIENTAS	1	1	

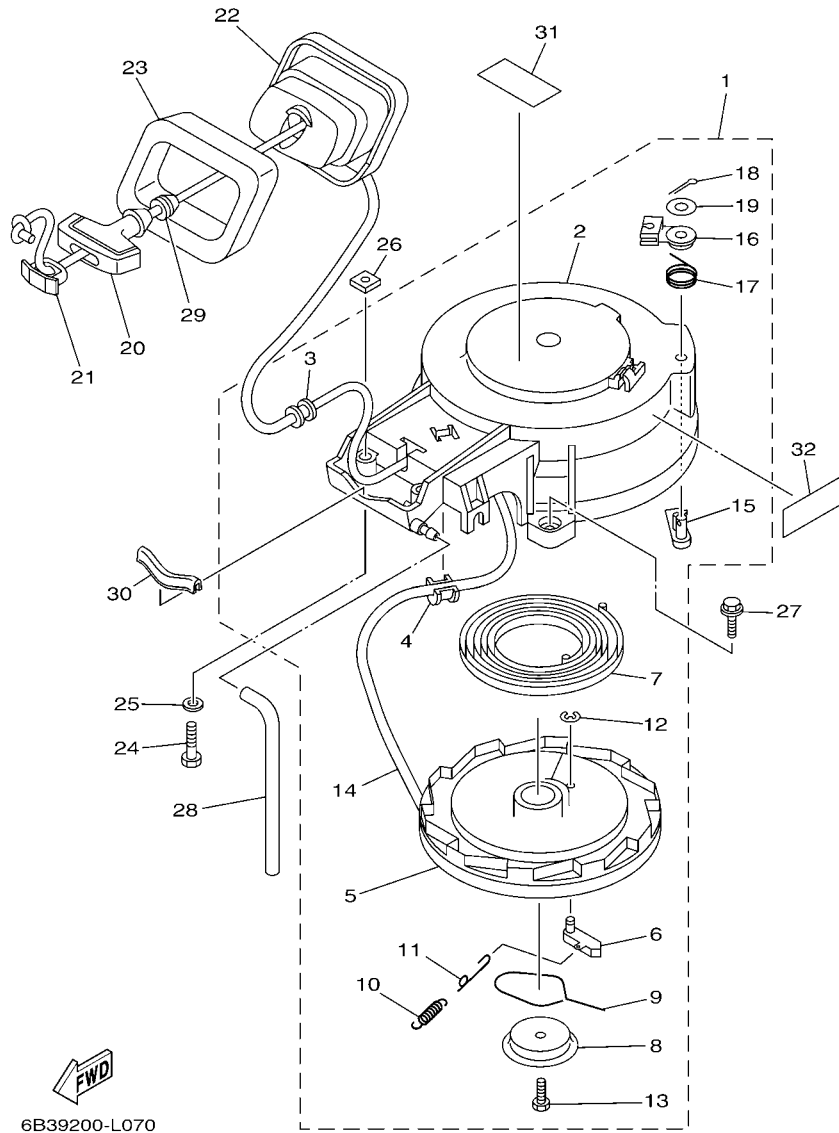

6B39200-L070

*1: CUT FROM 50M ROLLS, PART NO. 90890-44373, CUTTING LENGTH 1.8M

*1: CORTE DE UN RODILLO DE 50M , PARTS NUMERO 90890-44373, LARGO DEL CORTE 1.8M

FIG. 7 STARTER

ARRANQUE

REF. NO.	PART NO. CODIGO Nº	DESCRIPTION DESCRIPCION	6B39	6B49	REMARKS OBSERVACIONES
1	6B4-15710-00	STARTER ASSY ARRANQUE COMPLETO	1	1	
2	6B4-15711-00	.CASE, STARTER .CAJA DE ARRANQUE	1	1	
3	63V-15764-00	.COLLAR 1 .COLLAR 1	1	1	
4	68T-15764-00	.COLLAR 1 .COLLAR 1	1	1	
5	63V-15714-00	.DRUM, SHEAVE .TAMBOR ROLDANA	1	1	
6	63V-15741-00	.PAWL, DRIVE .TRINQUETE DE TRACCION	1	1	
7	63V-15713-00	.SPRING, STARTER .RESORTE DE ARRANQUE	1	1	
8	63V-15716-00	.PLATE, DRIVE .PLACA DE TRACCION	1	1	
9	63V-15705-01	.SPRING, DRIVE PAWL .RESORTE	1	1	
10	63V-15767-01	.SPRING .RESORTE	1	1	
11	68T-15784-00	.SPRING, RETURN .RESORTE DE RETORNO	1	1	
12	63V-15744-00	.CIRCLIP .SEGURO	1	1	
13	63V-15768-00	.BOLT .TORNILLO	1	1	
14	*	.WIRE, STARTER (L:1800MM) .CUERDA DE ARRANQUE (L:1800MM)	1	1	*1 *1
15	63V-15794-00	.STOPPER .TOPE	1	1	
16	63V-15748-00	.PLUNGER, STARTER STOP .EMBOLO SEGURO DE ARRANQUE	1	1	
17	63V-15734-00	.SPRING, RETURN .RESORTE DE RETORNO	1	1	
18	91490-16018	.PIN, COTTER .CHAVETA	1	1	
19	63V-15726-00	.WASHER, FLAT .ARANDELA PLANA	1	1	
20	6G1-15755-00	HANDLE, STARTER MANIJA DE ARRANQUE	1	1	
21	6G1-15779-00	COVER CUBIERTA	1	1	
22	6B4-15758-10	GUIDE, ROPE GUIA DE CUERDA	1	1	
23	6B4-15762-00	SEAL, RUBBER 2 SELLO DE GOMA 2	1	1	
24	97095-06035	BOLT PERNO	2	2	
25	92995-06600	WASHER ARANDELA	2	2	
26	90173-06009	NUT, SQUARE TUERCA CUADRADA	2	2	
27	90119-06M82	BOLT, WITH WASHER TORNILLO CON ARANDELA	3	3	

FIG. 8 GENERATOR

GENERADOR

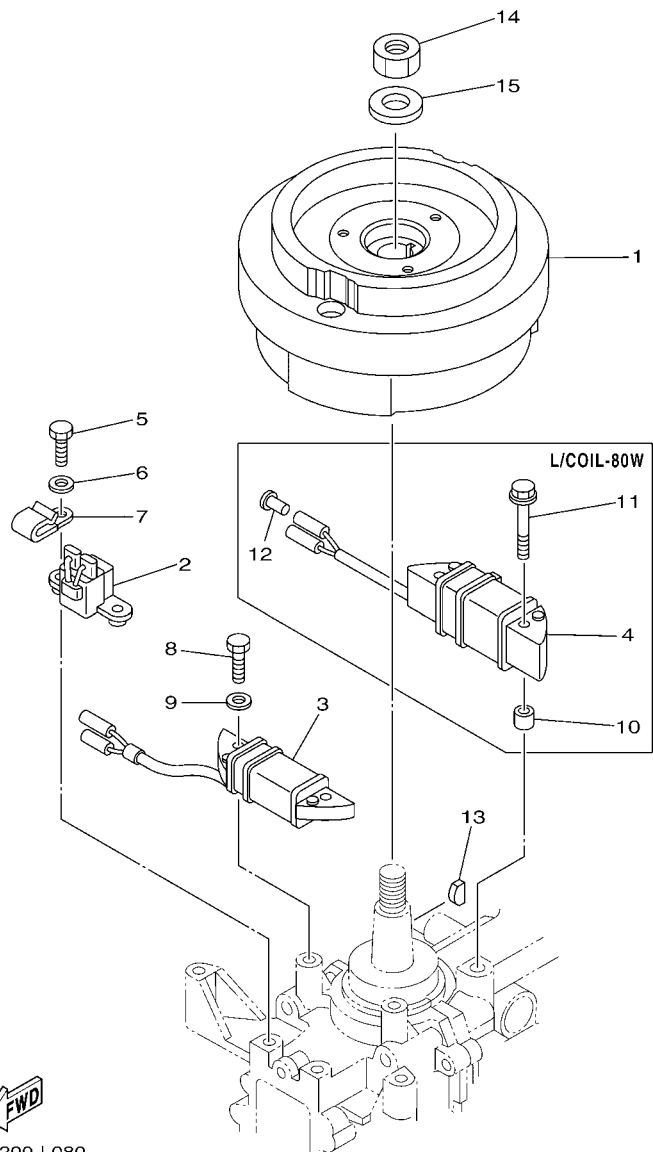

6B39200-L080

REF. NO.	PART NO. CODIGO Nº	DESCRIPTION DESCRIPCION	6B39	6B49	REMARKS OBSERVACIONES
1	6B4-85550-01	ROTOR ASSY ROTOR COMPLETO	1	1	UR FOR STD UR FOR STD
	6B4-85550-10	ROTOR ASSY ROTOR COMPLETO	1	1	UR UR
2	6B4-85580-00	COIL, PULSER BOBINA DE PULSACION	1	1	
3	6B4-85520-00	COIL, CHARGE BOBINA DE CARGA	1	1	
4	63V-85533-00	COIL, LIGHTING BOBINA DE LUZ		1	WITH L/COIL-80W WITH L/COIL-80W
5	97095-06016	BOLT PERNO	2	2	
6	92995-06600	WASHER ARANDELA	2	2	
7	90465-06M90	CLAMP BRIDA	1	1	
8	97095-06020	BOLT PERNO	2	2	
9	92995-06600	WASHER ARANDELA	2	2	
10	90387-06M24	COLLAR ESPACIADOR		2	WITH L/COIL-80W WITH L/COIL-80W
11	90119-06M40	BOLT, WITH WASHER TORNILLO CON ARANDELA		2	WITH L/COIL-80W WITH L/COIL-80W
12	703-82119-00	COVER, LEAD WIRE CUBIERTA DE CABLE CONDUCTOR		2	WITH L/COIL-80W WITH L/COIL-80W
13	90280-05013	KEY, WOODRUFF CUNA WOODRUFF	1	1	
14	90170-12066	NUT TUERCA	1	1	
15	90201-12472	WASHER, PLATE ARANDELA PLANA	1	1	

FIG. 9 ELECTRICAL

ELECTRICO

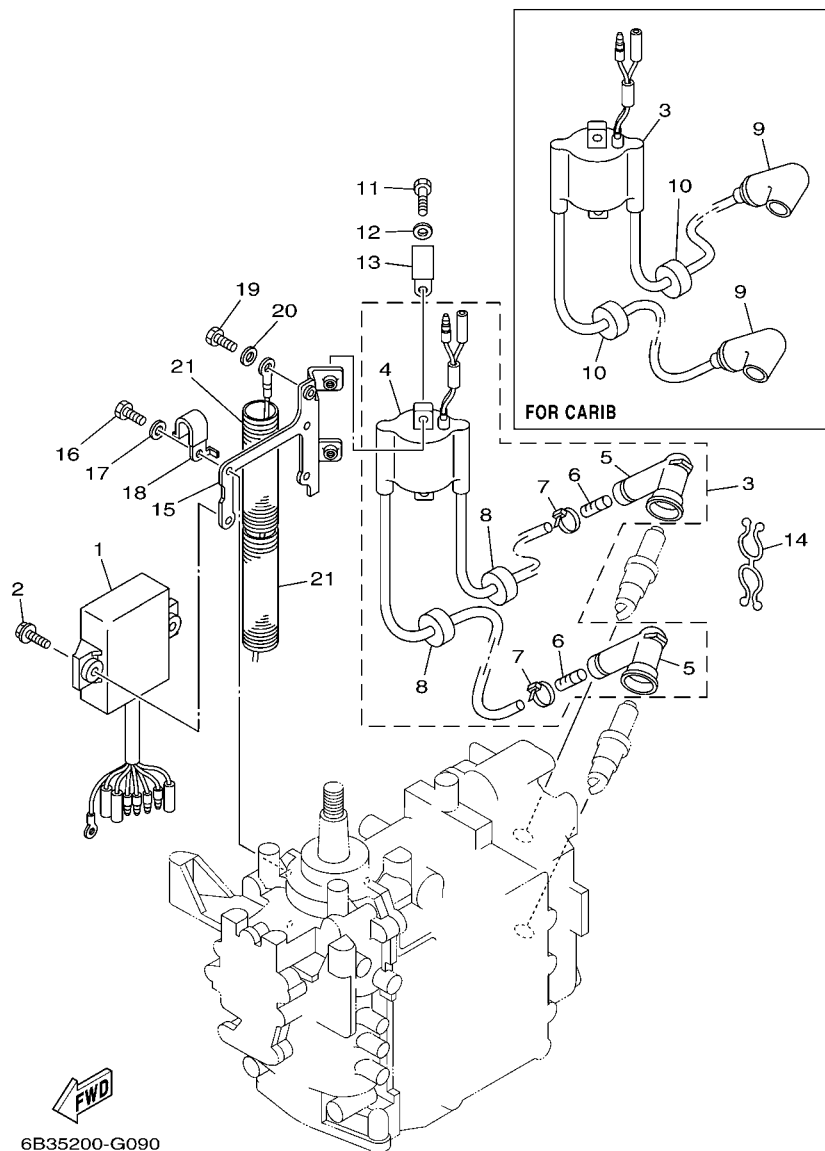

6B35200-G090

REF. NO.	PART NO. CODIGO Nº	DESCRIPTION DESCRIPCION	6B39	6B49	REMARKS OBSERVACIONES
1	6B4-85540-03	C.D.I. UNIT ASSY UNIDAD C.D.I. COMPLETA	1	1	
2	90119-06M83	BOLT, WITH WASHER TORNILLO CON ARANDELA	2	2	
3	6B4-85530-00	IGNITION COIL ASSY BOBINA DE IGNICION COMPLETO	1	1	
	6B4-85570-00	IGNITION COIL ASSY BOBINA DE IGNICION COMPLETO	1	1	FOR CAR FOR CAR
4	6B4-85570-00	.IGNITION COIL ASSY .BOBINA DE IGNICION COMPLETO	1	1	FOR 6B4-85530-00 FOR 6B4-85530-00
5	62E-82371-11	.CAP, PLUG .TAPON DE BUJIA COMPLT	2	2	FOR 6B4-85530-00 FOR 6B4-85530-00
6	62E-8231X-00	.TERMINAL 1 .TERMINAL 1	2	2	FOR 6B4-85530-00 FOR 6B4-85530-00
7	90465-11M10	.CLAMP .BRIDA	2	2	FOR 6B4-85530-00 FOR 6B4-85530-00
8	90480-25161	.GROMMET .TAPON	2	2	FOR 6B4-85530-00 FOR 6B4-85530-00
9	6E3-82370-21	PLUG CAP ASSY TAPON DE BUJIA COMPLT	2	2	FOR CAR FOR CAR
10	90480-25161	GROMMET TAPON	2	2	FOR CAR FOR CAR
11	97095-06016	BOLT PERNO	2	2	
12	92995-06600	WASHER ARANDELA	2	2	
13	90465-06M90	CLAMP BRIDA	1	1	
14	90464-08M02	CLAMP BRIDA	1	1	
15	6B4-82316-00	BRACKET, IGNITION COIL SOPORTE BOBINA ENCENDIDO	1	1	
16	97095-06014	BOLT PERNO	2	2	
17	92995-06600	WASHER ARANDELA	2	2	
18	90465-08M99	CLAMP BRIDA	1	1	
19	97095-06010	BOLT PERNO	1	1	
20	92995-06600	WASHER ARANDELA	1	1	
21	6N7-83557-00	TUBE (I.DIA:22MM) ENCHUFE DE ACEITE (I.DIA:22MM)	2	2	

FIG. 10 BOTTOM COWLING

CUBIERTA INFERIOR

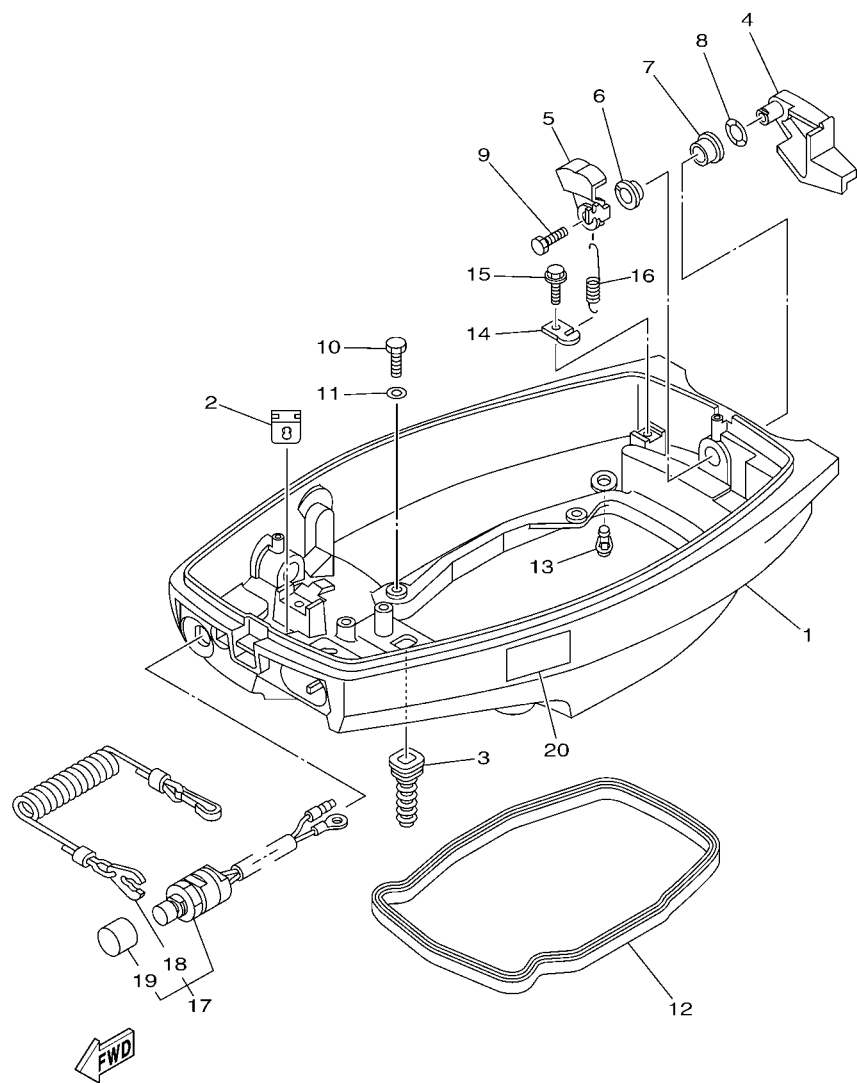

6B89200-L110

REF. NO.	PART NO. CODIGO Nº	DESCRIPTION DESCRIPCION	6B39	6B49		REMARKS OBSERVACIONES
1	6B4-42711-00-4D	COWLING, BOTTOM 1 CUBIERTA INFERIOR 1	1	1		
2	61N-26326-00	GROMMET TAPON PROTECTOR	1	1		
3	6B4-42727-00	GROMMET TAPON	1	1		
4	6B4-42815-00-4D	LEVER, CLAMP PALANCA ABRAZADERA	1	1		
5	6B4-42816-00	LEVER, CLAMP PALANCA ABRAZADERA	1	1		
6	90386-12M45	BUSH BUJE	1	1		
7	90386-12MA2	BUSH BUJE	1	1		
8	90206-12052	WASHER, WAVE ARANDELA ONDULADA	1	1		
9	97095-06014	BOLT PERNO	1	1		
10	97095-06016	BOLT PERNO	4	4		
11	92995-06600	WASHER ARANDELA	4	4		
12	6B4-42716-00	RUBBER, SEAL 1 SELLO DE GOMA 1	1	1		
13	6BL-44391-00	NIPPLE, HOSE NIPLE MANGUERA	1	1		
14	66T-43144-00	HOOK, SPRING GANCHO	1	1		
15	90109-06M80	BOLT PERNO	1	1		
16	90506-18009	SPRING, TENSION RESORTE DE TENSION	1	1		
17	689-82575-04	ENGINE STOP SWITCH ASSY INTERRUPTOR DE PARADA COMPL	1	1		
18	682-82556-00	.LANYARD, STOP SWITCH .CORDON DE INTERRUPTOR PARADA	1	1		
19	689-8257Y-00	.CAP .TAPA	1	1		
20	6AH-42794-40	LABEL, WARNING (GENERAL) ETIQUETA DE PRECAUCION	1	1		

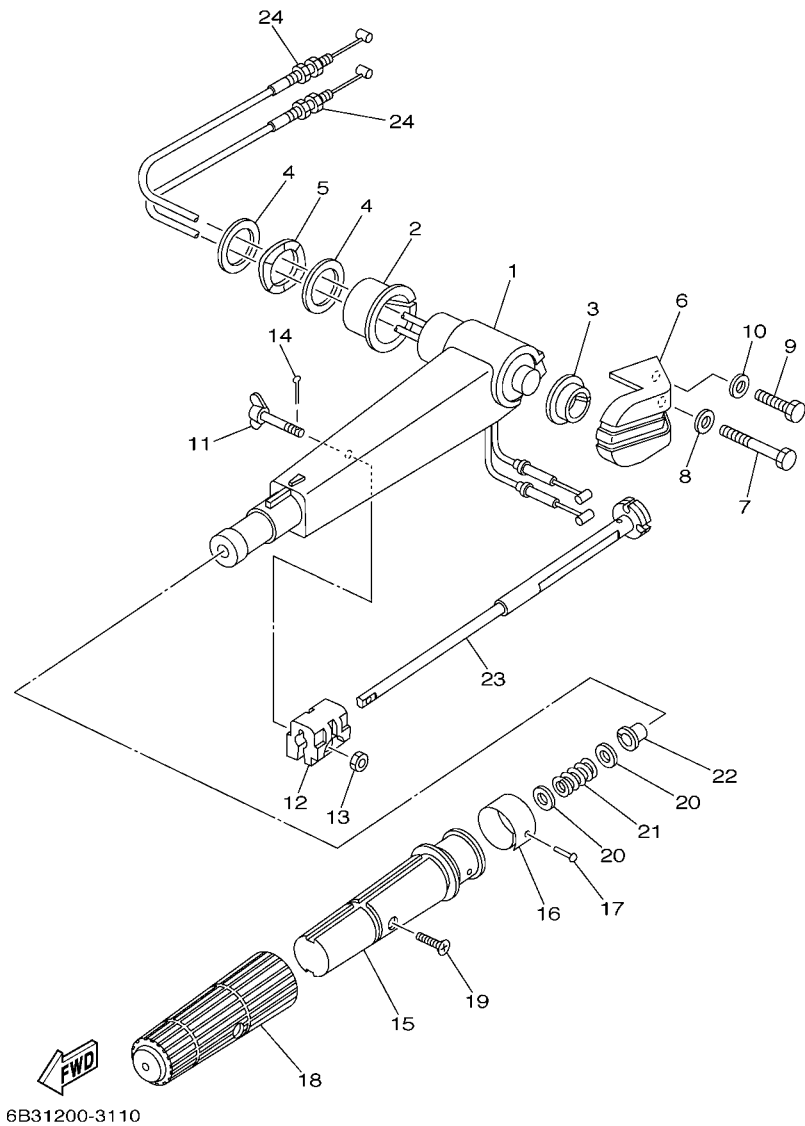
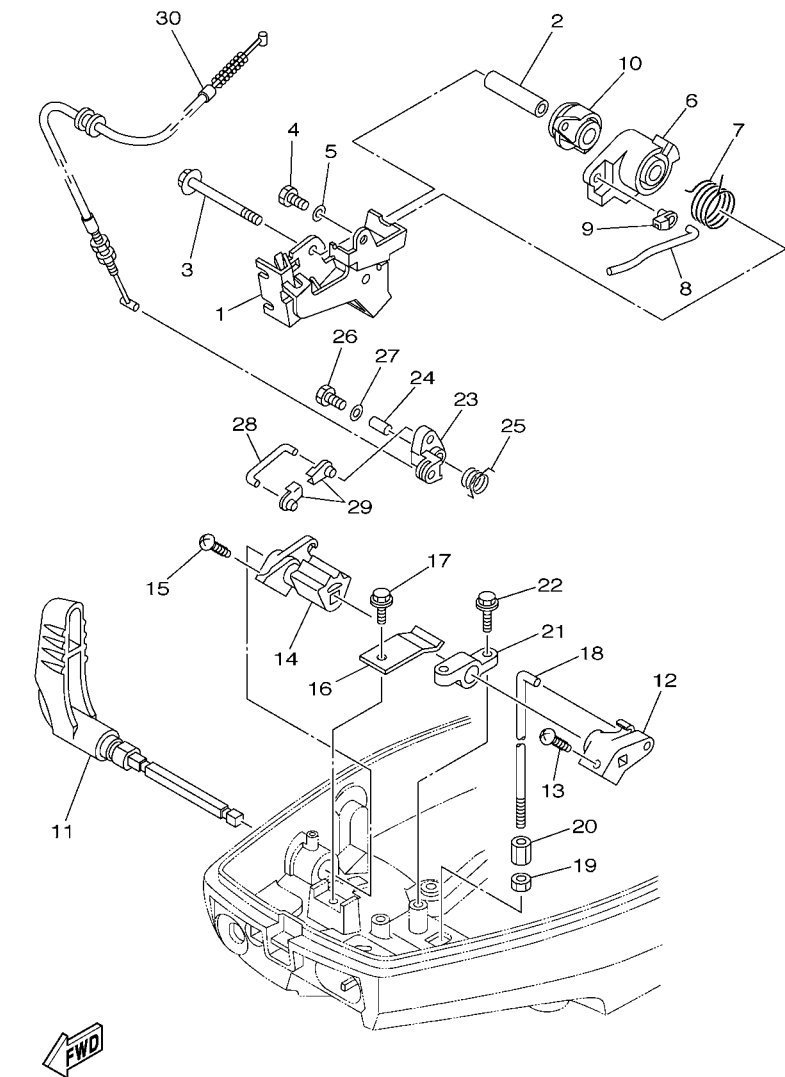

FIG. 11 STEERING

DIRECCION

REF. NO.	PART NO. CODIGO Nº	DESCRIPTION DESCRIPCION	6B39	6B49	REMARKS OBSERVACIONES
1	6B4-42111-00-4D	HANDLE, STEERING MANIJA DE DIRECCION	1	1	
2	90381-35001	BUSH, SOLID BUJE SOLIDO	1	1	
3	90381-20001	BUSH, SOLID BUJE SOLIDO	1	1	
4	90201-28013	WASHER, PLATE ARANDELA PLANA	2	2	
5	90206-28001	WASHER, WAVE ARANDELA ONDULADA	1	1	
6	6B4-42131-00-4D	COVER, HANDLE STEERING CUBIERTA MANIJA DIRRECCION	1	1	
7	97095-08055	BOLT PERNO	1	1	
8	92995-08600	WASHER ARANDELA	1	1	
9	97095-08030	BOLT PERNO	1	1	
10	92995-08600	WASHER ARANDELA	1	1	
11	6B4-42125-00	BOLT, FRICTION ADJUSTING TORNILLO FRICCION ADJUSTA	1	1	
12	6B4-42126-00	FRICTION, STEERING HANDLE GRIP FRICCION DE MANGO DIRECCION	1	1	
13	95380-06600	NUT, HEXAGON TUERCA	1	1	
14	91490-16010	PIN, COTTER CHAVETA	1	1	
15	6B4-42119-00	GRIP, STEERING HANDLE MANGO, MANIJA DE DIRRECCION	1	1	
16	6F5-42137-00	INDICATOR, THROTTLE INDICADOR ACELERADOR	1	1	
17	90269-02M09	RIVET REMACHE	1	1	
18	6G1-42177-00	RUBBER, HANDLE HULE DE MANIJA	1	1	
19	90152-05011	SCREW, COUNTERSUNK TORNILLO EMBUTIDO	1	1	
20	90201-10M02	WASHER, PLATE ARANDELA PLANA	2	2	
21	90501-23215	SPRING, COMPRESSION RESORTE DE COMPRESION	1	1	
22	90386-08032	BUSH BUJE	1	1	
23	6B4-42138-00	LEVER, THROTTLE PLANCA DE ACELERACION	1	1	
24	6B4-26301-00	THROTTLE CABLE ASSY CABLE DE ACELERADOR COMPLETO	2	2	



6B31200-3120

FIG. 12 CONTROL

CONTROL

REF. NO.	PART NO. CODIGO Nº	DESCRIPTION DESCRIPCION	6B39	6B49	REMARKS OBSERVACIONES
1	63V-14497-02	STAY, THROTTLE WIRE SOPORTE VALVULA DE OBTURACION	1	1	
2	90387-06M50	COLLAR ESPACIADOR	1	1	
3	95895-06065	BOLT, FLANGE TORNILLO DE REBORDE	1	1	
4	97095-06012	BOLT PERNO	1	1	
5	92995-06600	WASHER ARANDELA	1	1	
6	6B4-41283-00	LEVER, FREE ACCEL. PALANCA	1	1	
7	90508-20M38	SPRING, TORSION RESORTE DE TORSION	1	1	
8	63V-41211-00	LINK, ACCEL. ESLABON, ACELERADOR	1	1	
9	6J8-41262-00	JOINT, CHOKE LEVER CONECTOR DE AHOGADOR	1	1	
10	6B4-41638-00	PULLEY POLEA	1	1	
11	6B4-44111-00-4D	HANDLE, GEAR SHIFT MANIJA DE CAMBIO DE MARCHAS	1	1	
12	6B4-44121-00	LEVER, SHIFT ROD PALANCA VARILLA CAMBIOS	1	1	
13	97780-40520	SCREW, TAPPING TORNILLO DE CABEZA DE CONO ACH	1	1	
14	6B4-44125-00	LEVER, SHIFT ROD PALANCA VARILLA CAMBIOS	1	1	
15	97780-40520	SCREW, TAPPING TORNILLO DE CABEZA DE CONO ACH	1	1	
16	6B4-44116-00	SPRING RESORTE	1	1	
17	90109-06M80	BOLT PERNO	1	1	
18	6B4-44143-00	ROD, SHIFT VARILLA DE CAMBIO	1	1	
19	95380-06700	NUT TUERCA	1	1	
20	61N-44146-00	CONNECTOR, SHIFT ROD CONECTOR VARILLA DE CAMBIO	1	1	
21	6B4-41662-00	BRACKET 2 SOPORTE 2	1	1	
22	90109-06M81	BOLT PERNO	2	2	
23	6B4-15746-00	ARM BRAZO	1	1	
24	90387-06M06	COLLAR ESPACIADOR	1	1	
25	90508-08M39	SPRING, TORSION RESORTE DE TORSION	1	1	
26	97095-06020	BOLT PERNO	1	1	
27	92995-06600	WASHER ARANDELA	1	1	

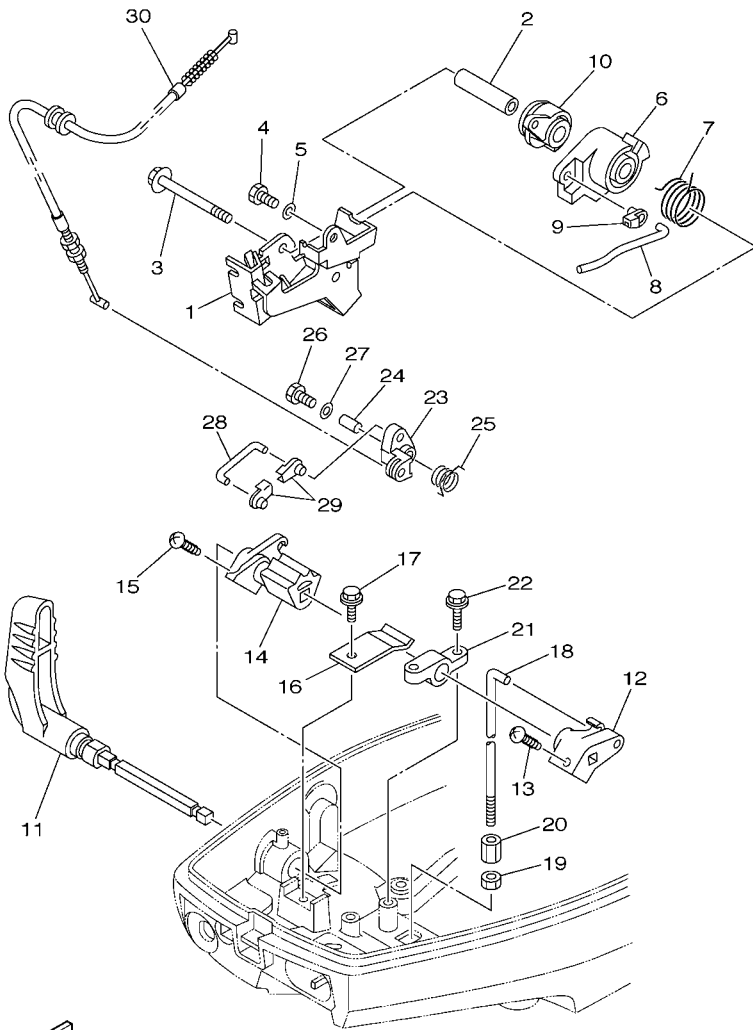

 6B31200-3120

FIG. 12 CONTROL

CONTROL

REF. NO.	PART NO. CODIGO Nº	DESCRIPTION DESCRIPCION	6B39	6B49		REMARKS OBSERVACIONES
28	6L2-15747-00	LINK ESLABON	1	1		
29	6J8-41262-00	JOINT, CHOKE LEVER CONECTOR DE AHOGADOR	2	2		
30	6B4-15770-00	CABLE COMP., STARTER STOP CABLECOMPL DE SEGURO ARRANQUE	1	1		



6B31200-3130

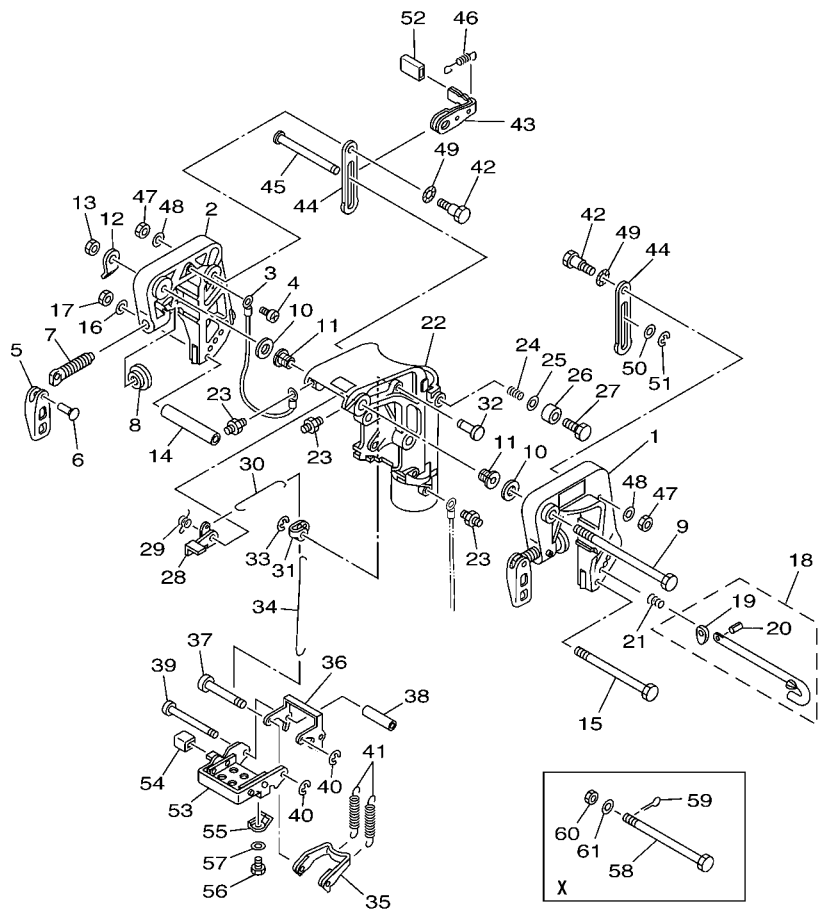

FIG. 13 BRACKET 1

SOPORTE 1

REF. NO.	PART NO. CODIGO Nº	DESCRIPTION DESCRIPCION	6B39	6B49	REMARKS OBSERVACIONES
1	682-43111-05-4D	BRACKET, CLAMP 1 SOPORTE DE LA ABRAZADERA 1	1	1	
2	682-43112-05-4D	BRACKET, CLAMP 2 SOPORTE DE LA ABRAZADERA 2	1	1	
3	6E5-82148-00	WIRE, LEAD 4 CABLE CONDUCTOR 4	1	1	
4	97885-06008	SCREW, PAN HEAD TORNILLO A MUESCA	1	1	
5	663-43118-01-4D	HANDLE, TRANSOM CLAMP MANIJA DE LA ABRAZADERA DEL ES	2	2	
6	90243-04007	PIN PASADOR	2	2	
7	6E7-43116-00	SCREW, TRANSOM CLAMP TORNILLO DE ABRAZADERA	2	2	
8	648-43114-01	PAD, TRANSOM CLAMP ARANDELA DE ABRAZADERA	2	2	
9	90101-12013	BOLT TORNILLO	1	1	
10	90201-12018	WASHER, PLATE ARANDELA PLANA	2	2	
11	90381-12001	BUSH, SOLID BUJE SOLIDO	2	2	
12	6B4-43113-00	PLATE, CLAMP BRACKET PLACA ABRAZADERA SOPORTE	1	1	
13	95780-12300	NUT, FLANGE TUERCA	1	1	
14	90387-06M13	COLLAR ESPACIADOR	1	1	
15	90101-06M29	BOLT TORNILLO	1	1	
16	92990-06600	WASHER, PLATE ARANDELA PLANA	1	1	
17	95380-06700	NUT TUERCA	1	1	
18	689-43160-00	TILT ROD ASSY VARILLA DE BASCULACION COMPL.	1	1	S(17.4"),L(22.4")
19	689-43165-00	.PLATE, TILT LOCK .PLACA DE TOPE, VARILLA SEGURID	1	1	S(17.4"),L(22.4")
20	91690-30008	.PIN, SPRING .PASADOR DE RESORTE	1	1	
21	90502-10M07	SPRING, CONICAL RESORTE CONICO	1	1	S(17.4"),L(22.4")
22	682-43311-07-4D	BRACKET, SWIVEL 1 SOPORTE GIRATORIO 1	1	1	
23	93700-06M03	NIPPLE, GREASE BOQUILLA DE ENGRASAR	3	3	
24	90501-18M00	SPRING, COMPRESSION RESORTE DE COMPRESION	1	1	
25	92990-08600	WASHER, PLATE ARANDELA PLANA	1	1	
26	676-43373-00	SEAL, DAMPER SELLO DE GOMA	1	1	
27	97075-08025	BOLT PERNO	1	1	



6B31200-3130

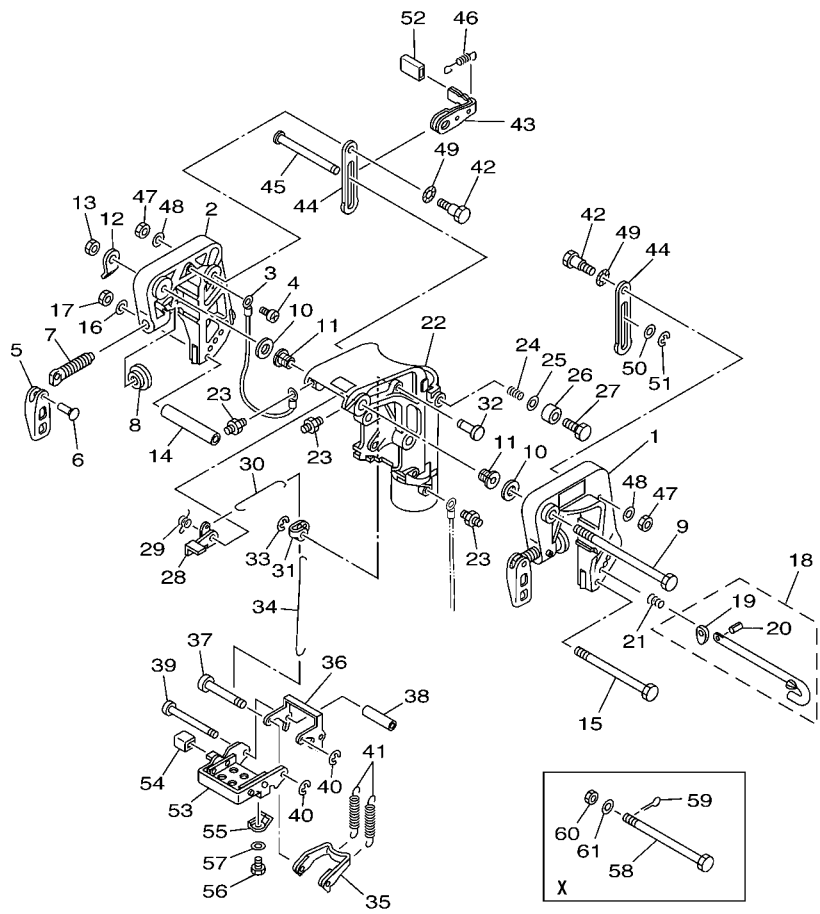

FIG. 13 BRACKET 1

SOPORTE 1

REF. NO.	PART NO. CODIGO Nº	DESCRIPTION DESCRIPCION	6B39	6B49		REMARKS OBSERVACIONES
28	6B4-43631-00	LEVER, TILT PALANCA DE INCLINACION	1	1		
29	90508-14018	SPRING, TORSION RESORTE DE TORSION	1	1		
30	682-43616-00	ROD, TILT LOCK VARILLA SEGURO DE INCLINACION	1	1		
31	682-43641-01	LEVER, TILT PALANCA DE INCLINACION	1	1		
32	90249-06M23	PIN PASADOR	1	1		
33	99080-05600	CIRCLIP PRESILLA REDONDA	1	1		
34	682-43617-00	ROD, TILT LOCK VARILLA SEGURO DE INCLINACION	1	1		
35	682-43614-01	PLATE, TILT LOCK PLACA DE SEGURO DE INCLINACION	1	1		
36	682-43615-02	PLATE, TILT LOCK PLACA DE SEGURO DE INCLINACION	1	1		
37	682-43611-01	SHAFT, TILT LOCK EJE SEGURO INCLINACION	1	1		
38	90387-06M20	COLLAR ESPACIADOR	1	1		
39	682-43659-01	SHAFT, REVERSE LOCK EJE SEGURO DE REVERSA	1	1		
40	99080-05600	CIRCLIP PRESILLA REDONDA	2	2		
41	90506-26M01	SPRING, TENSION RESORTE DE TENSION	2	2		S(17.4"),L(22.4")
	90506-26M07	SPRING, TENSION RESORTE DE TENSION	2	2		X(28.0")
42	90109-06M05	BOLT PERNO	2	2		X(28.0")
43	6B4-43181-00	LEVER, TILT STOP 1 PALANCA TOPE INCLINACION 1	1	1		
44	6B4-43627-00	STOPPER RETEN	2	2		
45	90249-10003	PIN PASADOR	1	1		
46	90506-12002	SPRING, TENSION RESORTE DE TENSION	1	1		
47	95680-06100	NUT, U TUERCA U	2	2		
48	92990-06600	WASHER, PLATE ARANDELA PLANA	2	2		
49	90206-10M24	WASHER, WAVE ARANDELA ONDULADA	2	2		
50	90202-10M56	WASHER, PLATE ARANDELA DE PLANA	1	1		
51	99080-09600	CIRCLIP PRESILLA REDONDA	1	1		
52	682-43318-01	COVER CUBIERTA	1	1		
53	6B4-43681-00	LEVER, SHALLOW WATER DRIVE 1 PALANCA 1	1	1		

FIG. 13 BRACKET 1

SOPORTE 1

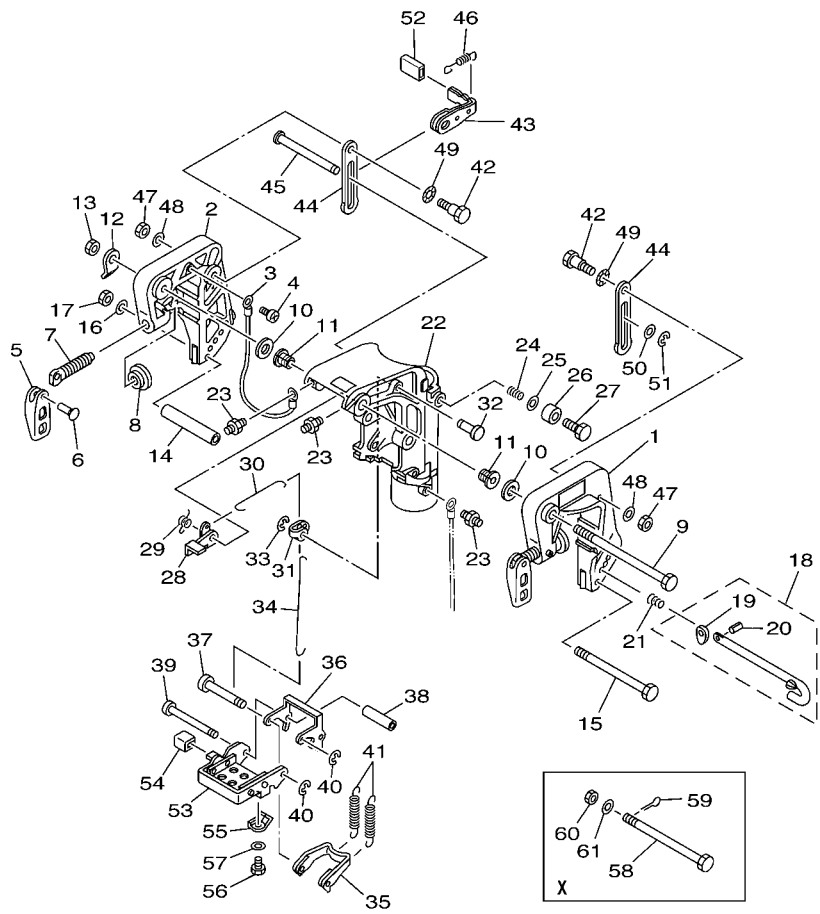

REF. NO.	PART NO. CODIGO Nº	DESCRIPTION DESCRIPCION	6B39	6B49	REMARKS OBSERVACIONES
54	682-43318-01	COVER CUBIERTA	1	1	
55	682-43643-00	SPRING RESORTE	1	1	
56	97095-06008	BOLT PERNO	1	1	
57	92990-06600	WASHER, PLATE ARANDELA PLANA	1	1	
58	90102-08M01	BOLT, WITH HOLE PERNO CON ORIFICIO		1	X(28.0") X(28.0")
59	91490-20015	PIN. COTTER CHAVETA		1	X(28.0") X(28.0")
60	90171-08M00	NUT, CASTLE TUERCA ENTALLADA		1	X(28.0") X(28.0")
61	92990-08600	WASHER, PLATE ARANDELA PLANA		1	X(28.0") X(28.0")



6B31200-3130

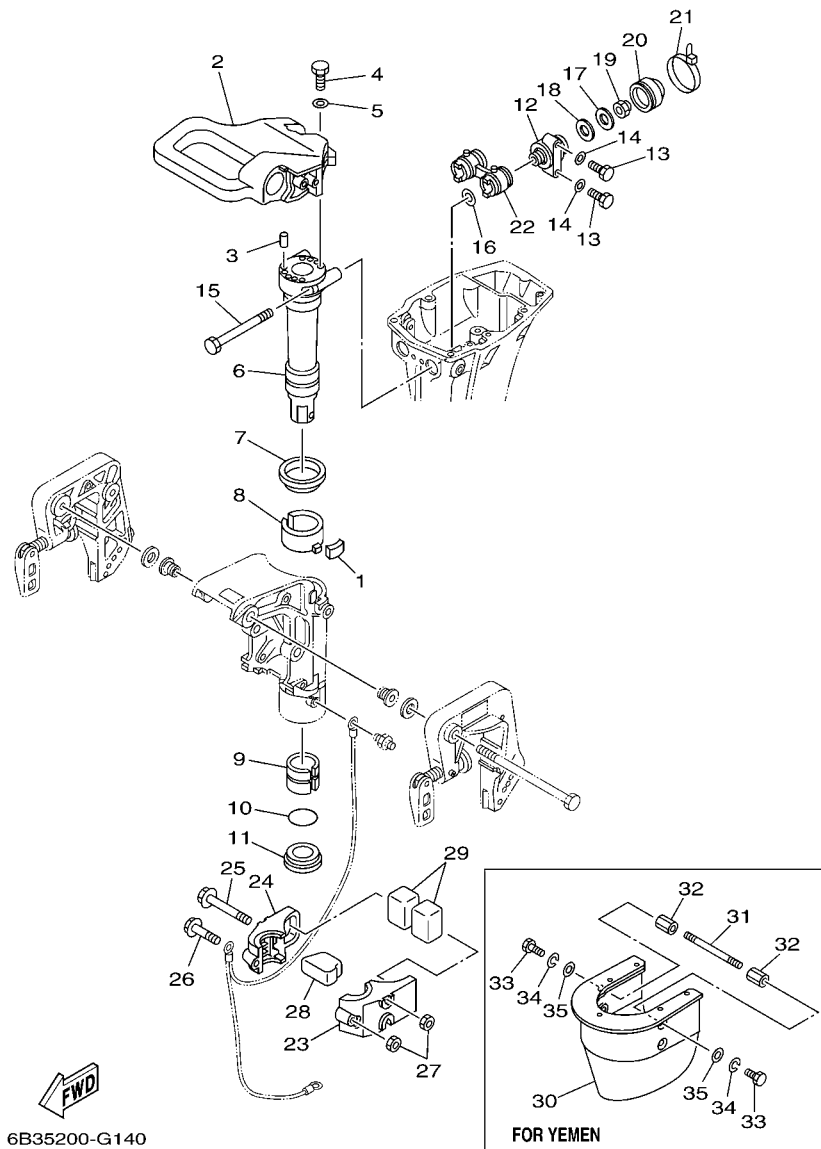

6B35200-G140

FIG. 14 BRACKET 2

SOPORTE 2

REF. NO.	PART NO. CODIGO Nº	DESCRIPTION DESCRIPCION	6B39	6B49	REMARKS OBSERVACIONES
1	648-42528-00	PLATE, FRICTION PIEZA DE FRICCION	1	1	
2	6B4-42511-00-4D	BRACKET, STEERING SOPORTE DE DIRECCION	1	1	
3	93606-12019	PIN, DOWEL PASADOR DE CLAVIJA	2	2	
4	97095-06025	BOLT PERNO	3	3	
5	92995-06600	WASHER ARANDELA	3	3	
6	682-42521-00-94	SHAFT, STEERING PIVOT EJE PIVOTE DE DIRECCION	1	1	
7	90209-52M01	WASHER ARANDELA DE SEPARACION	1	1	
8	682-42537-00	BUSHING, PIVOT SHAFT BUJE DEL PIVOTE DE LA FLECHA	1	1	
9	90386-40M09	BUSH BUJE	1	1	
10	93210-40M10	O-RING ANILLO O	1	1	
11	90386-40M08	BUSH BUJE	1	1	
12	682-44514-01-94 682-44514-31-94	MOUNT DAMPER, UPPER SIDE AMORTIGUADOR LADO SUPERIOR	2	2	S(17.4"),L(22.4") S(17.4"),L(22.4")
13	97095-06025	BOLT PERNO	4	4	X(28.0") X(28.0")
14	92995-06600	WASHER ARANDELA	4	4	
15	90101-08M30	BOLT TORNILLO	2	2	
16	90201-08M12	WASHER, PLATE ARANDELA PLANA	2	2	
17	90201-08M13	WASHER, PLATE ARANDELA PLANA	2	2	
18	90202-13M02	WASHER, PLATE ARANDELA DE PLANA	2	2	
19	90185-08057	NUT, SELF-LOCKING TUERCA AUTOBLOCANTE	2	2	
20	682-44522-01	SEAL SELLO DE GOMA	2	2	
21	90465-11M52	CLAMP BRIDA	2	2	
22	682-44521-01	SEAL SELLO DE GOMA	1	1	
23	682-44551-02-4D	HOUSING, LOWER MOUNT RUBBER 1 CAJA AMORTIGUADOR INFERIOR HU	1	1	
24	682-44552-02-4D	HOUSING, LOWER MOUNT RUBBER 2 CAJA AMORTIGUADOR INFERIOR HU	1	1	
25	90119-08M45	BOLT, WITH WASHER TORNILLO CON ARANDELA	2	2	EXCEPT FOR YEM EXCEPT FOR YEM
26	97575-08555	BOLT, WITH WASHER PERNO CON ARANDELA	1	1	

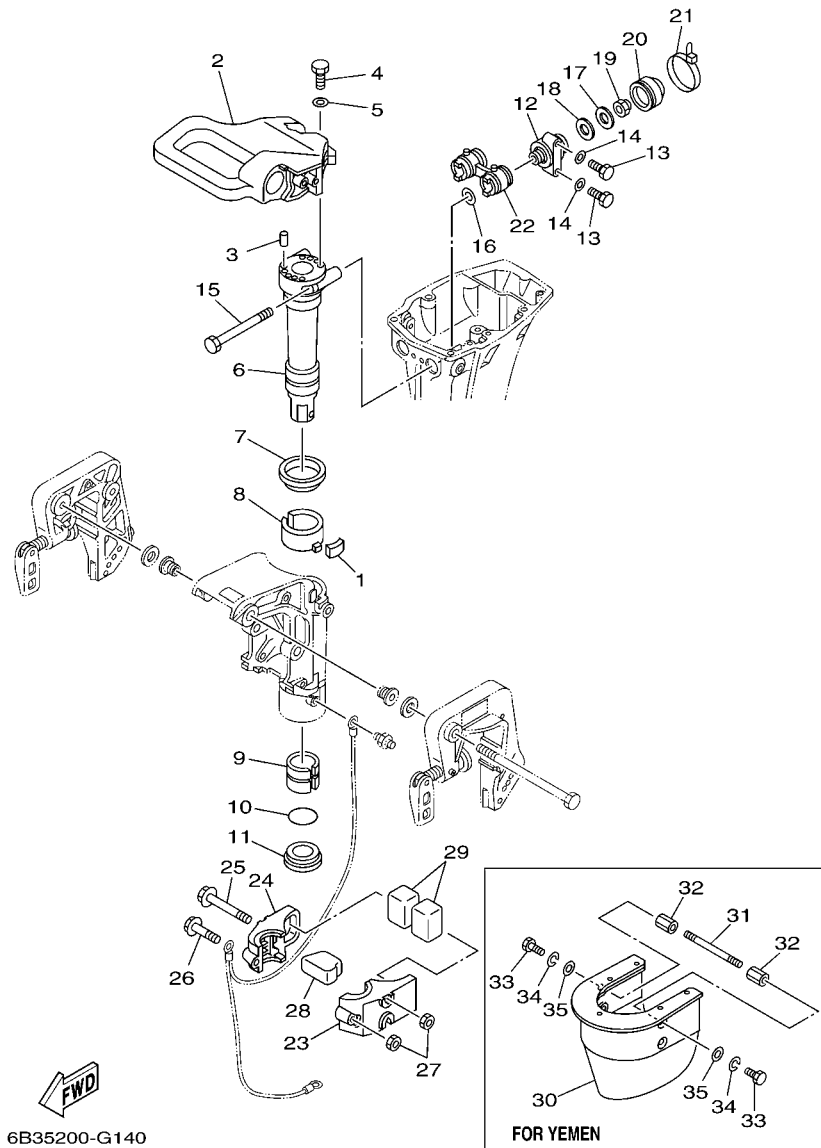

FIG. 14 BRACKET 2

SOPORTE 2

REF. NO.	PART NO. CODIGO N°	DESCRIPTION DESCRIPCION	6B39	6B49	REMARKS OBSERVACIONES
27	95380-08700	NUT TUERCA	3	3	EXCEPT FOR YEM EXCEPT FOR YEM
	95380-08700	NUT TUERCA		1	FOR YEM FOR YEM
28	682-44557-00	MOUNT DAMPER, LOWER FRONT AMORTIGUADOR DE HULE FRENTE IN	1	1	
29	682-44555-30	MOUNT DAMPER, LOWER SIDE AMORTIGUADOR DE HULE LADO INFE	2	2	S(17.4") S(17.4")
	6B4-44555-30	MOUNT DAMPER, LOWER SIDE AMORTIGUADOR DE HULE LADO INFE	2	2	L(22.4"),X(28.0") L(22.4"),X(28.0")
30	6B4-45151-00-4D	COVER, UPPER CASING CUBIERTA FUNDA SUPERIOR	1		FOR YEM FOR YEM
31	90116-08013	BOLT, STUD ESPARRAGO	2		FOR YEM FOR YEM
32	90170-08009	NUT TUERCA	4		FOR YEM FOR YEM
33	97095-08012	BOLT PERNO	4		FOR YEM FOR YEM
34	92995-08100	WASHER ARANDELA	4		FOR YEM FOR YEM
35	92990-08600	WASHER, PLATE ARANDELA PLANA	4		FOR YEM FOR YEM

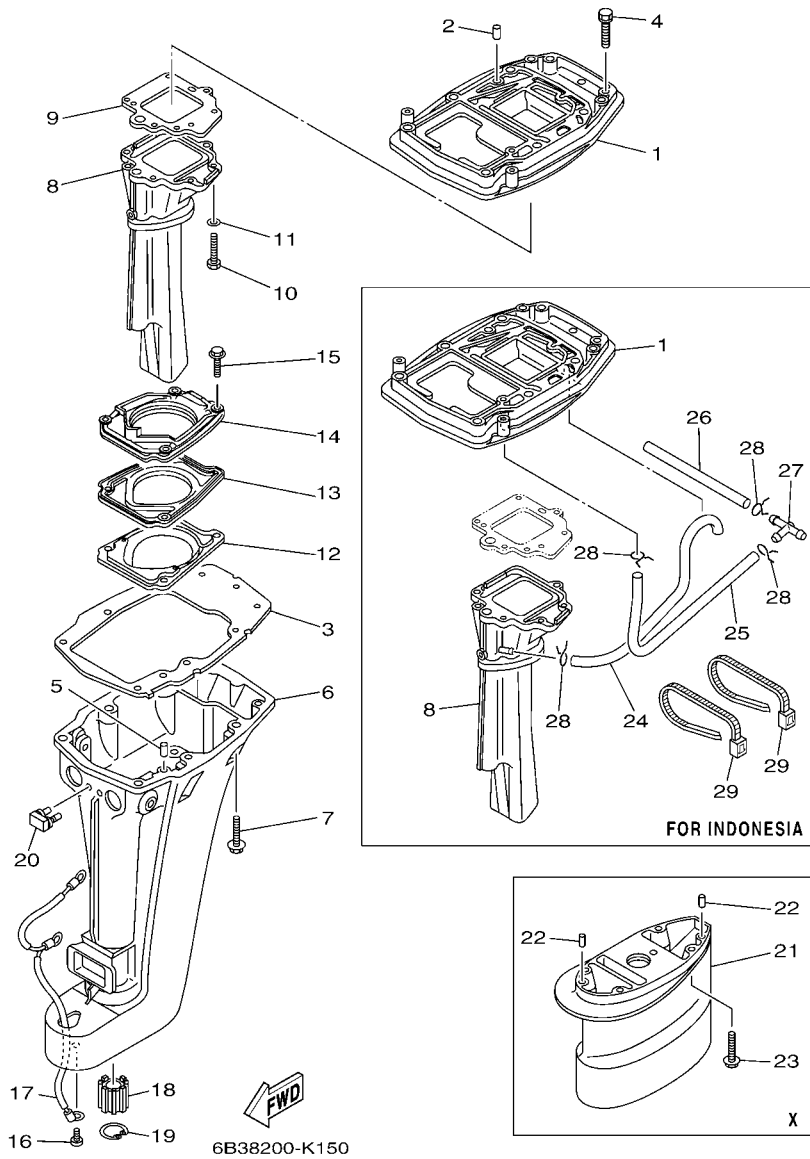

FIG. 15 UPPER CASING

FUNDA SUPERIOR

REF. NO.	PART NO. CODIGO Nº	DESCRIPTION DESCRIPCION	6B39	6B49	REMARKS OBSERVACIONES
1	6B4-41137-00-CA	GUIDE, EXHAUST GUIA DE ESCAPE	1	1	
	6B4-41137-10-CA	GUIDE, EXHAUST GUIA DE ESCAPE		1	FOR IDN FOR IDN
2	93606-12019	PIN, DOWEL PASADOR DE CLAVIJA	2	2	
3	682-45113-A2	GASKET, UPPER CASING EMPAQUE	1	1	
	6B4-45113-00	GASKET, UPPER CASING EMPAQUE		1	FOR IDN FOR IDN
4	90119-06MA4	BOLT, WITH WASHER TORNILLO CON ARANDELA	2	2	
5	93606-12019	PIN, DOWEL PASADOR DE CLAVIJA	2	2	
6	682-45111-05-4D	CASING, UPPER CAJA SUPERIOR	1	1	S(17.4") S(17.4")
	682-45111-15-4D	CASING, UPPER CAJA SUPERIOR		1	L(22.4"),X(28.0") L(22.4"),X(28.0")
7	97575-08550	BOLT, WITH WASHER PERNO CON ARANDELA	6	6	
8	6B4-41131-00-CA	MANIFOLD, EXT. 1 TUBO MULTIPLE DE ESCAPE	1	1	UR UR
	6B4-41131-10-CA	MANIFOLD, EXT. 1 TUBO MULTIPLE DE ESCAPE		1	UR ANTI-CORROSIVE UR ANTI-CORROSIVE
	6B4-41131-20-CA	MANIFOLD, EXT. 1 TUBO MULTIPLE DE ESCAPE		1	UR FOR IDN UR FOR IDN
9	682-41133-A0	GASKET, EXHAUST MANIFOLD 1 EMPAQUE ESCAPE MULTIPLE	1	1	
10	97095-06020	BOLT PERNO	6	6	
11	92995-06600	WASHER ARANDELA	6	6	
12	682-45126-01-CA	PLATE, SEAL DAMPER PLACA DE SELLO DE HULE	1	1	
13	682-45127-00	SEAL SELLO DE GOMA	1	1	
14	682-41116-00-CA	PROTECTOR PROTECTOR	1	1	S(17.4") S(17.4")
	6B4-41116-00-CA	PROTECTOR PROTECTOR		1	L(22.4"),X(28.0") L(22.4"),X(28.0")
15	90105-06M01	BOLT, FLANGE TORNILLO	4	4	
16	90157-06M06	SCREW, PAN HEAD TORNILLO CABEZA CONICA PLANA	1	1	
17	6E7-82127-00	WIRE, LEAD 2 CABLE CONDUCTOR 2	1	1	
18	6B4-45318-00	BUSHING, DRIVE SHAFT BUJE, EJE DE MANDO	1	1	L(22.4"),X(28.0") L(22.4"),X(28.0")
19	93420-30042	CIRCLIP SEGURO	1	1	L(22.4"),X(28.0") L(22.4"),X(28.0")
20	682-44532-00	STOPPER, UPPER MOUNT RETEN	1	1	
21	682-45211-31-4D	EXTENSION EXTENSION		1	X(28.0") X(28.0")

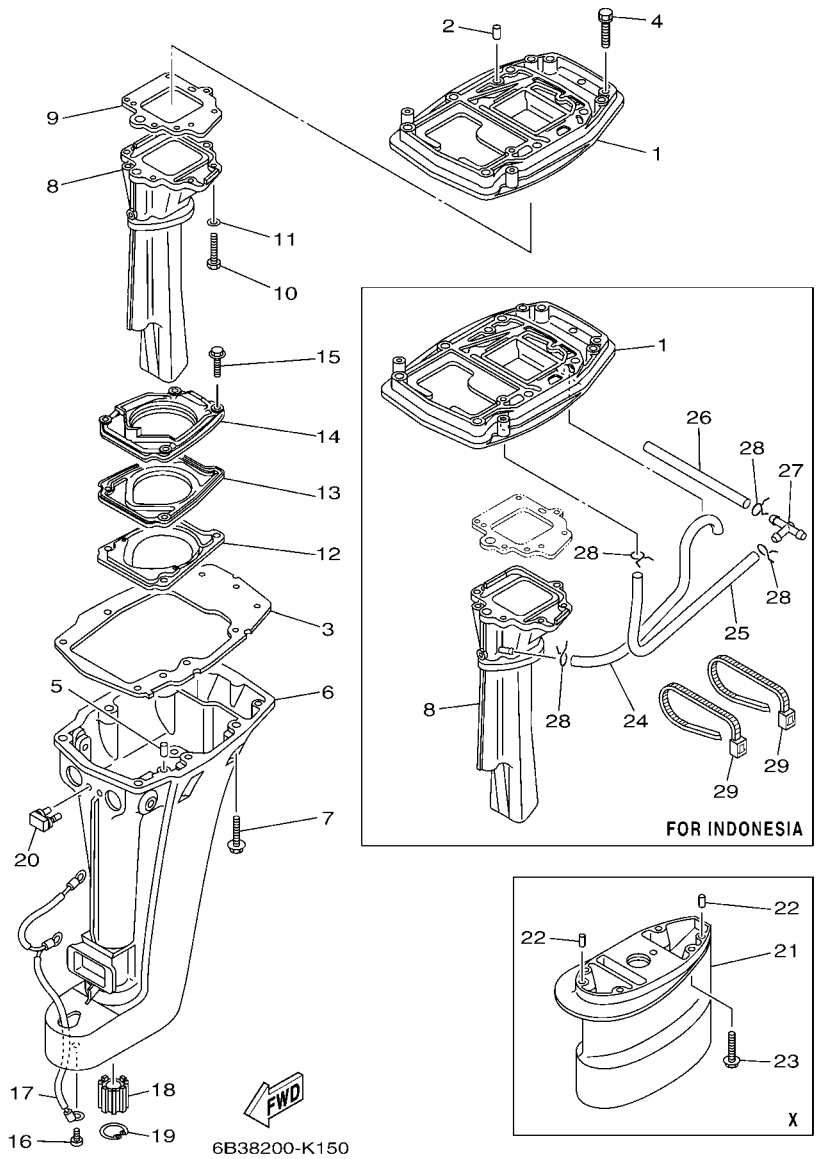

FIG. 15 UPPER CASING

FUNDA SUPERIOR

REF. NO.	PART NO. CODIGO Nº	DESCRIPTION DESCRIPCION	6B39	6B49	REMARKS OBSERVACIONES
22	93606-12019	PIN, DOWEL PASADOR DE CLAVIJA		2	X(28.0") X(28.0")
23	97575-08535	BOLT, WITH WASHER PERNO CON ARANDELA		4	X(28.0") X(28.0")
24	6B4-45135-00	PIPE TUBO 1		1	FOR IDN FOR IDN
25	90445-07022	HOSE (L110) TUBO (L110)		1	FOR IDN FOR IDN
26	90445-07MA6	HOSE (L90) TUBO (L90)		1	FOR IDN FOR IDN
27	6E0-24378-00	PIPE, JOINT 3 TUBO DE UNION 3		1	FOR IDN FOR IDN
28	90467-06016	CLIP PRESILLA		4	FOR IDN FOR IDN
29	90465-13M36	CLAMP BRIDA		2	FOR IDN FOR IDN
<hr style="border-top: 1px dashed black;"/>					
<hr style="border-top: 1px dashed black;"/>					
<hr style="border-top: 1px dashed black;"/>					
<hr style="border-top: 1px dashed black;"/>					
<hr style="border-top: 1px dashed black;"/>					
<hr style="border-top: 1px dashed black;"/>					

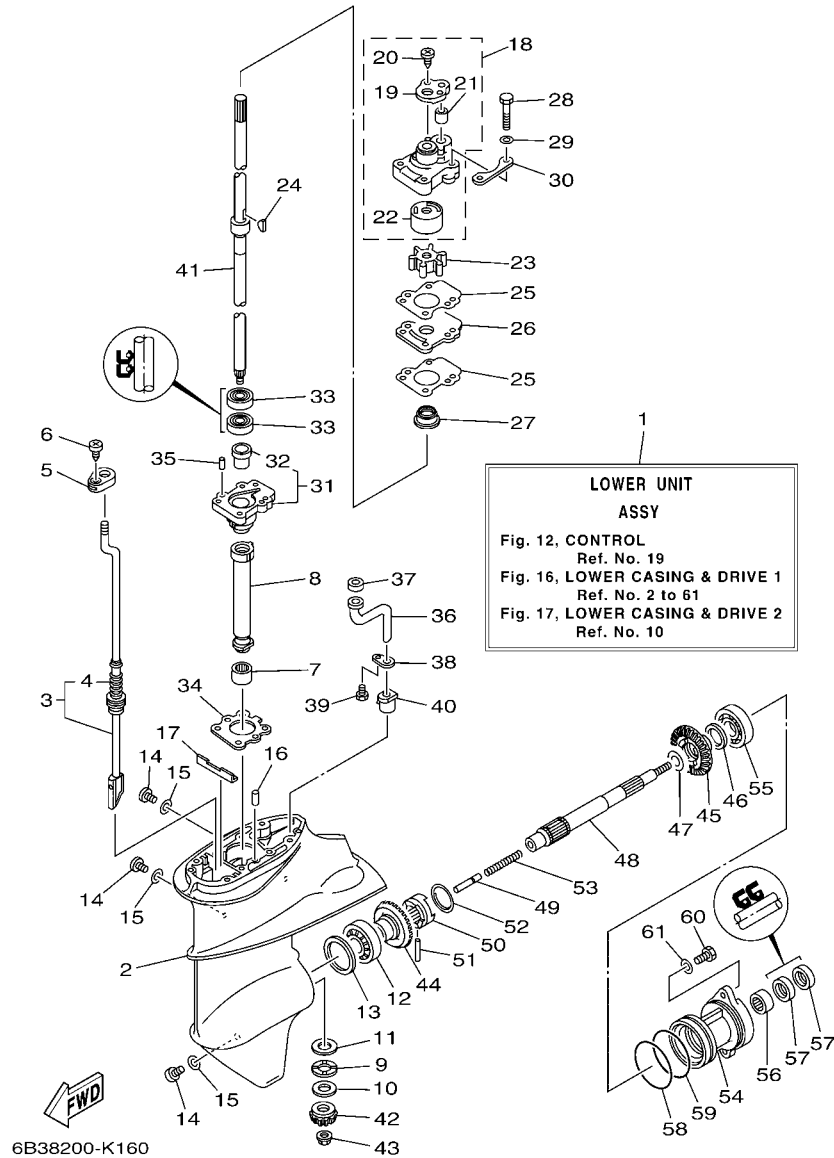

FIG. 16 LOWER CASING & DRIVE 1 IMPULSOR E INFERIOR 1

REF. NO.	PART NO. CODIGO Nº	DESCRIPTION DESCRIPCION	6B39	6B49	REMARKS OBSERVACIONES
1	6B4-45300-01-4D	LOWER UNIT ASSY CONJUNTO UNIDAD INFERIOR	1	1	S(17.4") S(17.4")
	6B4-45300-11-4D	LOWER UNIT ASSY CONJUNTO UNIDAD INFERIOR	1	1	L(22.4") L(22.4")
	6B4-45300-31-4D	LOWER UNIT ASSY CONJUNTO UNIDAD INFERIOR		1	X(28.0") X(28.0")
2	6E8-45311-01-4D	CASING, LOWER FUNDA INFERIOR	1	1	
3	6B4-44150-00	SHIFT CAM ASSY CONJUNTO EJE LEVA COMPL.	1	1	S(17.4") S(17.4")
	6B4-44150-10	SHIFT CAM ASSY CONJUNTO EJE LEVA COMPL.	1	1	L(22.4") L(22.4")
	6B4-44150-30	SHIFT CAM ASSY CONJUNTO EJE LEVA COMPL.		1	X(28.0") X(28.0")
4	6B4-44147-00	.BOOT, SHIFT ROD .HULE DE VARILLA	1	1	
5	682-44176-00	BRACKET SOPORTE	1	1	
6	97780-50110	SCREW, TAPPING TORNILLO DE CABEZA DE CONO ACH	1	1	
7	93315-314V8	BEARING COJINETE DE RODILLOS	1	1	
8	6E7-45536-00	SLEEVE, DRIVE SHAFT CAMISA EJE DE MANDO	1	1	
9	90209-14011	WASHER ARANDELA DE SEPARACION	1	1	
10	6E8-45587-10	SHIM (T:1.13MM) LAINA (T:1.13MM)	1	1	UR UR
	6E8-45587-30	SHIM (T:1.20MM) LAINA (T:1.20MM)	1	1	UR UR
11	90201-15017	WASHER, PLATE ARANDELA PLANA	1	1	
12	93332-00005	BEARING COJINETE	1	1	
13	664-45567-01	SHIM (T:0.10MM) LAINA (T:0.10MM)	1	1	UR UR
	664-45567-10	SHIM (T:0.12MM) LAINA (T:0.12MM)	1	1	UR UR
	664-45567-20	SHIM (T:0.15MM) LAINA (T:0.15MM)	1	1	UR UR
	664-45567-30	SHIM (T:0.18MM) LAINA (T:0.18MM)	1	1	UR UR
	664-45567-40	SHIM (T:0.30MM) LAINA (T:0.30MM)	1	1	UR UR
	664-45567-50	SHIM (T:0.40MM) LAINA (T:0.40MM)	1	1	UR UR
	664-45567-60	SHIM (T:0.50MM) LAINA (T:0.50MM)	1	1	UR UR
14	90340-08002	PLUG, STRAIGHT SCREW TORNILLO, DE DRENAJE	3	3	
15	90430-08020	GASKET JUNTA	3	3	
16	93604-08062	PIN, DOWEL PASADOR DE CLAVIJA	1	1	

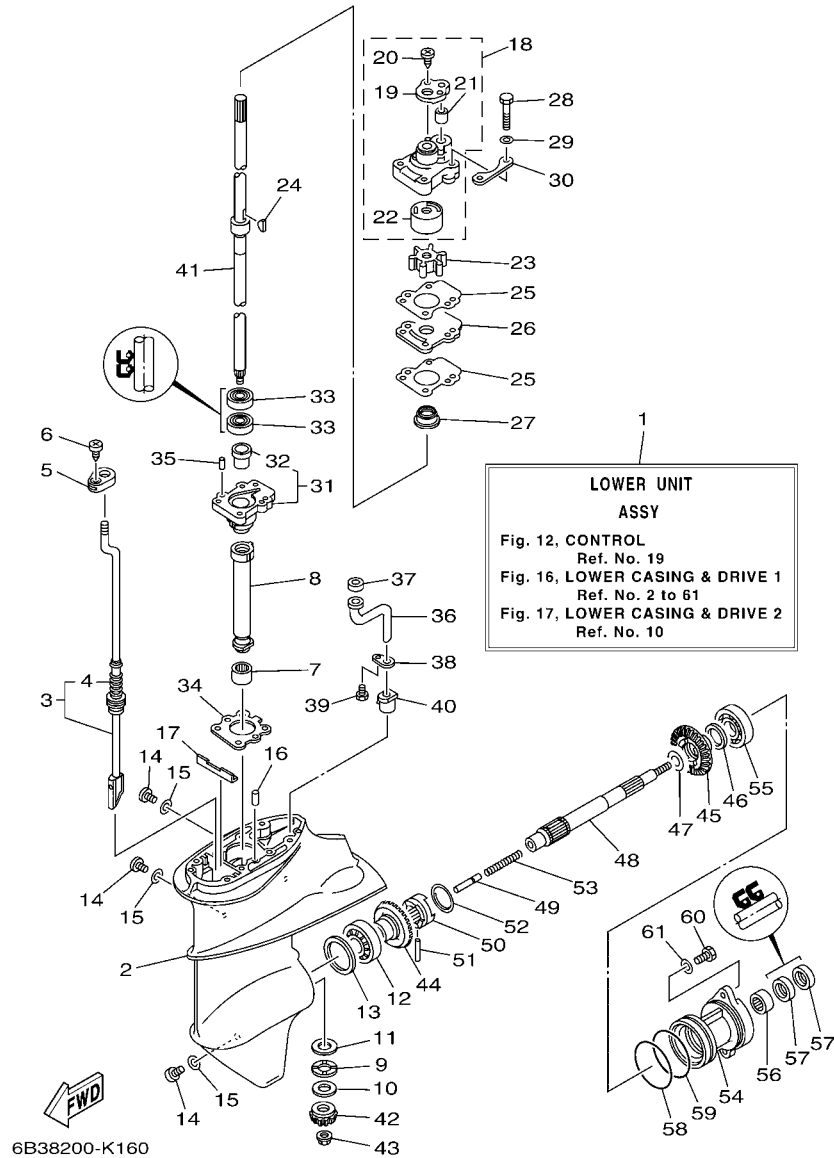

FIG. 16 LOWER CASING & DRIVE 1 IMPULSOR E INFERIOR 1

REF. NO.	PART NO. CODIGO Nº	DESCRIPTION DESCRIPCION	6B39	6B49	REMARKS OBSERVACIONES
17	682-45376-01	GUIDE, SEAL DAMPER GUIA DE SELLO GOMA	1	1	
18	682-44300-40	HOUSING WATER PUMP ASSY BOMBA DE AGUA	1	1	
19	682-44312-00	.COVER, WATER PUMP HOUSING .CUBIERTA CAJA BOMBA DE AGUA	1	1	
20	97780-40112	.SCREW, OVAL HEAD TAPPING .TORNILLO DE CABEZA DE CONO ACH	2	2	
21	682-44365-00	.DAMPER, WATER SEAL 1 .HULE DE SELLO DE AGUA 1	1	1	
22	682-44322-41	.INSERT, CARTRIDGE .CARTUCHO	1	1	
23	682-44352-03	IMPELLER IMPULSOR	1	1	
24	90280-03005	KEY, WOODRUFF CUNA WOODRUFF	1	1	
25	682-44315-A0	GASKET, WATER PUMP EMPAQUE	2	2	
26	682-44323-40	OUTER PLATE, CARTRIDGE PLACA EXTERIOR DEL CARTUCHO	1	1	
27	682-45344-00	COVER, OIL SEAL CUBIERTA SELLO ACEITE	1	1	
28	97095-06045	BOLT PERNO	4	4	
29	92995-06600	WASHER ARANDELA	4	4	
30	682-44328-00	PLATE PLACA	2	2	
31	6E7-45331-00-CA	HOUSING, BEARING CAJA DE COJINETE	1	1	
32	626-45316-09	.BUŠHING, DRIVE SHAFT .BUJE, EJE DE MANDO	1	1	
33	93101-20001	OIL SEAL SELLO ACEITE	2	2	
34	683-45315-A0	PACKING, LOWER CASING EMPAQUE	1	1	
35	93606-12019	PIN, DOWEL PASADOR DE CLAVIJA	2	2	
36	683-44362-01	TUBE, WATER 2 TUBO DE AGUA 2	1	1	
37	683-44365-01	DAMPER, WATER SEAL 1 HULE DE SELLO DE AGUA 1	1	1	
38	683-44373-00	SET PLATE, WATER TUBE PLACA PARA FIJAR TUBO	1	1	
39	97095-06010	BOLT PERNO	1	1	
40	6E7-44366-00	DAMPER, WATER SEAL 2 GOMA DEL SELLO DE AGUA 2	1	1	
41	6B4-45501-00	DRIVE SHAFT COMP. EJE DE MANDO COMPL.	1	1	S(17.4") S(17.4")
	6B4-45501-10	DRIVE SHAFT COMP. EJE DE MANDO COMPL.	1	1	L(22.4") L(22.4")
	6B4-45501-30	DRIVE SHAFT COMP. EJE DE MANDO COMPL.		1	X(28.0") X(28.0")

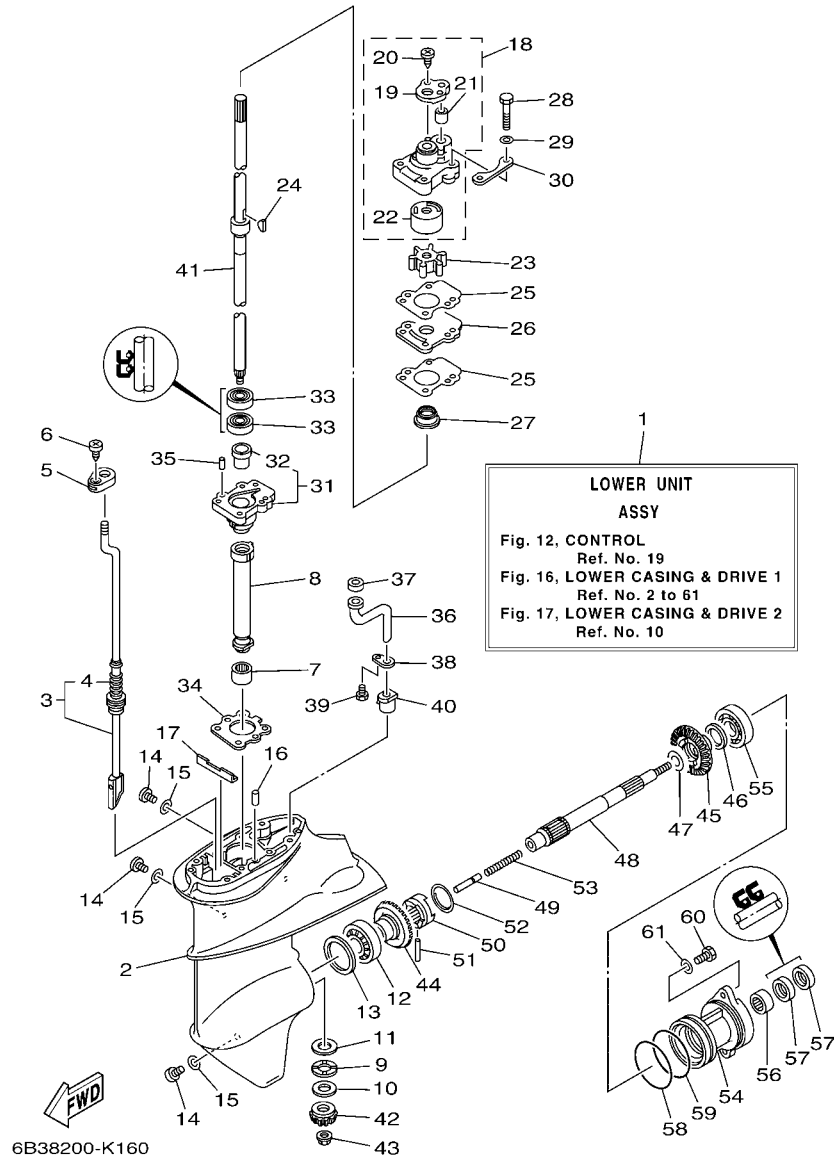

FIG. 16 LOWER CASING & DRIVE 1

IMPULSOR E INFERIOR 1

REF. NO.	PART NO. CODIGO Nº	DESCRIPTION DESCRIPCION	6B39	6B49	REMARKS OBSERVACIONES
42	63V-45551-00	PINION (13T) PINON (13T)	1	1	
43	90179-08M06	NUT TUERCA	1	1	
44	6E7-45560-01	GEAR 1 (27T) ENGRANAJE 1 (27T)	1	1	
45	6E7-45571-00	GEAR 2 (27T) ENGRANAJE 2 (27T)	1	1	
46	626-45577-00	SHIM (T:0.10MM) LAINA (T:0.10MM)	1	1	UR UR
---	626-45577-10	SHIM (T:0.20MM) LAINA (T:0.20MM)	1	1	UR UR
---	626-45577-20	SHIM (T:0.30MM) LAINA (T:0.30MM)	1	1	UR UR
---	626-45577-30	SHIM (T:0.40MM) LAINA (T:0.40MM)	1	1	UR UR
---	626-45577-40	SHIM (T:0.50MM) LAINA (T:0.50MM)	1	1	UR UR
47	90201-17682	WASHER, PLATE ARANDELA PLANA	1	1	
48	683-45611-00	SHAFT, PROPELLER EJE PROPUSOR	1	1	
49	650-45635-00	PLUNGER, SHIFT EMBOLO DE CAMBIO	1	1	
50	682-45631-00	CLUTCH, DOG EMBRAGUE DE GARRA	1	1	
51	90250-05010	PIN, STRAIGHT PASADOR CILINDRICO	1	1	
52	648-45633-00	RING, CROSS PIN ANILLO DE PASADOR	1	1	
53	90501-14M06	SPRING, COMPRESSON RESORTE DE COMPRESION	1	1	
54	683-45361-02-4D	CAP, LOWER CASING FUNDA INFERIOR	1	1	UR UR
---	6B4-45361-00-4D	CAP, LOWER CASING FUNDA INFERIOR	1	1	UR ANTI-CORROSIVE UR ANTI-CORROSIVE
55	93306-00501	BEARING COJINETE	1	1	
56	93315-317U2	BEARING COJINETE DE RODILLOS	1	1	
57	93101-17001	OIL SEAL SELLO ACEITE	2	2	
58	93210-57M09	O-RING ANILLO O	1	1	
59	93210-56M80	O-RING ANILLO O	1	1	
60	97095-06020	BOLT PERNO	2	2	
61	92995-06600	WASHER ARANDELA	2	2	

FIG. 17 LOWER CASING & DRIVE 2

IMPULSOR E INFERIOR 2

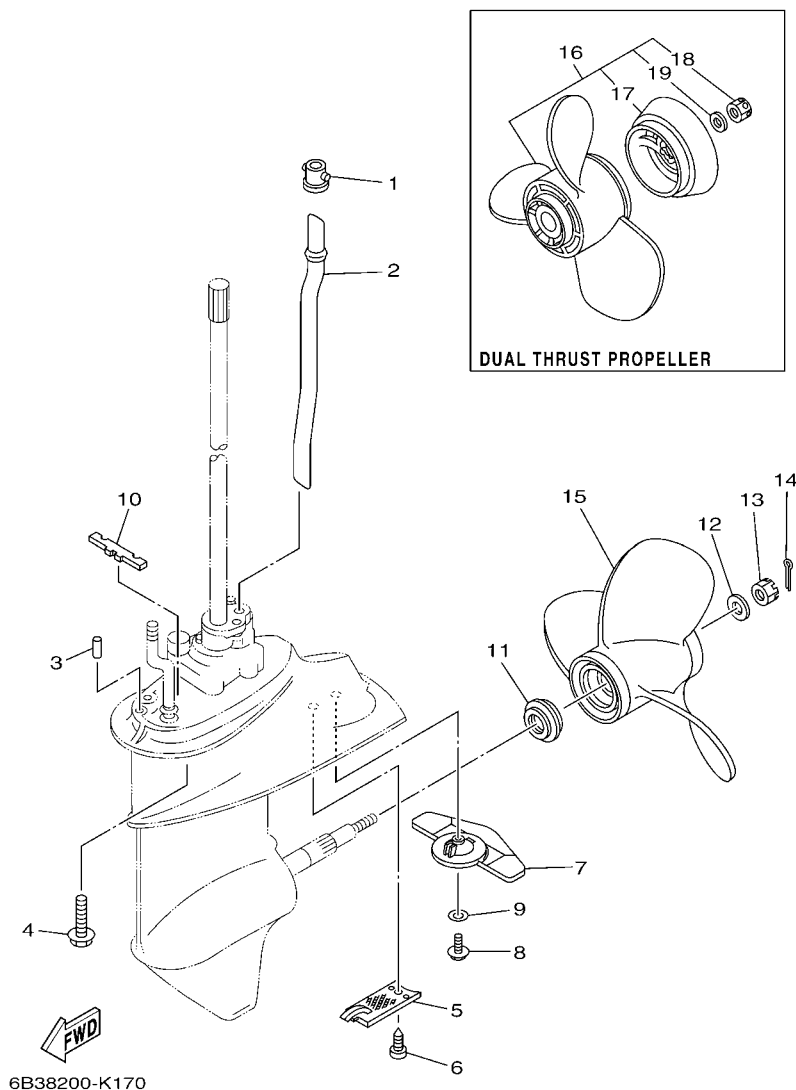

REF. NO.	PART NO. CODIGO Nº	DESCRIPTION DESCRIPCION	6B39	6B49	REMARKS OBSERVACIONES
1	626-44365-01	DAMPER, WATER SEAL 1 HULE DE SELLO DE AGUA 1	1	1	
2	682-44361-01	TUBE, WATER 1 TUBO DE AGUA 1	1	1	S(17.4") S(17.4")
	6B4-44361-10	TUBE, WATER 1 TUBO DE AGUA 1	1	1	L(22.4") L(22.4")
	6B4-44361-30	TUBE, WATER 1 TUBO DE AGUA 1		1	X(28.0") X(28.0")
3	93606-12019	PIN, DOWEL PASADOR DE CLAVIJA	2	2	
4	97575-08535	BOLT, WITH WASHER PERNO CON ARANDELA	4	4	
5	6E7-45214-00	COVER, WATER INLET 1 CUBIERTA ENTRADA AGUA 1	1	1	
6	97880-05012	SCREW, PAN HEAD TORNILLO DE CABEZA CON PLANA	1	1	
7	6B4-45251-00	ANODE CATODE	1	1	
8	95895-06020	BOLT, FLANGE TORNILLO DE REBORDE	1	1	
9	92990-06300	WASHER, INTERNAL TOOTH ARANDELA PLANA	1	1	
10	682-45375-01	DAMPER, SEAL GOMA DE SELLO	1	1	
11	6E7-45987-01	SPACER 1 ESPACIADOR 1	1	1	
12	90201-10M01	WASHER, PLATE ARANDELA PLANA	1	1	
13	90171-10M01	NUT, CASTLE TUERCA ENTALLADA	1	1	
14	91490-30020	PIN, COTTER CHAVETA	1	1	
15	683-45941-00	PROPELLER (3X9-1/4"X12"-J) PROPERA (3X9-1/4"X12"-J)	1	1	UR UR
	683-45943-00	PROPELLER (3X9-1/4"X10-1/2"-J) PROPERA (3X9-1/4"X10-1/2"-J)	1	1	UR UR
	683-45947-00	PROPELLER (3X9-1/4"X8"-J) PROPELA (3X9-1/4"X8"-J)	1	1	UR UR
	683-45949-00	PROPELLER (3X9-1/2"X6-1/2"-J) PROPELA (3X9-1/2"X6-1/2"-J)	1	1	UR UR
	683-45952-00	PROPELLER (3X9-1/4"X9-3/4"-J) PROPELA (3X9-1/4"X9-3/4"-J)	1	1	UR UR
	63V-45943-10	PROPELLER (3X9-1/4"X11"-J1) PROPELA (3X9-1/4"X11"-J1)	1	1	UR UR
	63V-45945-10	PROPELLER (3X9-1/4"X9"-J1) PROPELA (3X9-1/4"X9"-J1)	1	1	UR UR
	63V-45947-00	PROPELLER (3X9-1/4"X8"-J) PROPELA (3X9-1/4"X8"-J)	1	1	UR UR
	63V-45952-10	PROPELLER (3X9-1/4"X10"-J1) PROPELA (3X9-1/4"X10"-J1)	1	1	UR UR
16	683-W4591-02	PROPELLER (3X9-3/4"X8"-J) PROPELA (3X9-3/4"X8"-J)	1	1	UR UR
	683-W4592-02	PROPELLER (3X9-3/4"X6-1/2"-J) PROPELA (3X9-3/4"X6-1/2"-J)	1	1	UR UR

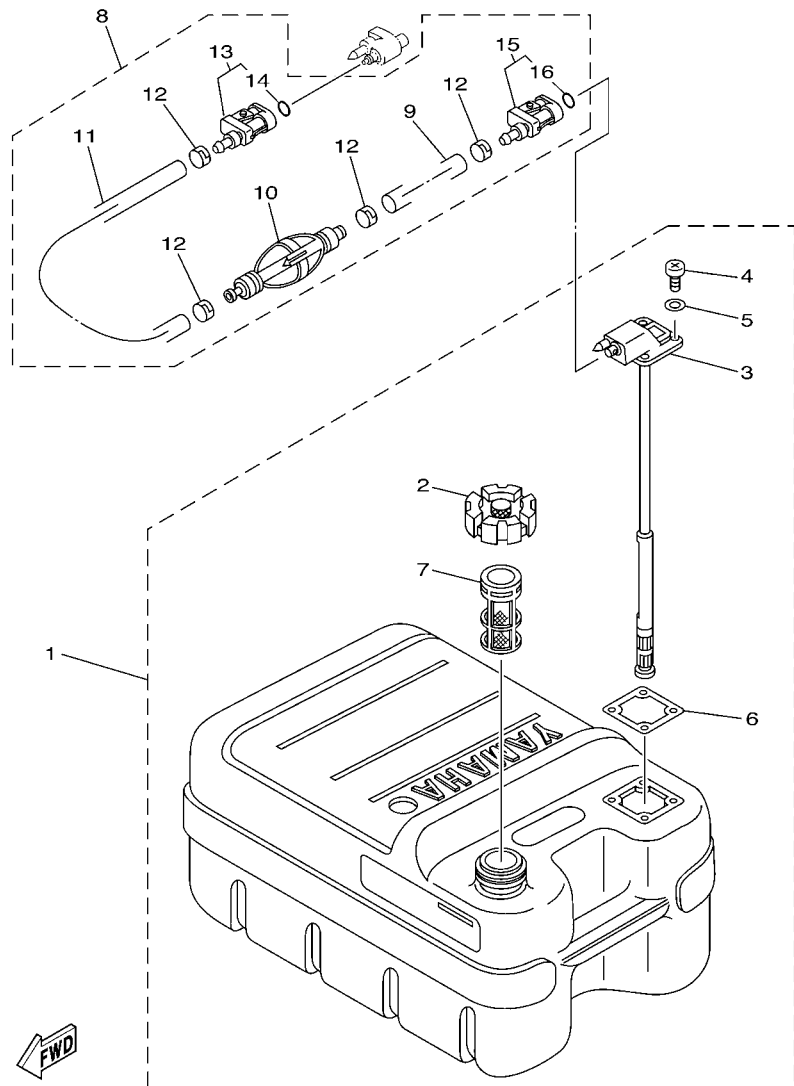

68U3100-C240

FIG. 18 FUEL TANK

DEPOSITO DE COMBUSTIBLE

REF. NO.	PART NO. CODIGO N°	DESCRIPTION DESCRIPCION	6B39	6B49	REMARKS OBSERVACIONES
1	6YJ-24201-00	FUEL TANK ASSY (24L) TANQUE DEL COMBUSTIBLE (24L)	1	1	AP AP
2	6YJ-24610-01	.CAP ASSY .TAPA COMPLETA	1	1	
3	6YJ-24260-00	.FUEL METER ASSY .MEDIDOR DE COMBUSTIBLE COMPL.	1	1	
4	90157-05M19	.SCREW, PAN HEAD .TORNILLO CABEZA CONICA PLANA	4	4	
5	6Y1-24329-00	.SEAL .SELLO	4	4	
6	6Y1-24268-00	.GASKET, FUEL METER .EMPAQ MEDIDOR DE COMBUSTIBLE	1	1	
7	6YJ-24167-00	.STRAINER .COLADOR	1	1	
8	61J-24306-04	FUEL PIPE COMP. 1 TUBO COMBUST. COMPL 1	1	1	AP AP
9	90445-11M06	.HOSE (L2050) .MANGUERA (L2050)	1	1	
10	61J-24360-00	.PRIMER PUMP ASSY .SOPORTE BOMBA	1	1	
11	90445-11M05	.HOSE (L850) .MANGUERA (L850)	1	1	
12	650-24351-51	.BAND 1 .ABRAZADERA 1	4	4	
13	6G1-24305-05	.FUEL PIPE JOINT COMP. 2 .CONECTOR MANGUERA COMBUST. 2	1	1	
14	93210-08287	..O-RING ..ANILLO O	1	1	
15	6Y1-24305-06	.FUEL PIPE JOINT COMP. 2 .CONECTOR MANGUERA COMBUST. 2	1	1	
16	93210-08287	..O-RING ..ANILLO O	1	1	

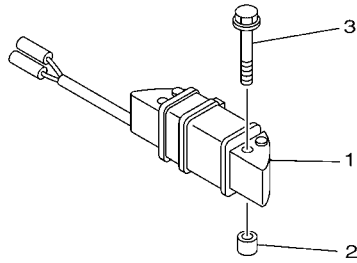

 6B39200-L190

FIG. 19 OPTIONAL PARTS

PARTES OPCIONALES

REF. NO.	PART NO. CODIGO Nº	DESCRIPTION DESCRIPCION	6B39	6B49		REMARKS OBSERVACIONES
1	63V-85533-00	COIL, LIGHTING BOBINA DE LUZ	1	1		AP AP
2	90387-06M24	COLLAR ESPACIADOR	2	2		AP AP
3	90119-06M40	BOLT, WITH WASHER TORNILLO CON ARANDELA	2	2		AP AP

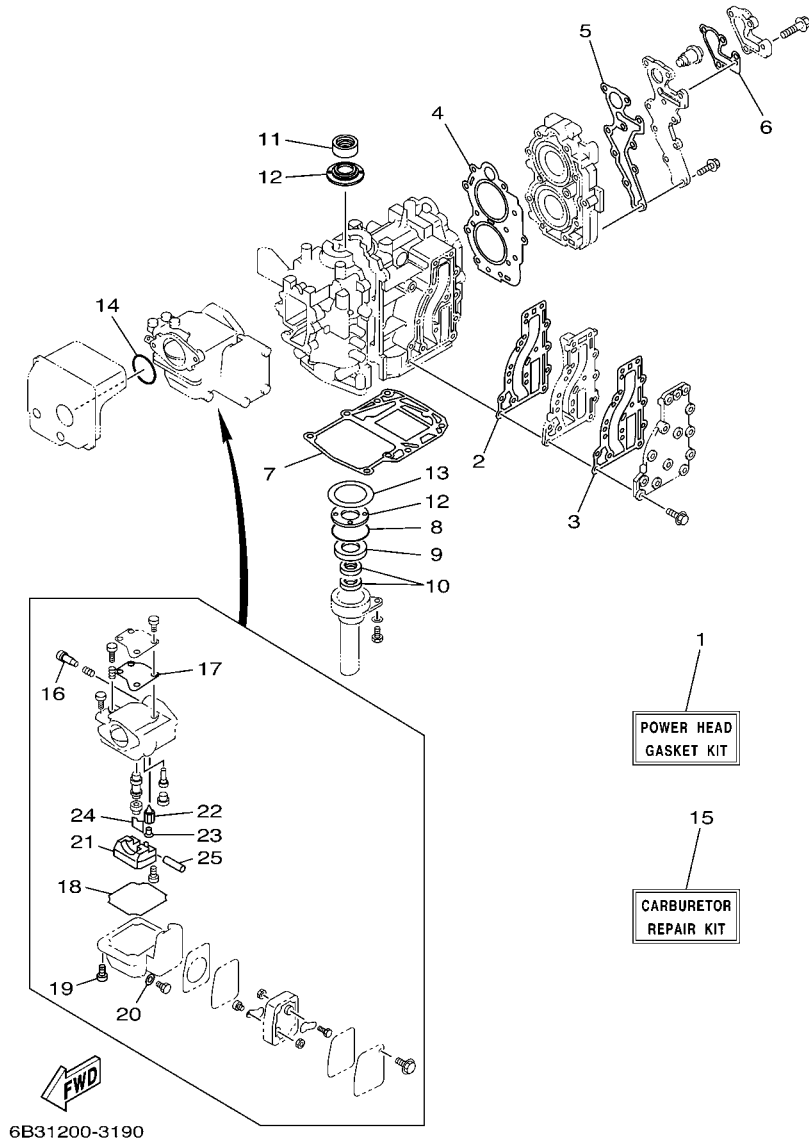

FIG. 20 REPAIR KIT 1

ESTUCHE REPARATION 1

REF. NO.	PART NO. CODIGO Nº	DESCRIPTION DESCRIPCION	6B39	6B49		REMARKS OBSERVACIONES
1	6B4-W0001-00	POWER HEAD GASKET KIT JUEGO DE EMPAQUE DE MOTOR	1	1		
2	6B4-41112-A0	.GASKET, EXHAUST INNER COVER .EMPAQUE	1	1		
3	63V-41112-A0	.GASKET, EXHAUST INNER COVER .EMPAQUE	1	1		
4	63V-11181-A2	.GASKET, CYLINDER HEAD 1 .JUNTA, DE CULATA 1	1	1		
5	6B4-11193-A1	.GASKET, HEAD COVER 1 .EMPAQUE	1	1		
6	682-12414-A1	.GASKET, COVER .EMPAQUE	1	1		
7	6B4-11351-A1	.GASKET, CYLINDER .JUNTA, DE CILINDRO	1	1		
8	93210-46M16	.O-RING .ANILLO O	1	1		
9	93102-25010	.OIL SEAL .SELLO ACEITE	1	1		
10	93101-13M27	.OIL SEAL .SELLO ACEITE	2	2		
11	93110-23M00	.OIL SEAL .SELLO ACEITE	1	1		
12	63V-11445-00	.SPACER .ESPACIADOR	2	2		
13	90201-46M29	.WASHER, PLATE .ARANDELA PLANA	1	1		
14	93210-35M86	.O-RING .ANILLO O	1	1		
15	63V-W0093-00	CARBURETOR REPAIR KIT KIT REPARACION CARBURADOR	1	1		
16	679-14923-00	.SCREW, PILOT .TORNILLO DE AJUSTE	1	1		
17	63V-14126-00	.GASKET .EMPAQUE	1	1		
18	63V-14984-00	.GASKET, FLOAT CHAMBER .EMPAQUE CAMARA DE BOIA	1	1		
19	97980-04114	.SCREW, WITH WASHER .TORNILLO, CON ARANDELA	4	4		
20	65W-14398-00	.GASKET .EMPAQUE	1	1		
21	63V-14985-00	.FLOAT .BOIA	1	1		
22	6G1-14546-01	.VALVE, NEEDLE .VALVULA DE AGUJA	1	1		
23	676-14186-00	.PIN, FLOAT .PASADOR DE LA BOYA	1	1		
24	663-14159-00	.CLIP .PRESILLA	1	1		
25	6H4-14548-00	.PIN, FLOAT ARM .PASADOR DE BRAZO DE BOIA	1	1		

FIG. 21 REPAIR KIT 2

ESTUCHE REPARATION 2

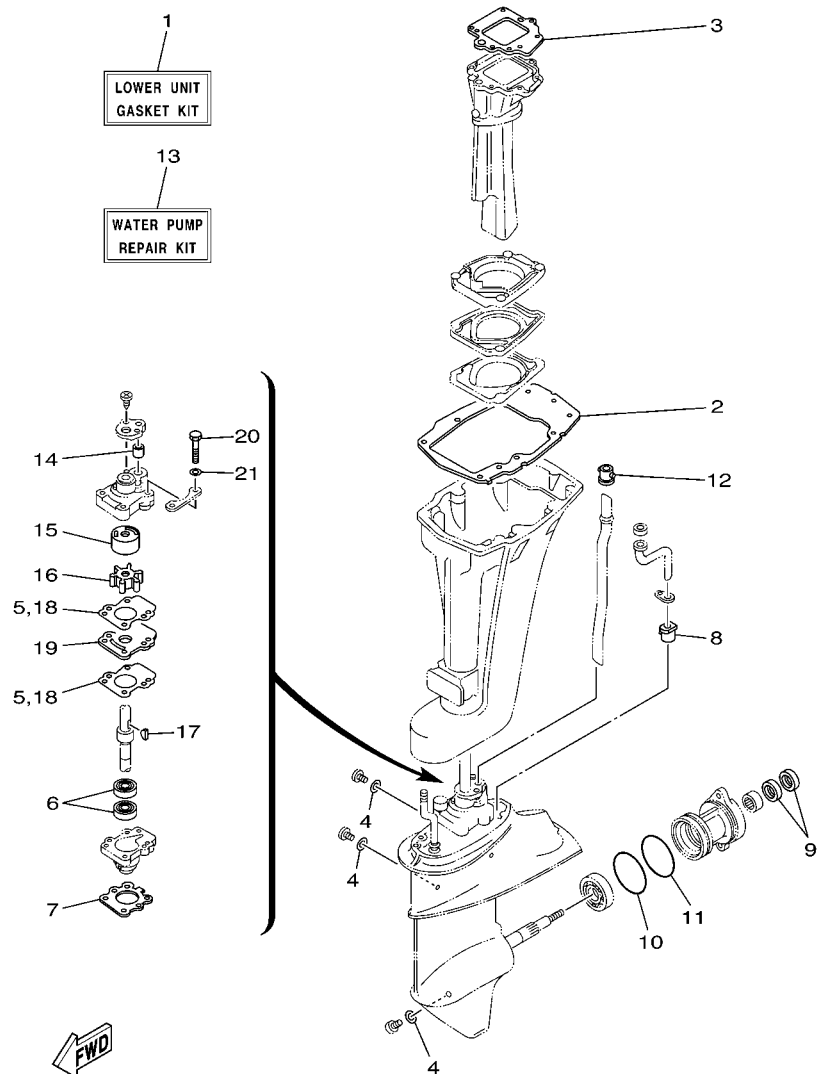

6B31200-3200

REF. NO.	PART NO. CODIGO Nº	DESCRIPTION DESCRIPCION	6B39	6B49	REMARKS OBSERVACIONES
1	6B4-W0001-20	LOWER UNIT GASKET KIT JUEGO DE EMPAQUE UNIDAD INFER.	1	1	
2	682-45113-A2	.GASKET, UPPER CASING .EMPAQUE	1	1	
3	682-41133-A0	.GASKET, EXHAUST MANIFOLD 1 .EMPAQUE ESCAPE MULTIPLE	1	1	
4	90430-08020	.GASKET .JUNTA	3	3	
5	682-44315-A0	.GASKET, WATER PUMP .EMPAQUE	2	2	
6	93101-20001	.OIL SEAL .SELLO ACEITE	2	2	
7	683-45315-A0	.PACKING, LOWER CASING .EMPAQUE	1	1	
8	6E7-44366-00	.DAMPER, WATER SEAL 2 .GOMA DEL SELLO DE AGUA 2	1	1	
9	93101-17001	.OIL SEAL .SELLO ACEITE	2	2	
10	93210-57M09	.O-RING .ANILLO O	1	1	
11	93210-56M80	.O-RING .ANILLO O	1	1	
12	626-44365-01	.DAMPER, WATER SEAL 1 .HULE DE SELLO DE AGUA 1	1	1	
13	6B4-W0078-0A	WATER PUMP REPAIR KIT ESTUCHE REPARACION BOMBA AGUA	1	1	
14	682-44365-00	.DAMPER, WATER SEAL 1 .HULE DE SELLO DE AGUA 1	1	1	
15	682-44322-41	.INSERT, CARTRIDGE .CARTUCHO	1	1	
16	682-44352-03	.IMPELLER .IMPULSOR	1	1	
17	90280-03005	.KEY, WOODRUFF .CUNA WOODRUFF	1	1	
18	682-44315-A0	.GASKET, WATER PUMP .EMPAQUE	2	2	
19	682-44323-40	.OUTER PLATE, CARTRIDGE .PLACA EXTERIOR DEL CARTUCHO	1	1	
20	97095-06045	.BOLT .PERNO	4	4	
21	92995-06600	.WASHER .ARANDELA	4	4	

NUMERICAL INDEX
INDICE NUMERICO

PART NO. CODIGO N°	REF. NO.	PART NO. CODIGO N°	REF. NO.	PART NO. CODIGO N°	REF. NO.	PART NO. CODIGO N°	REF. NO.	PART NO. CODIGO N°	REF. NO.	PART NO. CODIGO N°	REF. NO.
6B4-11111-00-1S	2 - 18	63V-14523-00	5 - 9	6A0-15789-00	7 - 29	6J8-41262-00	12 - 29	6B4-43181-00	13 - 43	6E7-44366-00	16 - 40
63V-11181-A2	2 - 19	63V-14527-00	5 - 4	63V-15794-00	7 - 15	6B4-41271-01	4 - 10	682-43311-07-4D	13 - 22		21 - 8
	20 - 4	6G1-14546-01	5 - 19	6YJ-24167-00	18 - 7	6B4-41273-00	4 - 11	682-43318-01	13 - 52	683-44373-00	16 - 38
6B4-11191-00-1S	2 - 21		20 - 22	6YJ-24201-00	18 - 1	6B4-41274-00	4 - 12		13 - 54	6BL-44391-00	10 - 13
6B4-11193-A1	2 - 22	6H4-14548-00	5 - 22	6YJ-24260-00	18 - 3	6B4-41283-00	12 - 6	676-43373-00	13 - 26	682-44514-01-94	14 - 12
	20 - 5		20 - 25	6Y1-24268-00	18 - 6	6B4-41638-00	12 - 10	682-43611-01	13 - 37	682-44514-31-94	14 - 12
682-11325-00	2 - 7	679-14555-00	5 - 3	6G1-24304-02	6 - 1	6B4-41662-00	12 - 21	682-43614-01	13 - 35	682-44521-01	14 - 22
6B4-11351-A1	2 - 29	679-14923-00	5 - 2	6G1-24305-05	18 - 13	6B4-42111-00-4D	11 - 1	682-43615-02	13 - 36	682-44522-01	14 - 20
	20 - 7		20 - 16	6Y1-24305-06	18 - 15	6B4-42119-00	11 - 15	682-43616-00	13 - 30	682-44532-00	15 - 20
676-11372-00	2 - 15	676-14943-29	5 - 14	61J-24306-04	18 - 8	6B4-42125-00	11 - 11	682-43617-00	13 - 34	682-44551-02-4D	14 - 23
6B4-11400-00	3 - 7	676-14943-79	5 - 14	6J8-24311-00	7 - 28	6B4-42126-00	11 - 12	682-43627-00	13 - 44	682-44552-02-4D	14 - 24
63V-11412-00	3 - 8	63V-14947-00	5 - 13	6B4-24329-00	6 - 14	6B4-42131-00-4D	11 - 6	6B4-43631-00	13 - 28	682-44555-30	14 - 29
63V-11422-00	3 - 9	6B3-14947-00	5 - 13	6Y1-24329-00	18 - 5	6F5-42137-00	11 - 16	682-43641-01	13 - 31	6B4-44555-30	14 - 29
63V-11432-00	3 - 10	63V-14948-06	5 - 7	650-24351-51	18 - 12	6B4-42138-00	11 - 23	682-43643-00	13 - 55	682-44557-00	14 - 28
63V-11442-00	3 - 11	679-14966-00	5 - 8	61J-24360-00	18 - 10	6G1-42177-00	11 - 18	682-43659-01	13 - 39	682-45111-05-4D	15 - 6
63V-11445-00	3 - 28	63V-14980-00	5 - 12	6E0-24378-00	15 - 27	6B4-42511-00-4D	14 - 2	6B4-43681-00	13 - 53	682-45111-15-4D	15 - 6
	20 - 12	63V-14984-00	5 - 11	63V-24411-00	5 - 28	682-42521-00-94	14 - 6	6B4-44111-00-4D	12 - 11	6B4-45113-00	15 - 3
63V-11515-02	3 - 14		20 - 18	6G1-24411-00	5 - 30	648-42528-00	14 - 1	6B4-44116-00	12 - 16	682-45113-A2	15 - 3
682-11610-01	3 - 22	63V-14985-00	5 - 18	6G1-24412-01	5 - 29	682-42537-00	14 - 8	6B4-44121-00	12 - 12		21 - 2
682-11610-11	3 - 22		20 - 21	6L5-24421-00	5 - 32	6B3-42610-20	1 - 1	6B4-44125-00	12 - 14	682-45126-01-CA	15 - 12
682-11610-21	3 - 22	6G1-14992-00	5 - 17	6G1-24431-01	5 - 31	6B4-42610-40	1 - 1	6B4-44143-00	12 - 18	682-45127-00	15 - 13
6E7-11631-00-97	3 - 21	6B4-15100-00	2 - 2	6G1-24452-00	5 - 27	6B4-42610-50	1 - 1	61N-44146-00	12 - 20	6B4-45135-00	15 - 24
634-11633-00	3 - 23	6B4-15396-00-CA	3 - 1	61N-24521-00	6 - 6	6B4-42613-10	1 - 7	6B4-44147-00	16 - 4	6B4-45151-00-4D	14 - 30
6E7-11635-00	3 - 21	6B4-15663-00	7 - 30	61N-24560-00	6 - 4	6B4-42615-00	1 - 2	6B4-44150-00	16 - 3	682-45211-31-4D	15 - 21
6E7-11636-00	3 - 21	63V-15705-01	7 - 9	61N-24563-00	6 - 5	6B4-42646-00	1 - 13	6B4-44150-10	16 - 3	6E7-45214-00	17 - 5
6K4-11651-00	3 - 16	6B4-15710-00	7 - 1	648-24566-02	6 - 12	6B4-42647-00	1 - 5	6B4-44150-30	16 - 3	6B4-45251-00	17 - 7
682-11681-00	3 - 15	6B4-15711-00	7 - 2	6YJ-24610-01	18 - 2	6B4-42651-00	1 - 3	682-44176-00	16 - 5	6B4-45300-01-4D	16 - 1
6E5-12411-30	2 - 25	63V-15713-00	7 - 7	6B4-26301-00	11 - 24	63V-42678-40	1 - 10	682-44300-40	16 - 18	6B4-45300-11-4D	16 - 1
688-12412-00	2 - 26	63V-15714-00	7 - 5	61N-26326-00	10 - 2		1 - 11	682-44312-00	16 - 19	6B4-45300-31-4D	16 - 1
682-12413-00-1S	2 - 24	63V-15716-00	7 - 8	63V-41111-00-1S	2 - 11	63W-42678-40	1 - 10	682-44315-A0	16 - 25	6E8-45311-01-4D	16 - 2
682-12414-A1	2 - 27	63V-15726-00	7 - 19	63V-41112-A0	2 - 13		1 - 11		21 - 5	683-45315-A0	16 - 34
	20 - 6	63V-15734-00	7 - 17		20 - 3	6E0-42681-40	1 - 14		21 - 18		21 - 7
63W-13610-00	4 - 1	63V-15741-00	7 - 6	6B4-41112-A0	2 - 12		1 - 15	682-44322-41	16 - 22	626-45316-09	16 - 32
63V-13610-10	4 - 1	63V-15744-00	7 - 12		20 - 2	6B4-42711-00-4D	10 - 1		21 - 15	6B4-45318-00	15 - 18
63V-14126-00	5 - 5	6B4-15746-00	12 - 23	63V-41113-00-1S	2 - 14	6B4-42716-00	10 - 12	682-44323-40	16 - 26	6E7-45331-00-CA	16 - 31
	20 - 17	6L2-15747-00	12 - 28	682-41116-00-CA	15 - 14	6B4-42727-00	10 - 3		21 - 19	682-45344-00	16 - 27
663-14159-00	5 - 21	63V-15748-00	7 - 16	6B4-41116-00-CA	15 - 14	6AH-42794-40	10 - 20	682-44328-00	16 - 30	6B4-45361-00-4D	16 - 54
	20 - 24	6G1-15755-00	7 - 20	6B4-41131-00-CA	15 - 8	6B4-42815-00-4D	10 - 4	682-44352-03	16 - 23	683-45361-02-4D	16 - 54
676-14186-00	5 - 20	6B4-15758-10	7 - 22	6B4-41131-10-CA	15 - 8	6B4-42816-00	10 - 5		21 - 16	682-45375-01	17 - 10
	20 - 23	6B4-15761-00	1 - 12	6B4-41131-20-CA	15 - 8	682-43111-05-4D	13 - 1	682-44361-01	17 - 2	682-45376-01	16 - 17
6B3-14301-00	5 - 1	6B4-15762-00	7 - 23	682-41133-A0	15 - 9	682-43112-05-4D	13 - 2	6B4-44361-10	17 - 2	6B4-45501-00	16 - 41
6B4-14301-00	5 - 1	63V-15764-00	7 - 3		21 - 3	6B4-43113-00	13 - 12	6B4-45501-30	17 - 2	6B4-45501-10	16 - 41
65W-14398-00	5 - 16	68T-15764-00	7 - 4	6B4-41137-00-CA	15 - 1	648-43114-01	13 - 8	683-44362-01	16 - 36	6B4-45501-30	16 - 41
	20 - 20	63V-15767-01	7 - 10	6B4-41137-10-CA	15 - 1	6E7-43116-00	13 - 7	682-44365-00	16 - 21	6E7-45536-00	16 - 8
6B4-14440-00	4 - 5	63V-15768-00	7 - 13	63V-41211-00	12 - 8	663-43118-01-4D	13 - 5		21 - 14	63V-45551-00	16 - 42
624-14485-00	2 - 3	6B4-15770-00	12 - 30	6B4-41252-00	4 - 14	66T-43144-00	10 - 14	626-44365-01	17 - 1	6E7-45560-01	16 - 44
650-14485-03	2 - 4	6G1-15779-00	7 - 21	6B4-41262-00	4 - 13	689-43160-00	13 - 18		21 - 12	664-45567-01	16 - 13
63V-14497-02	12 - 1	68T-15784-00	7 - 11	6J8-41262-00	12 - 9	689-43165-00	13 - 19	683-44365-01	16 - 37	664-45567-10	16 - 13

NUMERICAL INDEX
INDICE NUMERICO

PART NO. CODIGO N°	REF. NO.	PART NO. CODIGO N°	REF. NO.	PART NO. CODIGO N°	REF. NO.	PART NO. CODIGO N°	REF. NO.	PART NO. CODIGO N°	REF. NO.	PART NO. CODIGO N°	REF. NO.
664-45567-20	16 - 13	6B4-85570-00	9 - 3	90201-10M01	17 - 12	90445-07MA6	15 - 26	92995-06600	7 - 25	93440-52009	3 - 20
664-45567-30	16 - 13		9 - 4	90201-10M02	11 - 20	90445-09104	2 - 16		8 - 6	93450-15023	3 - 26
664-45567-40	16 - 13	6B4-85580-00	8 - 2		17 - 19		6 - 9		8 - 9	93602-14104	3 - 24
664-45567-50	16 - 13	6B4-W0001-00	20 - 1	90201-12018	13 - 10	90445-09M00	6 - 10		9 - 12	93604-08062	16 - 16
664-45567-60	16 - 13	6B4-W0001-20	21 - 1	90201-12472	8 - 15	90445-11M05	18 - 11		9 - 17	93606-12019	2 - 9
6E7-45571-00	16 - 45	6B2-W0004-00	4 - 2	90201-14377	3 - 25	90445-11M06	18 - 9		9 - 20		14 - 3
626-45577-00	16 - 46	677-W0070-10	1 - 9	90201-15017	16 - 11	90464-08M02	9 - 14		10 - 11		15 - 2
626-45577-10	16 - 46	6B4-W0078-0A	21 - 13	90201-17682	16 - 47	90465-06M90	8 - 7		12 - 5		15 - 5
626-45577-20	16 - 46	6B4-W0090-00-1S	2 - 1	90201-28013	11 - 4		9 - 13		12 - 27		15 - 22
626-45577-30	16 - 46	63V-W0093-00	20 - 15	90201-46M29	3 - 29	90465-08M99	9 - 18		14 - 5		16 - 35
626-45577-40	16 - 46	656-W2810-02	6 - 15		20 - 13	90465-11M10	9 - 7		14 - 14		17 - 3
6E8-45587-10	16 - 10	683-W4591-02	17 - 16	90202-10M56	13 - 50	90465-11M52	14 - 21		15 - 11	93700-06M03	13 - 23
6E8-45587-30	16 - 10	683-W4592-02	17 - 16	90202-13M02	14 - 18	90465-13M36	15 - 29		16 - 29	94702-00160	2 - 30
683-45611-00	16 - 48	90101-06M29	13 - 15	90206-10M24	13 - 49	90467-06016	2 - 6		16 - 61	94702-00247	2 - 30
682-45631-00	16 - 50	90101-08M30	14 - 15	90206-12052	10 - 8		15 - 28		21 - 21	95380-03600	5 - 25
648-45633-00	16 - 52	90101-12013	13 - 9	90206-28001	11 - 5	90467-08004	6 - 11	92995-08100	14 - 34	95380-06600	11 - 13
650-45635-00	16 - 49	90102-08M01	13 - 58	90209-14011	16 - 9	90480-25161	9 - 8	92995-08600	11 - 8	95380-06700	12 - 19
683-45941-00	17 - 15	90105-06M01	15 - 15	90209-20M23	3 - 18		9 - 10		11 - 10		13 - 17
683-45943-00	17 - 15	90105-07M05	2 - 20	90209-52M01	14 - 7	90501-10326	5 - 10	93101-13M27	3 - 4	95380-08600	6 - 8
63V-45943-10	17 - 15	90109-06M05	13 - 42	90243-04007	13 - 6	90501-14M06	16 - 53		20 - 10	95380-08700	14 - 27
63V-45945-10	17 - 15	90109-06M80	10 - 15	90249-06M23	13 - 32	90501-18M00	13 - 24	93101-17001	16 - 57		14 - 27
63V-45947-00	17 - 15		12 - 17	90249-10003	13 - 45	90501-23215	11 - 21		21 - 9	95680-06100	13 - 47
683-45947-00	17 - 15	90109-06M81	12 - 22	90250-05010	16 - 51	90502-10M07	13 - 21	93101-20001	16 - 33	95780-12300	13 - 13
683-45949-00	17 - 15	90116-08013	14 - 31	90266-04005	1 - 6	90506-12002	13 - 46		21 - 6	95895-06020	17 - 8
683-45952-00	17 - 15	90119-06023	2 - 23	90266-04M00	1 - 4	90506-18009	10 - 16	93102-25010	3 - 3	95895-06065	12 - 3
63V-45952-10	17 - 15	90119-06M40	8 - 11	90269-02M09	11 - 17	90506-26M01	13 - 41		20 - 9	97013-06010	6 - 13
6E7-45986-00	17 - 17		19 - 3	90280-03005	16 - 24	90506-26M07	13 - 41	93110-23M00	3 - 27	97075-08025	13 - 27
6E7-45987-01	17 - 11	90119-06M82	7 - 27		21 - 17	90508-08M39	12 - 25		20 - 11	97095-06008	13 - 56
6AH-81994-40	7 - 32	90119-06M83	9 - 2	90280-05013	8 - 13	90508-14018	13 - 29	93210-08287	18 - 14	97095-06010	9 - 19
6AH-81995-40	7 - 31	90119-06MA3	2 - 28	90340-08002	16 - 14	90508-20M38	12 - 7		18 - 16		16 - 39
703-82119-00	8 - 12	90119-06MA4	2 - 17	90381-12001	13 - 11	91490-16010	11 - 14	93210-32738	6 - 7	97095-06012	12 - 4
6E7-82127-00	15 - 17		15 - 4	90381-20001	11 - 3	91490-16018	7 - 18	93210-35M86	4 - 9	97095-06014	9 - 16
6E5-82148-00	13 - 3	90119-08M07	2 - 10	90381-35001	11 - 2	91490-20015	13 - 59		20 - 14		10 - 9
6B4-82316-00	9 - 15	90119-08M45	14 - 25	90386-08032	11 - 22	91490-30020	17 - 14	93210-40M10	14 - 10	97095-06016	3 - 5
62E-8231X-00	9 - 6	90152-05011	11 - 19	90386-12M45	10 - 6	91609-20008	3 - 19	93210-46M16	3 - 2		8 - 5
6E3-82370-21	9 - 9	90157-05M19	18 - 4	90386-12MA2	10 - 7	91690-20010	4 - 15		20 - 8		9 - 11
62E-82371-11	9 - 5	90157-06M06	15 - 16	90386-40M08	14 - 11	91690-30008	13 - 20	93210-56M80	16 - 59		10 - 10
682-82556-00	10 - 18	90159-05007	4 - 8	90386-40M09	14 - 9	92990-06300	17 - 9		21 - 11	97095-06020	4 - 3
689-82575-04	10 - 17	90170-08009	14 - 32	90387-06M06	12 - 24	92990-06600	13 - 16	93210-57M09	16 - 58		6 - 2
689-8257Y-00	10 - 19	90170-12066	8 - 14	90387-06M13	13 - 14		13 - 48		21 - 10		8 - 8
6N7-83557-00	9 - 21	90171-08M00	13 - 60	90387-06M20	13 - 38		13 - 57	93306-00501	16 - 55		12 - 26
6B4-85520-00	8 - 3	90171-10M01	17 - 13	90387-06M24	8 - 10	92990-08600	13 - 25	93306-205A1	3 - 12		15 - 10
6B4-85530-00	9 - 3	90171-10M07	17 - 18		19 - 2		13 - 61	93310-620W5	3 - 17		16 - 60
63V-85533-00	8 - 4	90173-06009	7 - 26	90387-06M50	12 - 2		14 - 35	93315-314V8	16 - 7	97095-06025	14 - 4
	19 - 1	90179-08M06	16 - 43	90430-08020	16 - 15	92995-06600	3 - 6	93315-317U2	16 - 56		14 - 13
6B4-85540-03	9 - 1	90185-08057	14 - 19		21 - 4		4 - 4	93332-00005	16 - 12	97095-06035	7 - 24
6B4-85550-01	8 - 1	90201-08M12	14 - 16	90445-07022	15 - 25		4 - 7	93390-00029	3 - 13	97095-06045	16 - 28
6B4-85550-10	8 - 1	90201-08M13	14 - 17	90445-07M08	2 - 5		6 - 3	93420-30042	15 - 19		21 - 20

NUMERICAL INDEX
INDICE NUMERICO

PART NO. CODIGO N°	REF. NO.	PART NO. CODIGO N°	REF. NO.	PART NO. CODIGO N°	REF. NO.	PART NO. CODIGO N°	REF. NO.	PART NO. CODIGO N°	REF. NO.
97095-06095	4 - 6								
97095-08012	14 - 33								
97095-08030	11 - 9								
97095-08055	11 - 7								
97575-08535	15 - 23								
	17 - 4								
97575-08550	15 - 7								
97575-08555	14 - 26								
97780-40112	16 - 20								
97780-40520	12 - 13								
	12 - 15								
97780-50110	16 - 6								
97780-50616	1 - 8								
97803-04010	5 - 6								
97880-05012	17 - 6								
97885-06008	13 - 4								
97980-04114	5 - 15								
	20 - 19								
97980-04125	5 - 26								
98580-04006	5 - 33								
98580-04008	5 - 23								
98780-05015	2 - 8								
98980-03006	5 - 24								
99080-05600	13 - 33								
	13 - 40								
99080-09600	13 - 51								