



**PARTS  
CATALOGUE  
CATALOGO  
DE REPUESTOS**

**F150AET'12** (63P9)

**FL150AET'12** (64P9)



1L63P-200S1

( )

F150AET/FL150AET  
PARTS CATALOGUE  
©2011 by Yamaha Motor Co., Ltd.  
1st edition, October 2011  
All rights reserved.  
Any reprinting or unauthorized use  
without the written permission of  
Yamaha Motor Co., Ltd.  
is expressly prohibited.  
Printed in Japan.

F150AET/FL150AET  
CATALOGO DE REPUESTOS  
©2011 por Yamaha Motor Co., Ltd.  
1ª edición, octubre 2011  
Todos los derechos reservados.  
Toda reproducción o uso no autorizado  
sin el consentimiento escrito de  
Yamaha Motor Co., Ltd.  
quedan expresamente prohibidos  
Impreso en Japón.

# FOREWORD

This Parts Catalogue is related to the parts for the model(s) on the cover page. When you are ordering replacement parts, please refer to this Parts Catalogue and quote both part numbers and part names correctly.

1. Modifications or additions which have been made after the issue of the Parts Catalogue will be announced in the Parts News.  
It is advisable that you make the necessary corrections to the Parts Catalogue according to the Parts News.

2. Abbreviations

The following abbreviations are used in this Parts Catalogue.

“UR” Use specified parts number.

“UN” Use as many as needed.

“AP” Alternate Parts

“LM” Locally Made (Parts need to be ordered locally)

“F#” Frame No. (Applicable machine No.)

“O/S” Over Size

3. The number of components for assembly

- Parts, which are to be supplied in an assembly, are listed with a dot (.) in front of the part name as shown below.
- The numeral appearing to the right of each component part indicates the quantity of parts for each assembly unit.

PART NO.	DESCRIPTION	Q'TY	REMARKS
2F5-83310-60	FRONT FLASHER LIGHT ASSY	2	
115-83311-60	.BULB (6V-18W)	1	

4. Applicable colours of graphics are represented in the “REMARKS” as shown below.

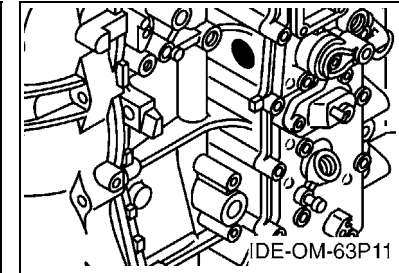
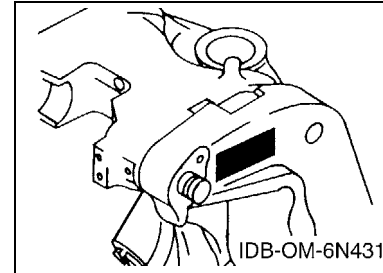
PART NO.	DESCRIPTION	Q'TY	REMARKS
2N4-24110-00-X5	FUEL TANK COMP.	2	MXR
3J1-24240-10	.GRAPHIC, FUEL TANK	1	FOR MXR

5. Note that the illustrations for reference in finding parts numbers are not to be used for assembling. When assembling, please use the applicable service manual.

6. The asterisk (\*) before a reference number indicates modified items after the first edition.

7. Applicable Serial No.

Engine Serial No.



8. Applicable Engine Starting Serial No.

Model	Serial No.	Model	Serial No.
F150A	63P-1106291	FL150A	64P-1013389

9. Applicable Colour Code

Abbreviation	Colour Name	Colour Code
DBN1	DARK BLUISH GRAY 1	008D

10. Quantity Column Information

Column No.	Name Of Q'ty Column	Applicable Model
1	63P9	F150AET
2	64P9	FL150AET

# PROLOGO

Este catálogo de repuestos corresponde a las piezas para el o los modelos que figuran en la página de portada. Al formular el pedido de repuestos, se ruega citar este catálogo y especificar correctamente el número y el nombre de las piezas.

- Las modificaciones y agregados que se hayan realizado después de la edición de este Catálogo de Repuestos, serán anunciados en las Informaciones de Recambios. Es recomendable que se hagan las correcciones necesarias en el Catálogo de Repuestos de acuerdo con las Informaciones de Recambios.

## 2. Abreviaciones

En este. Catálogo de Repuestos se emplean las siguientes abreviaciones.

“UR” Usar el número de partes especificado

“UN” Usar la cantidad necesaria

“AP” Piezas sustitutivas

“LM” Fabricación local (Hay que pedir los repuestos en las cercanías)

“F#” N° de bastidor (N° aplicable a la máquina)

“O/S” Sobredimensionado

## 3. La cantidad de componentes para el montaje

- Los componentes, suministrados como conjunto, se describen con un punto (.) que precede al nombre del parte como se indica a continuación.
- La numeración que aparece a la derecha de cada descripción indica la cantidad de partes por cada unidad de conjunto.

CODIGO N°	DESCRIPCION	CANT.	OBSERVACIONES
2F5-83310-60	ENSAMBLAJE DE LA LUZ	2	
115-83311-60	.BOMBILLA (6V-18W)	1	

## 4. Los colores de los componentes se indican como sigue en la columna de “OBSERVACIONES”.

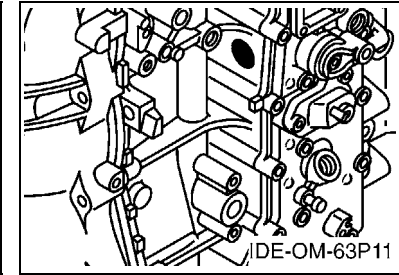
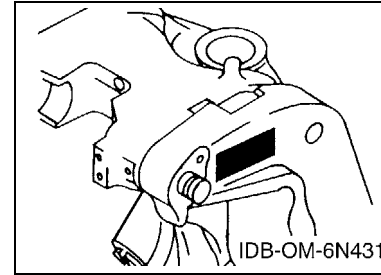
CODIGO N°	DESCRIPCION	CANT.	OBSERVACIONES
2N4-24110-00-X5	COMP. DEL TANQUE	2	MXR
3J1-24240-10	.GRAFICO, DEL TANQUE	1	PARA MXR

- Debe tenerse en cuenta que las ilustraciones sirven como guía para la búsqueda de los números de partes y no deben usarse para el montaje. Durante el montaje, se recomienda usar el manual de taller correspondiente.

- EL asterisco (\*) antes del número de referencia indica los elementos modificados después de la primera edición.

## 7. Números de serie

N° de Serie del motor



## 8. Números de serie del motor

Modelo	N° de serie	Modelo	N° de serie
F150A	63P-1106291	FL150A	64P-1013389

## 9. Códigos de color aplicables

Abreviatura	Nombre de color	Código de color
DBN1	DARK BLUISH GRAY 1	008D

## 10. Informacion para la columna de cantidades

Columna N°	Nombre de la columna de cantidades	Modelo aplicable
1	63P9	F150AET
2	64P9	FL150AET

# CONTENTS

TOP COWLING .....	1
CYLINDER & CRANKCASE 1 .....	2
CRANKSHAFT & PISTON .....	4
CYLINDER & CRANKCASE 2 .....	5
CYLINDER & CRANKCASE 3 .....	7
VALVE .....	9
INTAKE 1 .....	11
INTAKE 2 .....	12
INTAKE 3 .....	13
FUEL INJECTION PUMP 1 .....	15
FUEL INJECTION PUMP 2 .....	17
FUEL 1 .....	18
FUEL 2 .....	20
GENERATOR .....	21
ELECTRICAL 1 .....	22
ELECTRICAL 2 .....	23
ELECTRICAL 3 .....	25
STARTING MOTOR .....	27
BOTTOM COWLING .....	29
CONTROL .....	32
BRACKET 1 .....	35
BRACKET 2 .....	37
POWER TRIM & TILT ASSY 1 .....	39
POWER TRIM & TILT ASSY 2 .....	42
UPPER CASING .....	43
OIL PAN .....	45
LOWER CASING & DRIVE 1 .....	46
LOWER CASING & DRIVE 2 .....	50
LOWER CASING & DRIVE 3 .....	52
LOWER CASING & DRIVE 4 .....	56
STEERING GUIDE .....	58
REMOTE CONTROL BOX .....	59
REMOTE CONTROL ASSY 1 .....	60
REMOTE CONTROL ASSY 2 .....	63
REMOTE CONTROL ASSY 3 .....	66
METER .....	69
SWITCH & PANEL 1 .....	71
SWITCH & PANEL 2 .....	72
OPTIONAL PARTS .....	73
REPAIR KIT 1 .....	74
REPAIR KIT 2 .....	75

## INDEX

NUMERICAL INDEX .....	77
-----------------------	----

# CONTENIDO

SOPORTE SUPERIOR .....	1
CILINDRO & CARTER 1 .....	2
CIGUENAL & PISTON .....	4
CILINDRO & CARTER 2 .....	5
CILINDRO & CARTER 3 .....	7
VALVULA .....	9
ADMISION 1 .....	11
ADMISION 2 .....	12
ADMISION 3 .....	13
BOMBA DE INYECTOR 1 .....	15
BOMBA DE INYECTOR 2 .....	17
COMBUSTIBLE 1 .....	18
COMBUSTIBLE 2 .....	20
GENERADOR .....	21
EQUIPO ELECTRICO 1 .....	22
EQUIPO ELECTRICO 2 .....	23
EQUIPO ELECTRICO 3 .....	25
MOTOR DE ARRANQUE .....	27
CUBIERTA INFERIOR .....	29
CONTROL .....	32
SOPORTE 1 .....	35
SOPORTE 2 .....	37
COMPONER Y PODER VARILLA 1 .....	39
COMPONER Y PODER VARILLA 2 .....	42
FUNDA SUPERIOR .....	43
OIL PAN .....	45
IMPULSOR E INFERIOR 1 .....	46
IMPULSOR E INFERIOR 2 .....	50
IMPULSOR E INFERIOR 3 .....	52
IMPULSOR E INFERIOR 4 .....	56
DIRECCIONGUIAR .....	58
CONTROL REMOTO COMPLETO .....	59
CONTROL REMOTO COMPL 1 .....	60
CONTROL REMOTO COMPL 2 .....	63
CONTROL REMOTO COMPL 3 .....	66
MEDIDOR .....	69
PANEL DE INTERRUPTOR 1 .....	71
PANEL DE INTERRUPTOR 2 .....	72
PARTES OPCIONALES .....	73
ESTUCHE REPARATION 1 .....	74
ESTUCHE REPARATION 2 .....	75

## INDICE

INDICE NUMERICO .....	77
-----------------------	----

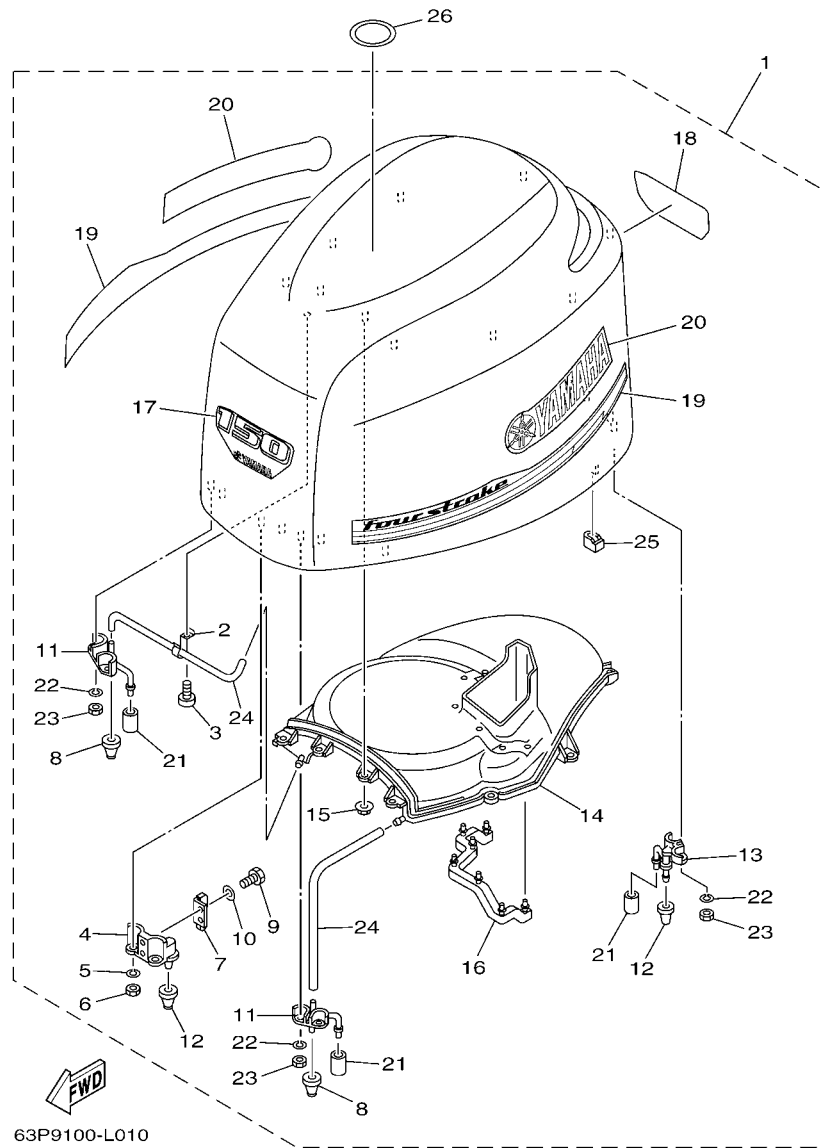
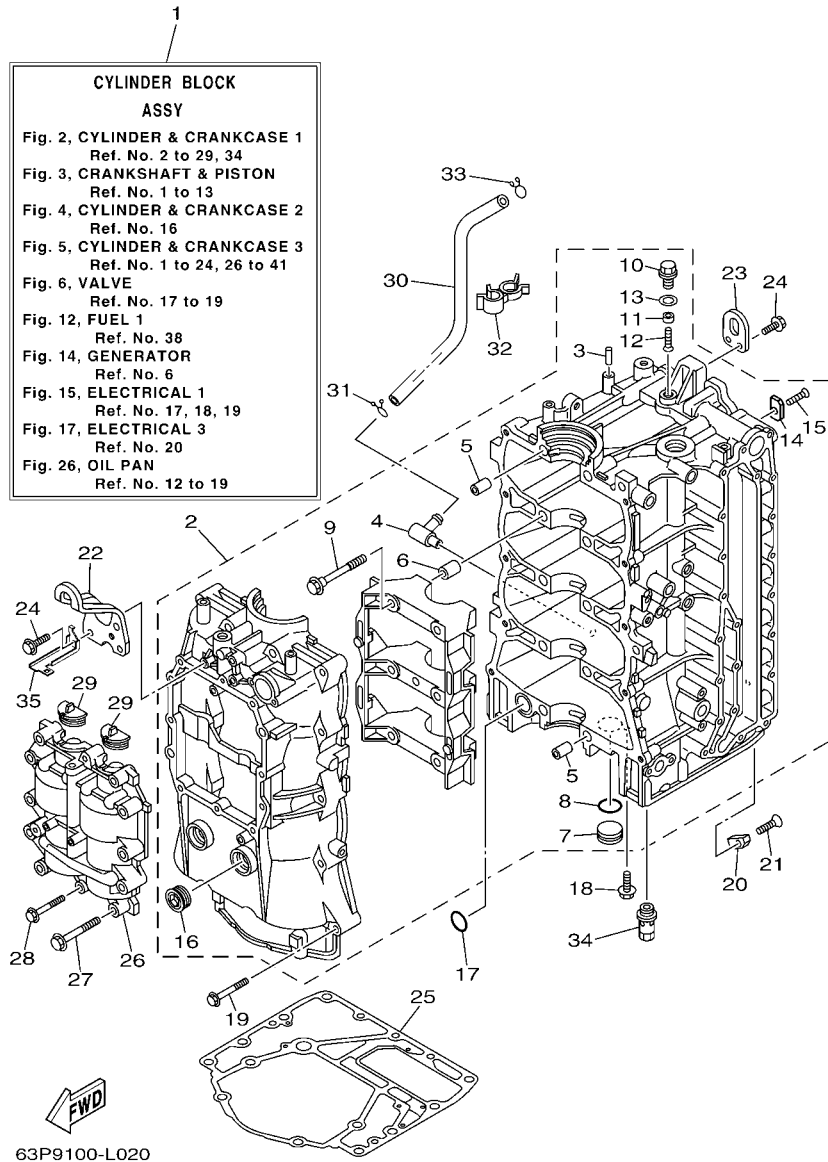


FIG. 1 TOP COWLING

SOPORTE SUPERIOR

REF. NO.	PART NO. CODIGO N°	DESCRIPTION DESCRIPCION			REMARKS OBSERVACIONES
			63P9	64P9	
1	63P-42610-40	TOP COWLING ASSY SOPORTE SUPERIOR COMPL.	1	1	
2	90465-10032	.CLAMP .BRIDA	1	1	
3	97780-50620	.SCREW, TAPPING .TORNILLO DE CABEZA DE CONO ACH	1	1	
4	63P-42647-00	.HOLDER, CLAMP BAND .MORDAZA DE ABRAZADERA	2	2	
5	92990-06100	.WASHER, SPRING .ARANDELA PLANA	4	4	
6	95380-06600	.NUT, HEXAGON .TUERCA	4	4	
7	60V-42651-01	.HOOK .GANCHO	2	2	
8	69J-42663-00	.DAMPER .AMORTIGUADOR 2	2	2	
9	97095-06016	.BOLT .PERNO	4	4	
10	92995-06600	.WASHER .ARANDELA	4	4	
11	63P-42643-01	.PLATE, CLAMP .PLACA GRAMPA	2	2	
12	68F-42663-00	.DAMPER .AMORTIGUADOR 2	4	4	
13	63P-42644-00	.PLATE, CLAMP 2 .PLACA GRAMPA 2	2	2	
14	63P-42613-00	.MOLDING, AIR DUCT .MOLDURA CONDUCTO AIRE	1	1	
15	90179-06M24	.NUT .TUERCA	10	10	
16	63P-42617-00	.DAMPER, FORM .HULE DE FORMA	1	1	
17	63P-42677-40	.GRAPHIC, FRONT .CALCAMONIA FRONTAL	1	1	
18	63P-42678-40	.GRAPHIC, REAR .CALCAMONIA TRASERA	1	1	
19	63P-W0070-20	.GRAPHIC SET .JUEGO DE EMBLEMA	1	1	
20	63P-42681-20	.MARK, COWLING .MARCA DE CUBIERTA	2	2	
21	67F-13448-00	.CAP .TAPA	4	4	
22	92990-06100	.WASHER, SPRING .ARANDELA PLANA	8	8	
23	95380-06600	.NUT, HEXAGON .TUERCA	8	8	
24	90445-11020	.HOSE (L400) .TUBO (L400)	2	2	
25	63P-42662-00	.DAMPER .AMORTIGUADOR	4	4	
26	67F-13434-20	LABEL, CAUTION ETIQUETA DE PRECAUCION	1	1	

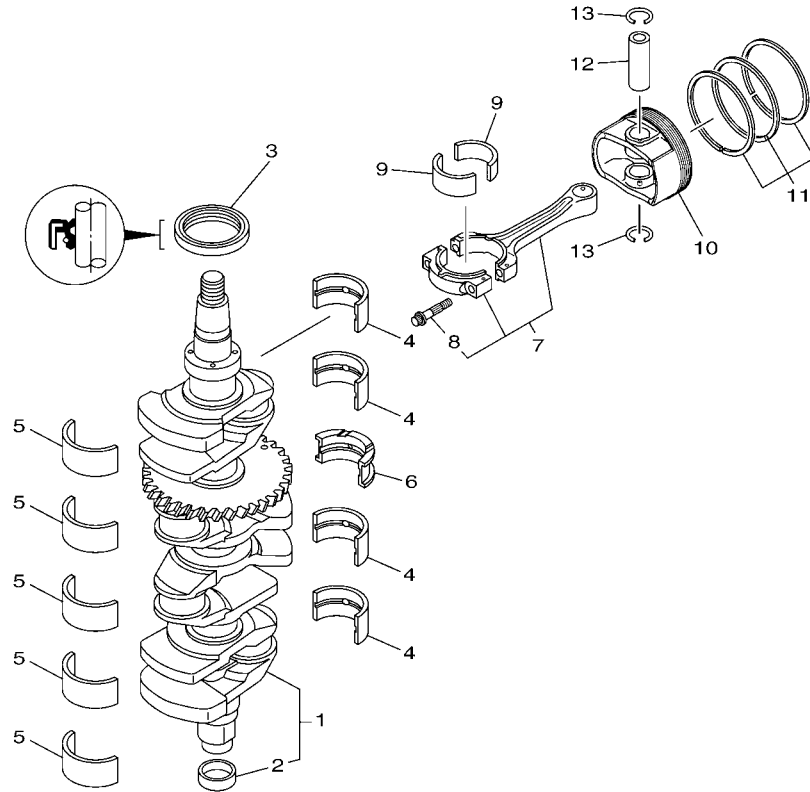


**FIG. 2 CYLINDER & CRANKCASE 1 CILINDRO & CARTER 1**

REF. NO.	PART NO. CODIGO Nº	DESCRIPTION DESCRIPCION	63P9	64P9	REMARKS OBSERVACIONES
1	63P-W009B-10-9S	CYLINDER BLOCK ASSY CILINDRO BLOQUE COMPLETO	1	1	
2	63P-W1510-03-9S	CRANKCASE ASSY CARTER COMPLETO	1	1	
3	93606-12019	.PIN, DOWEL .PASADOR DE CLAVIJA	1	1	
4	63P-11372-00	.NIPPLE, HOSE .NIPLE DE MANGUERA	1	1	
5	91814-18002	.PIN, DOWEL .PASADOR DE CLAVIJA	4	4	
6	91814-18002	.PIN, DOWEL .PASADOR DE CLAVIJA	6	6	
7	90338-25004	.PLUG .TAPON	1	1	
8	93210-25647	.O-RING .ANILLO O	1	1	
9	90105-10071	.BOLT, FLANGE .TORNILLO	10	10	
10	63P-11197-00	.PLUG, BLIND .TAPON CIEGO	1	1	
11	63P-11325-21	.ANODE .ANODO	1	1	
12	98780-05016	.SCREW, FLAT HEAD .TORNILLO CABEZA PLANA	1	1	
13	90430-14115	.GASKET .JUNTA	1	1	
14	63P-11325-11	.ANODE .ANODO	4	4	
15	90151-06M02	.SCREW, COUNTERSUNK .TORNILLO EMBUTIDO	4	4	
16	90340-27129	.PLUG, STRAIGHT SCREW .TORNILLO, DE DRENAJE	2	2	
17	93210-25552	O-RING ANILLO O	1	1	
18	90119-06M81	BOLT, WITH WASHER TORNILLO CON ARANDELA	1	1	
19	90119-08M66	BOLT, WITH WASHER TORNILLO CON ARANDELA	10	10	
20	63P-11325-01	ANODE ANODO	1	1	
21	90151-06M02	SCREW, COUNTERSUNK TORNILLO EMBUTIDO	1	1	
22	63P-11119-00	HANGER, ENGINE SOPORTE DEL MOTOR	1	1	
23	68F-11119-00	HANGER, ENGINE SOPORTE DEL MOTOR	1	1	
24	90119-06MA2	BOLT, WITH WASHER TORNILLO CON ARANDELA	5	5	
25	63P-11351-00	GASKET, CYLINDER JUNTA, DE CILINDRO	1	1	
26	63P-11500-03	BALANCER ASSY COMPENSADOR COMPLETA	1	1	
27	90119-08M66	BOLT, WITH WASHER TORNILLO CON ARANDELA	10	10	







63P9110-L030

FIG. 3 CRANKSHAFT & PISTON

CIGUENAL & PISTON

REF. NO.	PART NO. CODIGO Nº	DESCRIPTION DESCRIPCION	63P9	64P9	REMARKS OBSERVACIONES
1	63P-11410-03	CRANKSHAFT CIGUENAL	1	1	
2	6CB-11478-00	.COLLAR .COLLAR	1	1	
3	93102-60008	OIL SEAL SELLO ACEITE	1	1	
4	63P-11416-31	PLANE BEARING, CRANKSHAFT 1 COJINETE PLANO 1	4	4	UR GREEN UR GREEN
	63P-11416-41	PLANE BEARING, CRANKSHAFT 1 COJINETE PLANO 1	4	4	UR RED UR RED
	63P-11416-51	PLANE BEARING, CRANKSHAFT 1 COJINETE PLANO 1	4	4	UR YELLOW UR YELLOW
5	63P-11417-41	PLANE BEARING, CRANKSHAFT 2 COJINETE PLANO 2	5	5	UR BROWN UR BROWN
	63P-11417-51	PLANE BEARING, CRANKSHAFT 2 COJINETE PLANO 2	5	5	UR GREEN UR GREEN
	63P-11417-61	PLANE BEARING, CRANKSHAFT 2 COJINETE PLANO 2	5	5	UR RED UR RED
	63P-11417-71	PLANE BEARING, CRANKSHAFT 2 COJINETE PLANO 2	5	5	UR YELLOW UR YELLOW
	63P-11417-81	PLANE BEARING, CRANKSHAFT 2 COJINETE PLANO 2	5	5	UR BLUE UR BLUE
6	63P-11426-31	BEARING, THRUST 1 COJINETE DE EMPUJE 1	1	1	UR GREEN UR GREEN
	63P-11426-41	BEARING, THRUST 1 COJINETE DE EMPUJE 1	1	1	UR RED UR RED
	63P-11426-51	BEARING, THRUST 1 COJINETE DE EMPUJE 1	1	1	UR YELLOW UR YELLOW
7	63P-W1165-10	CONNECTING ROD ASSY BIELA COMPLETA	4	4	
8	63P-11654-10	.BOLT, CONNECTING ROD .TORNILLO DE BIELA	2	2	
9	63P-11656-30	PLANE BEARING, CONNECTING ROD COJINETE PLANO	8	8	UR GREEN UR GREEN
	63P-11656-40	PLANE BEARING, CONNECTING ROD COJINETE PLANO	8	8	UR BLUE UR BLUE
	63P-11656-50	PLANE BEARING, CONNECTING ROD COJINETE PLANO	8	8	UR RED UR RED
10	63P-11631-10-93	PISTON (STD) PISTON (NORMA)	4	4	
	63P-11635-10	PISTON (0.25MM O/S) PISTON (0.25MM O/S)	4	4	AP AP
11	63P-11603-01	PISTON RING SET (STD) JUEGO DE ANILLOS (NORMA)	4	4	
	63P-11604-00	PISTON RING SET (0.25MM O/S) JUEGO DE ANILLOS (0.25MM O/S)	4	4	AP AP
12	63P-11633-10	PIN, PISTON PASADOR, PISTON	4	4	
13	63P-11634-00	CLIP, PISTON PIN PRESILLA, BULON DE PISTON	8	8	

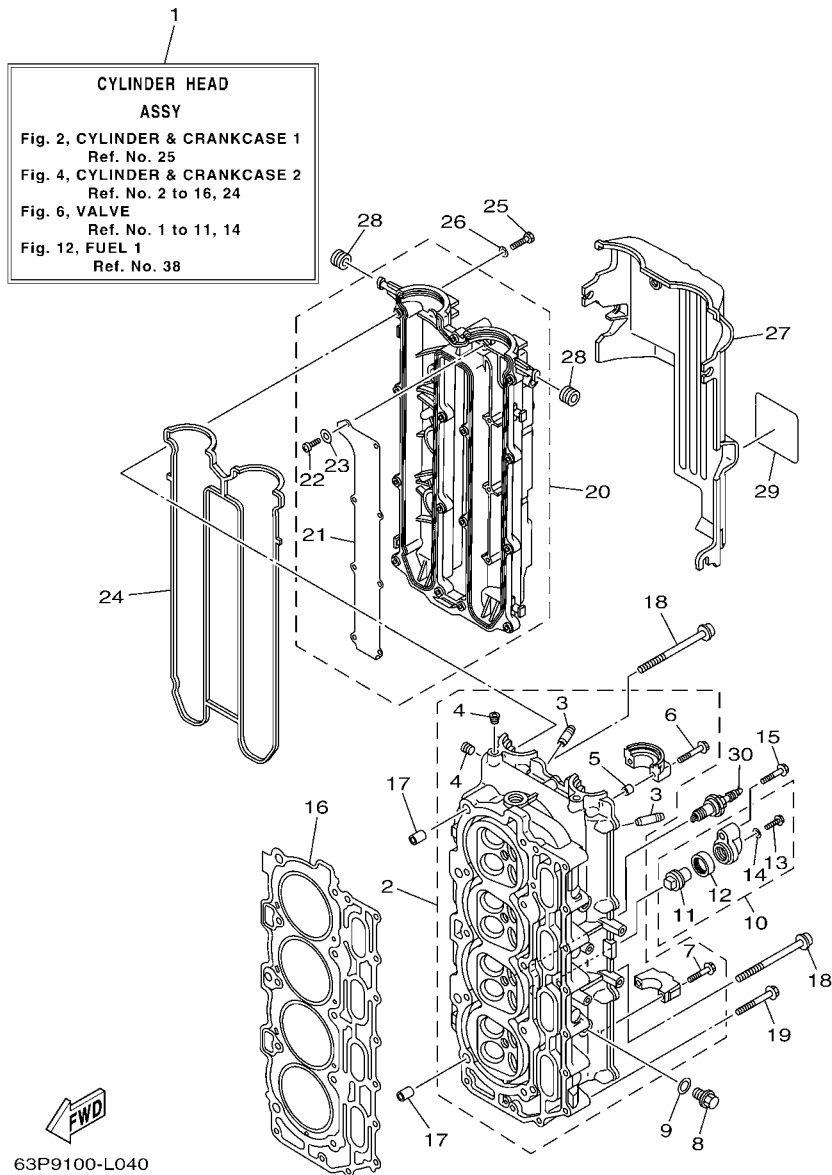
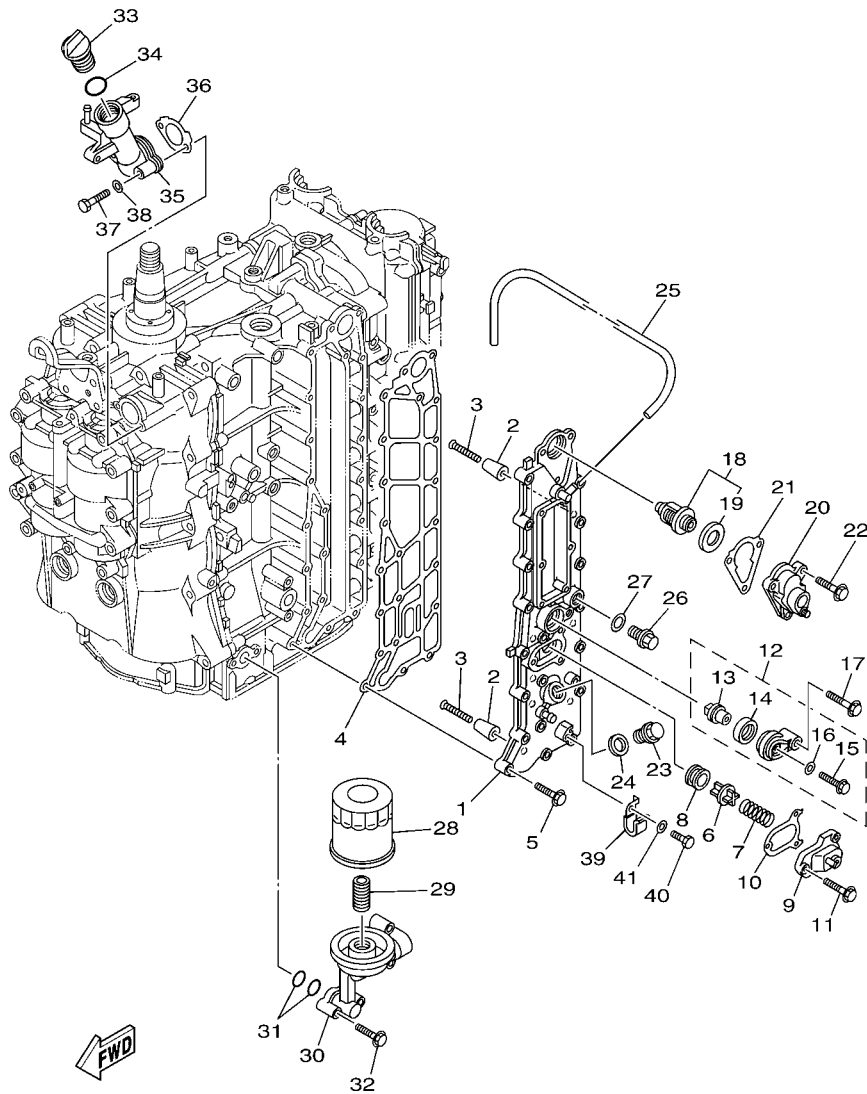


FIG. 4 CYLINDER & CRANKCASE 2 CILINDRO & CARTER 2

REF. NO.	PART NO. CODIGO Nº	DESCRIPTION DESCRIPCION	63P9	64P9	REMARKS OBSERVACIONES
1	63P-W009A-03-9S	CYLINDER HEAD ASSY CILINDRO CULATA COMPLETO	1	1	
2	63P-11110-10-9S	CYLINDER HEAD ASSY CULATA DE CILINDRO COMPLETA	1	1	
3	6S5-11133-10	.GUIDE, VALVE 1 .GUIA DE VALVULA 1	16	16	
4	90344-51019	.PLUG, TAPER SCREW .TAPON DE TORNILLO AHUSADO	3	3	
5	91809-08006	.PIN, DOWEL .PASADOR DE CLAVIJA	4	4	
6	90119-07235	.BOLT/WASHER-CAM CAPS .TORNILLO CON ARANDELA	4	4	
7	90119-07234	.BOLT, WITH WASHER .TORNILLO CON ARANDELA	16	16	
8	90340-14M06	PLUG, STRAIGHT SCREW TORNILLO, DE DRENAJE	2	2	
9	90430-14115	GASKET JUNTA	2	2	
10	69J-11301-00	ANODE COVER ASSY CONJUNTO CUBIERTA DE ANODO	2	2	
11	67F-11325-01	.ANODE .ANODO	1	1	
12	67F-11328-00	.GROMMET, ANODE .TAPON	1	1	
13	90105-06M07	.BOLT, FLANGE .TORNILLO	1	1	
14	90430-06M03	.GASKET JUNTA	1	1	
15	97575-08540	BOLT, WITH WASHER PERNO CON ARANDELA	2	2	
16	63P-11181-00	GASKET, CYLINDER HEAD 1 JUNTA, DE CULATA 1	1	1	
17	99530-14016	PIN, DOWEL PASADOR, DE ESPIGA	2	2	
18	90155-10006	SCREW, FLAT FILLISTER TORNILLO CABEZA PLANA RAN.	10	10	
19	90119-08M91	BOLT, WITH WASHER TORNILLO CON ARANDELA	10	10	
20	63P-11191-00-9S	COVER, CYLINDER HEAD 1 TAPA CULATA DE CILINDRO 1	1	1	
21	63P-11135-00	.PLATE, BREATHER 3 .PLACA RESPIRADERO 3	1	1	
22	98507-04008	.SCREW, PAN HEAD .TORNILLO DE CABEZA CON PLANA	8	8	
23	92907-04600	.WASHER .ARANDELA	8	8	
24	63P-11193-00	GASKET, HEAD COVER 1 EMPAQUE	1	1	
25	97095-06030	BOLT PERNO	13	13	
26	92995-06600	WASHER ARANDELA	13	13	
27	63P-11192-01	COVER, CYLINDER HEAD 2 TAPA CULATA DE CILINDRO 2	1	1	



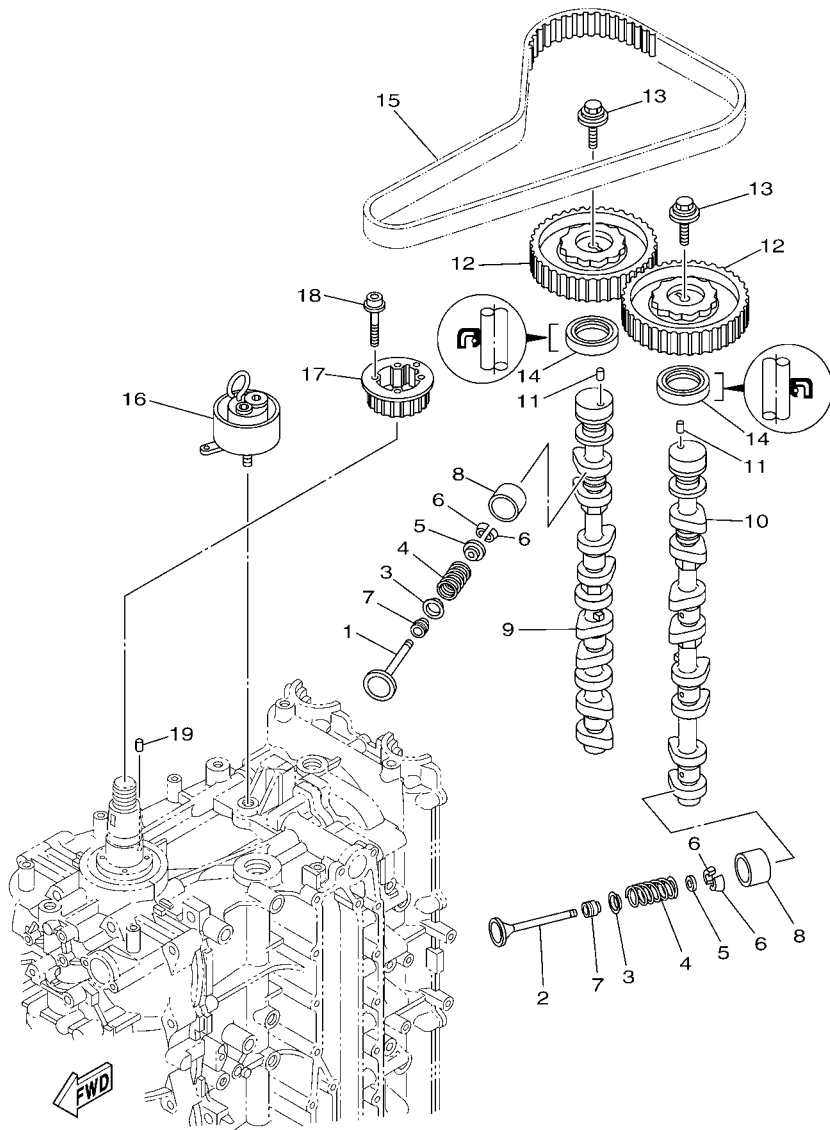


63P7100-J050

FIG. 5 CYLINDER & CRANKCASE 3 CILINDRO & CARTER 3

REF. NO.	PART NO. CODIGO Nº	DESCRIPTION DESCRIPCION	63P9	64P9	REMARKS OBSERVACIONES
1	63P-41113-03-9S	OUTER COVER, EXHAUST CUBOERTA EXTERIOR DE ESCAPE	1	1	
2	68T-11325-00	ANODE ANODO	8	8	
3	90151-05M05	SCREW, COUNTERSUNK TORNILLO EMBUTIDO	8	8	
4	63P-41114-A2	GASKET, EXHAUST OUTER COVER EMPAQUE	1	1	
5	90119-06MA4	BOLT, WITH WASHER TORNILLO CON ARANDELA	19	19	
6	6G5-12416-00	VALVE, PRESSURE CONTROL VALVULA DE CONTROL DE PRESION	1	1	
7	90501-16M11	SPRING, COMPRESSION RESORTE DE COMPRESION	1	1	
8	90480-20M05	GROMMET TAPON	1	1	
9	67F-1246A-01-9S	COVER 1 CUBIERTA 1	1	1	
10	67F-12435-A0	GASKET EMPAQUE	1	1	
11	90119-06MA2	BOLT, WITH WASHER TORNILLO CON ARANDELA	3	3	
12	69J-11301-00	ANODE COVER ASSY CONJUNTO CUBIERTA DE ANODO	1	1	
13	67F-11325-01	.ANODE .ANODO	1	1	
14	67F-11328-00	.GROMMET, ANODE .TAPON	1	1	
15	90105-06M07	.BOLT, FLANGE .TORNILLO	1	1	
16	90430-06M03	.GASKET .JUNTA	1	1	
17	97575-08540	BOLT, WITH WASHER PERNO CON ARANDELA	1	1	
18	67F-12411-01	THERMOSTAT TERMOSTAT	1	1	
19	67F-12412-00	.SEAL, THERMOSTAT .SELLO TERMOSTATO	1	1	
20	63P-1240H-01-9S	COVER ASSEMBLY CUBIERTA COPL.	1	1	
21	63P-12414-00	GASKET, COVER EMPAQUE	1	1	
22	90119-06MA4	BOLT, WITH WASHER TORNILLO CON ARANDELA	3	3	
23	90340-18M09	PLUG, STRAIGHT SCREW TORNILLO, DE DRENAJE	1	1	
24	90430-18130	GASKET JUNTA	1	1	
25	90445-10027	HOSE (L670) TUBO (L670)	1	1	
26	90340-14M06	PLUG, STRAIGHT SCREW TORNILLO, DE DRENAJE	1	1	
27	90430-14115	GASKET JUNTA	1	1	



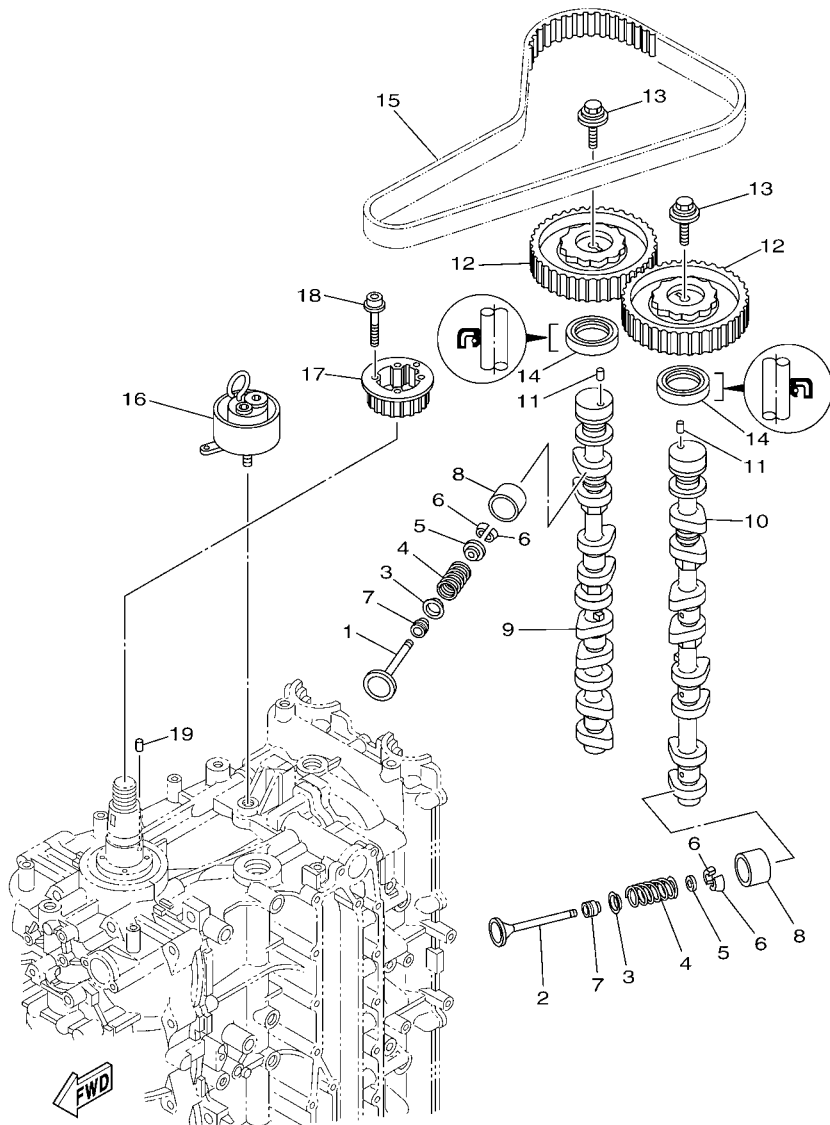


63P9110-L060

FIG. 6 VALVE

VALVULA

REF. NO.	PART NO. CODIGO Nº	DESCRIPTION DESCRIPCION	63P9	64P9	REMARKS OBSERVACIONES
1	63P-12111-00	VALVE, INTAKE VALVULA DE ADMISION	8	8	
2	63P-12121-00	VALVE, EXHAUST VALVULA DE ESCAPE	8	8	
3	K0F-A3743-00	SEAT, VALVE SPRING ASIENTO RESORTE DE VALVULA	16	16	
4	6CB-12113-00	SPRING, VALVE INNER RESORTE VALVULA INTERNA	16	16	
5	K0F-A3741-00	RETAINER, VALVE SPRING RETEN RESORTE DE VALVULA	16	16	
6	K0F-A3742-00	LOCK, VALVE SPRING RETAINER SEGURO DE VALVULA	32	32	
7	51Y-12119-00	SEAL, VALVE STEM SELLO DE ACEITE VALVULA	16	16	
8	K0F-A3751-00	LIFTER, VALVE (000) LEVANTADOR VALVULA (000)	16	16	UR
	K0F-A3751-10	LIFTER, VALVE (025) LEVANTADOR VALVULA (025)	16	16	UR
	K0F-A3751-20	LIFTER, VALVE (050) LEVANTADOR VALVULA (050)	16	16	UR
	K0F-A3751-30	LIFTER, VALVE (075) LEVANTADOR DE VALVULA (075)	16	16	UR
	K0F-A3751-40	LIFTER, VALVE (100) LEVANTADOR DE VALVULA (100)	16	16	UR
	K0F-A3751-50	LIFTER, VALVE (122) LEVANTADOR DE VALVULA (122)	16	16	UR
	K0F-A3751-60	LIFTER, VALVE (142) LEVANTADOR DE VALVULA (142)	16	16	UR
	K0F-A3751-70	LIFTER, VALVE (162) LEVANTADOR DE VALVULA (162)	16	16	UR
	K0F-A3751-80	LIFTER, VALVE (182) LEVANTADOR DE VALVULA (182)	16	16	UR
	K0F-A3751-90	LIFTER, VALVE (202) LEVANTADOR DE VALVULA (202)	16	16	UR
	K0F-A3751-A0	LIFTER, VALVE (222) LEVANTADOR VALVULA (222)	16	16	UR
	K0F-A3751-B0	LIFTER, VALVE (242) LEVANTADOR VALVULA (242)	16	16	UR
	K0F-A3751-C0	LIFTER, VALVE (262) LEVANTADOR VALVULA (262)	16	16	UR
	K0F-A3751-D0	LIFTER, VALVE (282) LEVANTADOR VALVULA (282)	16	16	UR
	K0F-A3751-E0	LIFTER, VALVE (302) LEVANTADOR VALVULA (302)	16	16	UR
	K0F-A3751-F0	LIFTER, VALVE (322) LEVANTADOR VALVULA (322)	16	16	UR
	K0F-A3751-G0	LIFTER, VALVE (342) LEVANTADOR VALVULA (342)	16	16	UR
	K0F-A3751-H0	LIFTER, VALVE (362) LEVANTADOR VALVULA (362)	16	16	UR
	K0F-A3751-J0	LIFTER, VALVE (382) LEVANTADOR VALVULA (382)	16	16	UR
	K0F-A3751-K0	LIFTER, VALVE (402) LEVANTADOR VALVULA (402)	16	16	UR



63P9110-L060

FIG. 6 VALVE

VALVULA

REF. NO.	PART NO. CODIGO Nº	DESCRIPTION DESCRIPCION	63P9	64P9		REMARKS OBSERVACIONES
8	K0F-A3751-L0	LIFTER, VALVE (422) LEVANTADOR VALVULA (422)	16	16		UR UR
	K0F-A3751-M0	LIFTER, VALVE (442) LEVANTADOR VALVULA (442)	16	16		UR UR
	K0F-A3751-N0	LIFTER, VALVE (462) LEVANTADOR VALVULA (462)	16	16		UR UR
	K0F-A3751-P0	LIFTER, VALVE (482) LEVANTADOR VALVULA (482)	16	16		UR UR
	K0F-A3751-R0	LIFTER, VALVE (502) LEVANTADOR VALVULA (502)	16	16		UR UR
	K0F-A3751-S0	LIFTER, VALVE (522) LEVANTADOR VALVULA (522)	16	16		UR UR
	K0F-A3751-T0	LIFTER, VALVE (542) LEVANTADOR VALVULA (542)	16	16		UR UR
	K0F-A3753-00	LIFTER, VALVE (562) LEVANTADOR VALVULA (562)	16	16		UR UR
	K0F-A3753-10	LIFTER, VALVE (582) LEVANTADOR VALVULA (582)	16	16		UR UR
	K0F-A3753-20	LIFTER, VALVE (602) LEVANTADOR VALVULA (602)	16	16		UR UR
	K0F-A3753-30	LIFTER, VALVE (625) LEVANTADOR VALVULA (625)	16	16		UR UR
	K0F-A3753-40	LIFTER, VALVE (650) LEVANTADOR VALVULA (650)	16	16		UR UR
	K0F-A3753-50	LIFTER, VALVE (675) LEVANTADOR VALVULA (675)	16	16		UR UR
	K0F-A3753-60	LIFTER, VALVE (700) LEVANTADOR VALVULA (700)	16	16		UR UR
	K0F-A3753-70	LIFTER, VALVE (725) LEVANTADOR VALVULA (725)	16	16		UR UR
9	63P-12171-10	CAMSHAFT 1 ARBOL DE LEVAS 1	1	1		
10	63P-12181-10	CAMSHAFT 2 ARBOL DE LEVAS 2	1	1		
11	93605-10108	PIN, DOWEL PASADOR DE CLAVIJA	2	2		
12	63P-11537-00	GEAR, DRIVEN ENGRANAJE TRACCION	2	2		
13	90119-10050	BOLT, WITH WASHER TORNILLO CON ARANDELA	2	2		
14	93102-38008	OIL SEAL SELLO ACEITE	2	2		
15	63P-46241-00	BELT CORREA	1	1		
16	63P-11590-01	TENSIONER ASSY TENSOR COMPLET	1	1		
17	63P-11536-01	GEAR, DRIVE ENGRANAJE TRACCION	1	1		
18	90110-05020	BOLT, HEXAGON SOCKET HEAD TORNILLO ALLEN	4	4		
19	93605-17002	PIN, DOWEL PASADOR DE CLAVIJA	1	1		



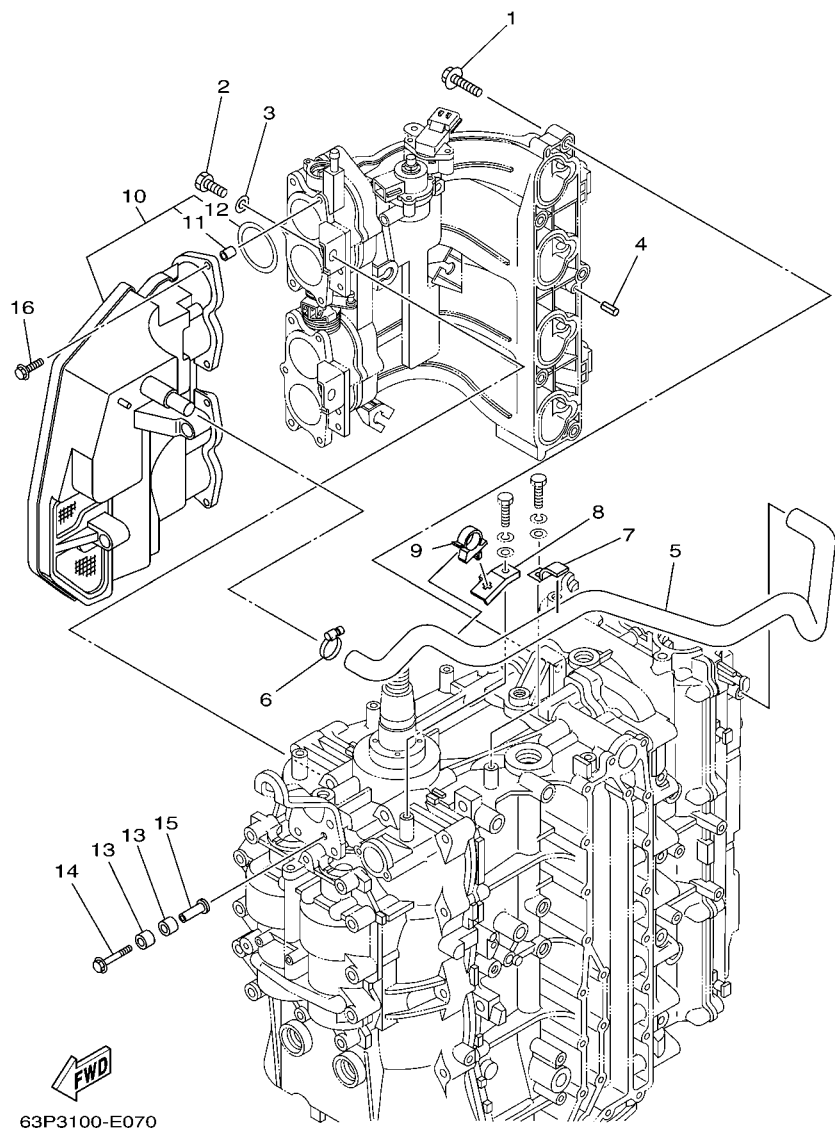


FIG. 7 INTAKE 1

ADMISION 1

REF. NO.	PART NO. CODIGO Nº	DESCRIPTION DESCRIPCION	63P9	64P9		REMARKS OBSERVACIONES
1	97575-08540	BOLT, WITH WASHER PERNO CON ARANDELA	5	5		
2	97013-08020	BOLT PERNO	2	2		
3	92903-08600	WASHER, PLATE RONDANA SENCILLA	2	2		
4	91690-50014	PIN, SPRING PASADOR DE RESORTE	2	2		
5	63P-15373-00	PIPE, BREATHER MANGUELA DE RESPIRADERO	1	1		
6	90450-22M14	HOSE CLAMP ASSY BRIDA, MANGUERA	1	1		
7	90462-10023	CLAMP BRIDA	1	1		
8	63P-15378-00	HOLDER SOPORTE	1	1		
9	90464-20006	CLAMP BRIDA	1	1		
10	63P-14440-00	SILENCER ASSY, INTAKE SILENCIADOR COMPL DE ADMISION	1	1		
11	63P-14449-00	.COLLAR .COLLAR	6	6		
12	63P-14457-00	.SEAL .SELLO	4	4		
13	90386-08001	BUSH BUJE	4	4		
14	90119-06076	BOLT, WITH WASHER TORNILLO CON ARANDELA	2	2		
15	90387-06038	COLLAR ESPACIADOR	2	2		
16	90119-06M82	BOLT, WITH WASHER TORNILLO CON ARANDELA	6	6		

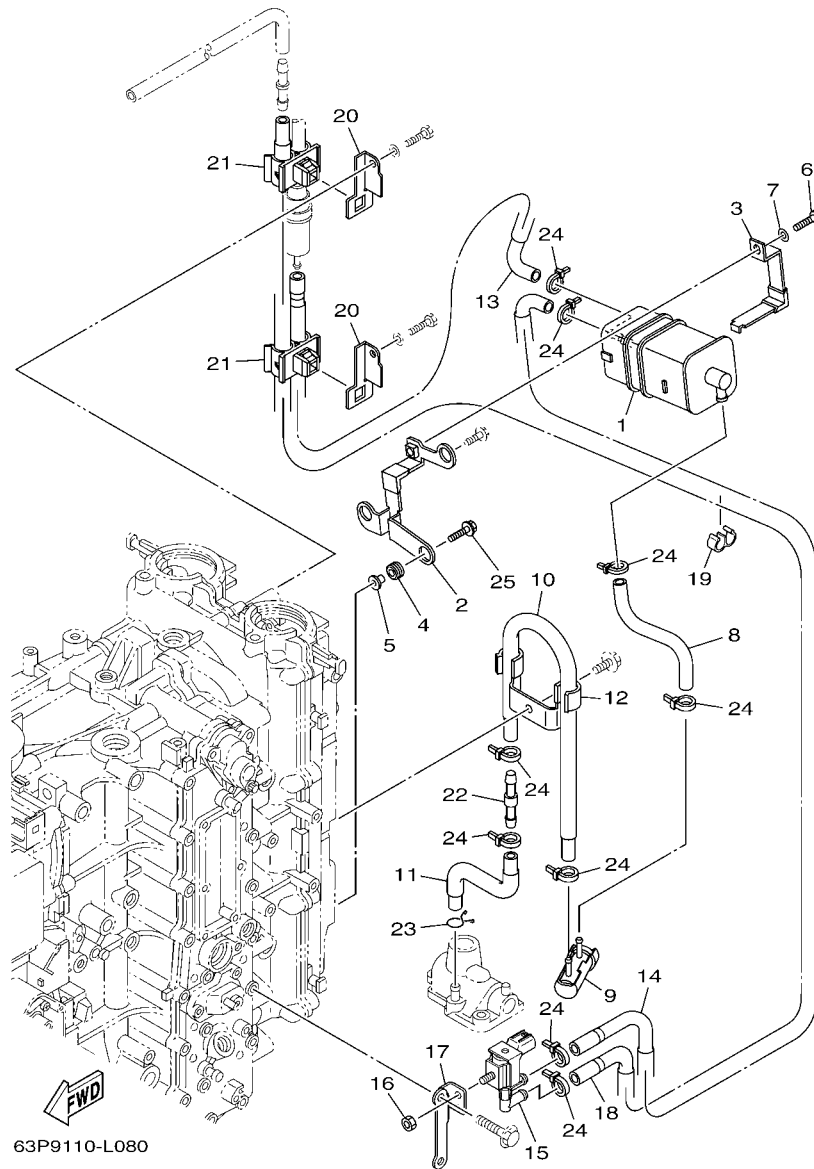


FIG. 8 INTAKE 2

ADMISION 2

REF. NO.	PART NO. CODIGO N°	DESCRIPTION DESCRIPCION	63P9	64P9	REMARKS OBSERVACIONES
1	6P2-24170-00	CANISTER ASSY FRANJA DE DEPOSITO DE COMBUST.	1	1	
2	63P-2134X-00	BRACKET, CANISTER SOPORTE	1	1	
3	63P-2419A-01	HOLDER SOSTEN	1	1	
4	90480-10M23	GROMMET TAPON	3	3	
5	90387-06M60	COLLAR ESPACIADOR	3	3	
6	97095-06016	BOLT PERNO	1	1	
7	92995-06600	WASHER ARANDELA	1	1	
8	64P-24313-00	PIPE 3 TUBO 3	1	1	
9	69J-24502-00	FILTER, FUEL FILTRO	1	1	
10	64P-24312-00	PIPE 2 TUBO 2	1	1	
11	64P-24311-00	PIPE, FUEL 1 TUBO DE COMBUSTIBLE 1	1	1	
12	63P-24367-01	CLAMP, FUEL PIPE 2 GRAMPA DE TUBO DE COMBUST.2	1	1	
13	64P-24315-00	PIPE 5 TUBO DE DESAGUE	1	1	
14	64P-24316-00	PIPE 6 TUBO 6	1	1	
15	6C5-86120-00	SOLENOID VALVE ASSY VALVULA SOLENOIDE CONJ.	1	1	
16	95380-06600	NUT, HEXAGON TUERCA	1	1	
17	63P-81845-10	PLATE PLACA	1	1	
18	64P-24314-10	PIPE 4 TUBO 4	1	1	
19	90464-09M31	CLAMP BRIDA	1	1	
20	63P-24364-01	STAY SOPORTE	2	2	
21	90464-11012	CLAMP BRIDA	2	2	
22	6E5-24379-00	PIPE, JOINT 4 TUBO DE UNION 4	1	1	
23	90467-09M09	CLIP PRESILLA	1	1	
24	90465-11M10	CLAMP BRIDA	9	9	
25	90119-06135	BOLT, WITH WASHER TORNILLO CON ARANDELA	2	2	

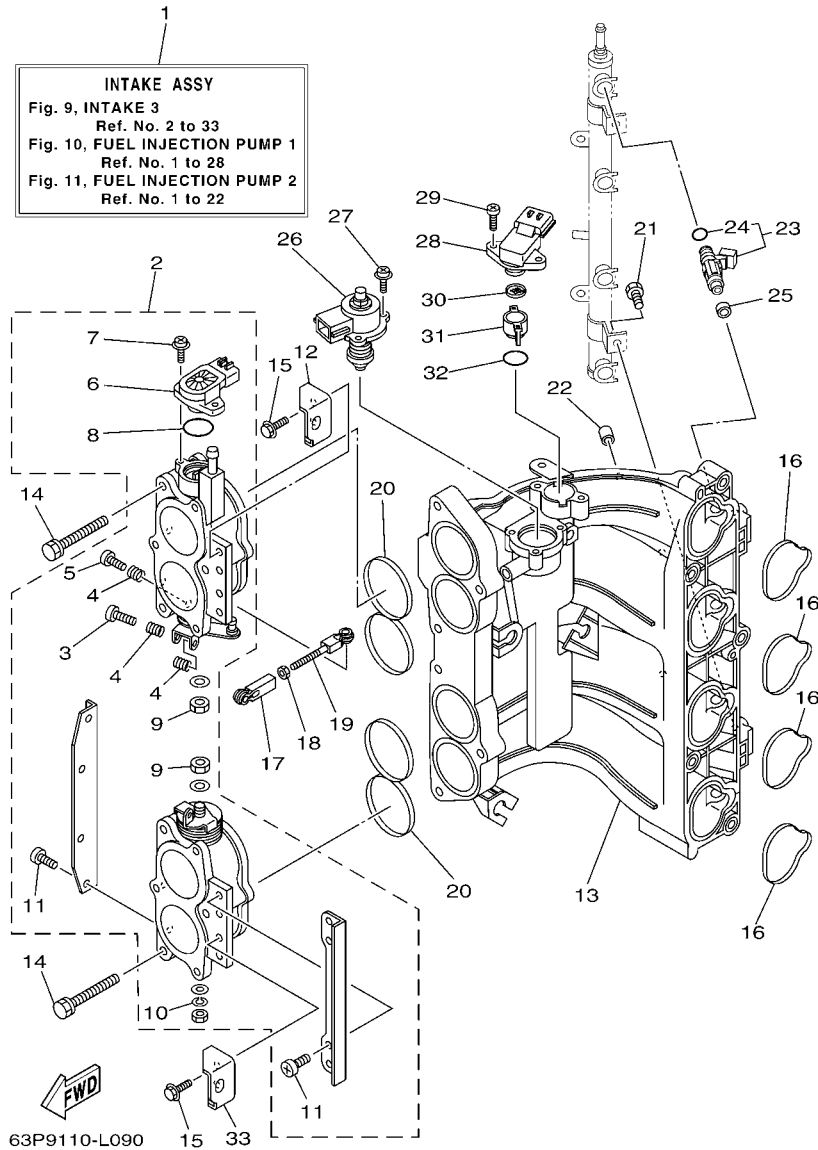


FIG. 9 INTAKE 3

ADMISION 3

REF. NO.	PART NO. CODIGO Nº	DESCRIPTION DESCRIPCION	63P9	64P9	REMARKS OBSERVACIONES
1	63P-14200-41	INTAKE ASSY ADMISION COMPL.	1	1	FOR CAR FOR CAR
	63P-14200-32	INTAKE ASSY ADMISION COMPL.	1	1	FOR BRA FOR BRA
2	63P-13751-01	BODY, THROTTLE 1 CAJA 1	1	1	FOR CAR FOR CAR
	63P-13751-11	BODY, THROTTLE 1 CAJA 1	1	1	FOR BRA FOR BRA
3	69J-14321-00	.SCREW, THROTTLE .TORNILLO DE OBTURADOR	1	1	
4	68V-14331-00	.SPRING, THROTTLE VALVE .RESORTE VALVULA ACELERADOR	3	3	
5	68V-14323-00	.SCREW, AIR ADJUSTING .TORNILLO DE AJUSTE DE AIRE	1	1	
6	6S1-85885-00	.THROTTLE SENSOR ASSY .TERMICA SENSORIO	1	1	
7	68V-81145-01	.SCREW 1 .TORNILLO 1	2	2	
8	68V-8182L-00	.O-RING 1 .ANILLO EN O	1	1	
9	3CF-14594-00	.NUT .TUERCA	2	2	
10	68V-14356-00	.WASHER, SPRING .ARANDELA DE RESORTE	1	1	
11	68V-14565-00	.SCREW .TORNILLO	8	8	
12	63P-14291-00	BRACKET 1 SOPORTE 1	1	1	
13	63P-13641-00	MANIFOLD, INTAKE 1 CONECTOR DE ADMISION 1	1	1	
14	63P-14496-00	BOLT PERNO	6	6	
15	97595-06516	BOLT, WITH WASHER PERNO CON ARANDELA	4	4	
16	63P-13645-00	GASKET, MANIFOLD 1 EMPAQUE	4	4	
17	6H4-41237-00	JOINT, LINK CONECTOR	1	1	
18	95380-05700	NUT TUERCA	1	1	
19	682-41238-01	JOINT, LINK CONECTOR	1	1	
20	63P-13557-00	GASKET EMPAQUE	2	2	
21	63P-14446-00	BOLT PERNO	2	2	
22	63P-13643-00	COVER, MANIFOLD CUBIERTA DE COLECTOR	4	4	
23	63P-13761-01	INJECTOR INYECTOR	4	4	
24	68V-1416A-00	.O-RING .ANILLO O	1	1	
25	68V-13766-00	RUBBER, INJECTOR ANILLO PROTECTOR	4	4	FOR CAR FOR CAR

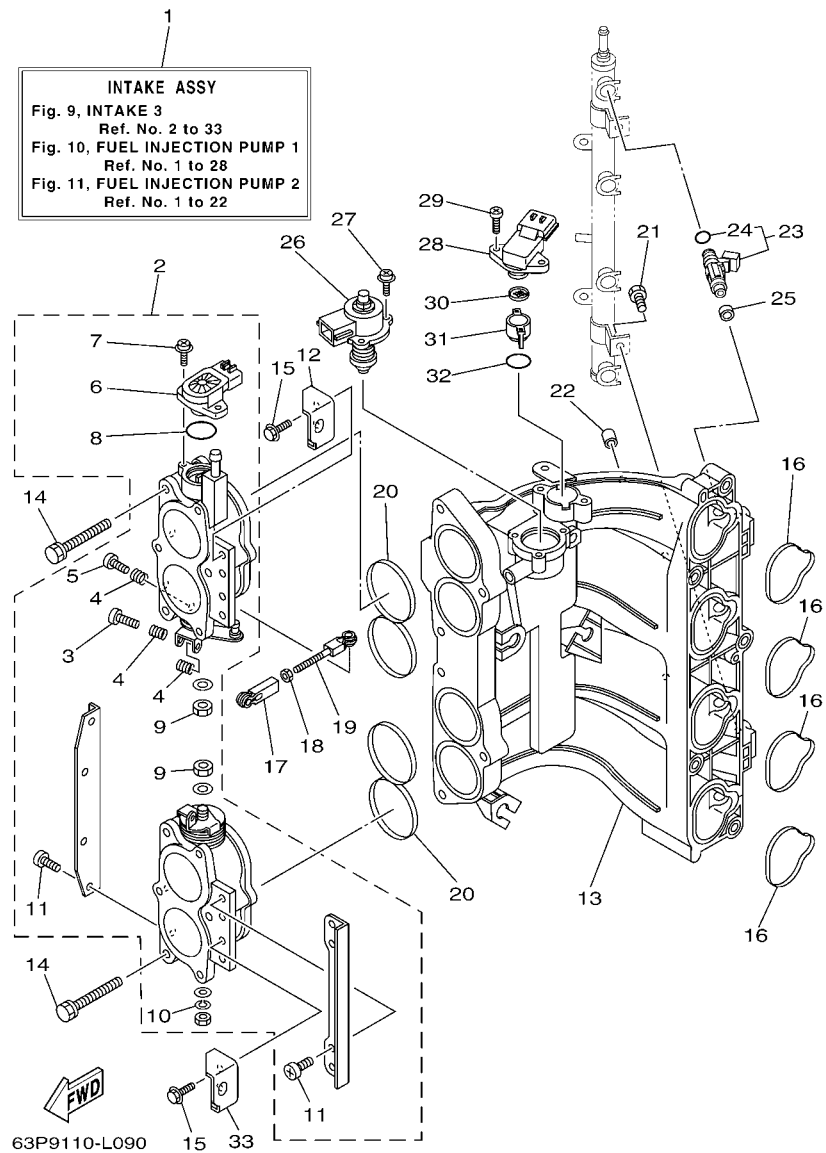
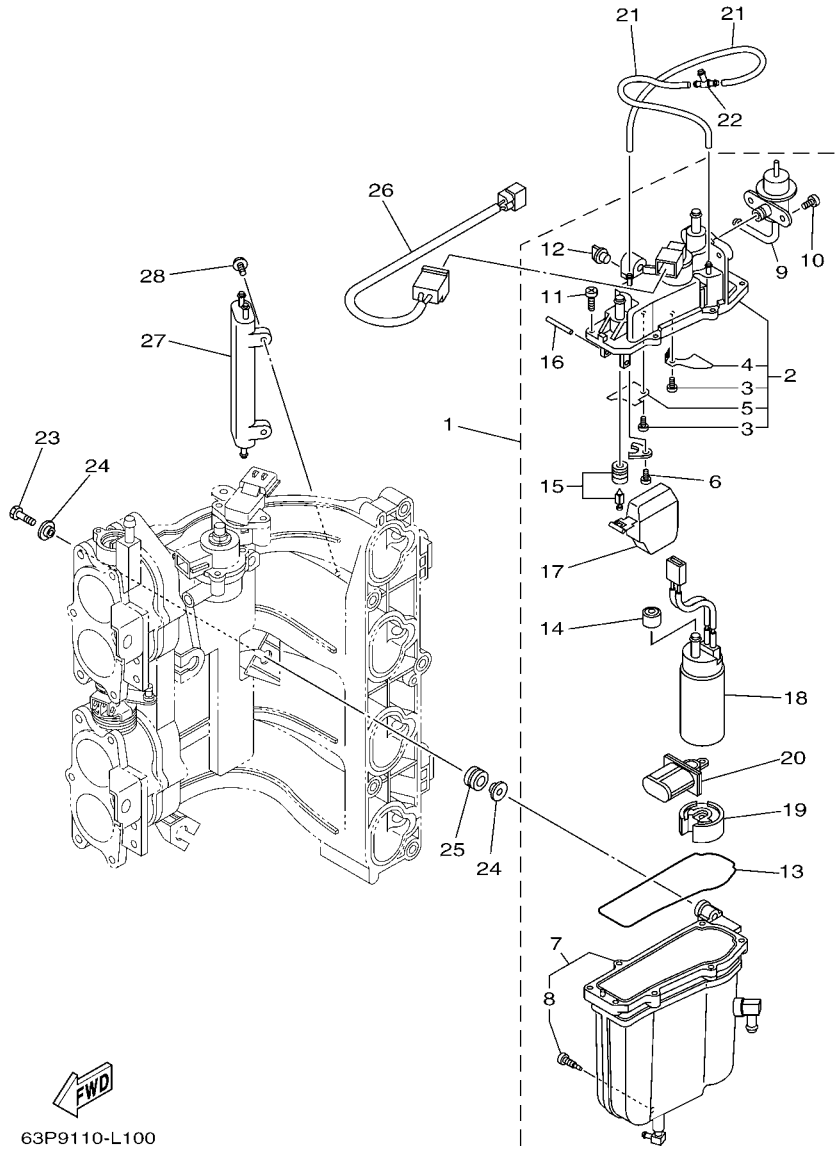


FIG. 9 INTAKE 3

ADMISION 3

REF. NO.	PART NO. CODIGO Nº	DESCRIPTION DESCRIPCION	63P9	64P9	REMARKS OBSERVACIONES
25	8FP-13556-00	RUBBER, INJECTOR ANILLO PROTECTOR	4	4	FOR BRA FOR BRA
26	63P-1312A-01	VALVE, CONTROL EMBLEMA, YAMAHA	1	1	
27	68V-81146-01	SCREW 2 TORNILLO 2	3	3	
28	63P-82380-00	SENSOR, PRESSURE SENSOR DE PRESION	1	1	
29	68V-81147-00	SCREW 3 TORNILLO 3	2	2	
30	63P-13905-00	FILTER COMP. FILTRO COMPLETO	1	1	
31	63P-13898-00	HOLDER SOSTEN	1	1	
32	63P-13769-00	O-RING ANILLO O	1	1	
33	63P-14292-00	BRACKET 2 SOPORTE 2	1	1	

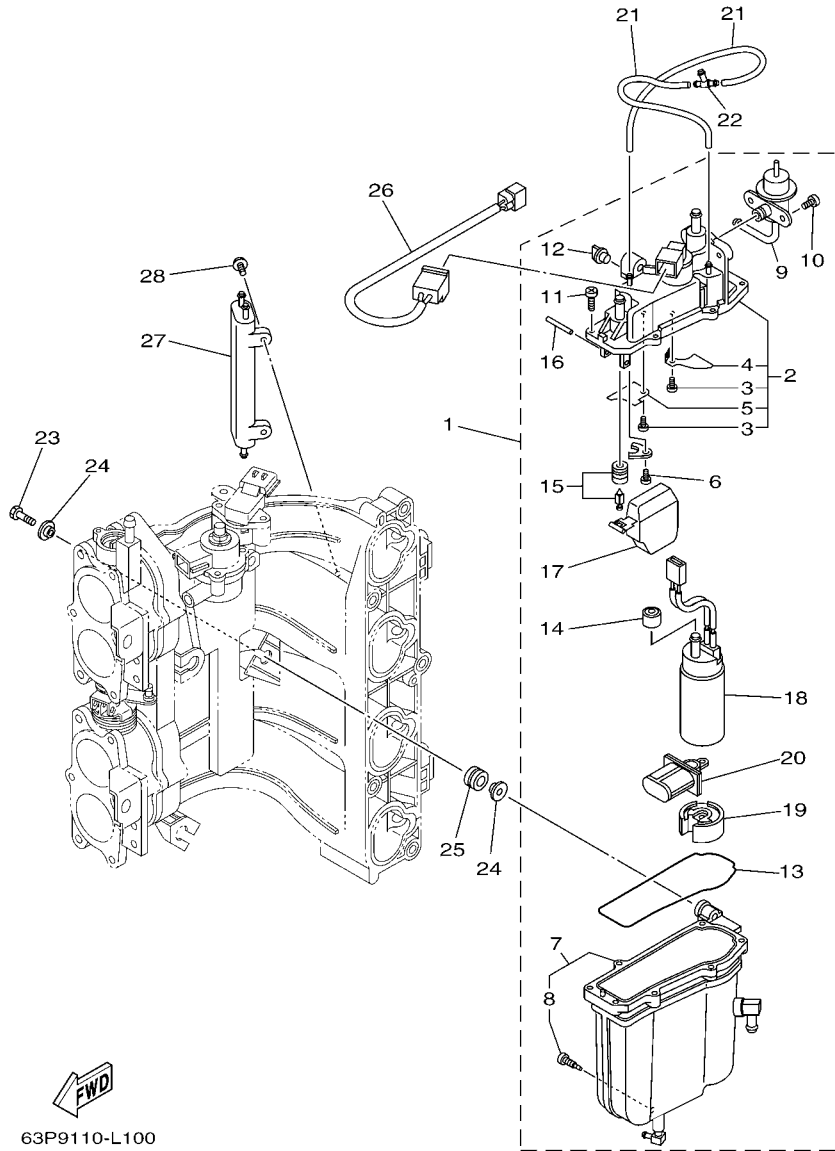


63P9110-L100

FIG. 10 FUEL INJECTION PUMP 1

BOMBA DE INYECTOR 1

REF. NO.	PART NO. CODIGO Nº	DESCRIPTION DESCRIPCION	63P9	64P9	REMARKS OBSERVACIONES
1	63P-14180-02	FLOAT CHAMBER ASSY CAMARA DE BOIA COMPLETE	1	1	FOR CAR
	63P-14180-12	FLOAT CHAMBER ASSY CAMARA DE BOIA COMPLETE	1	1	FOR BRA
2	63P-14182-00	.COVER, FLOAT CHAMBER .TAPA DE CAMARA DE BOIA	1	1	FOR CAR
	63P-14182-10	.COVER, FLOAT CHAMBER .TAPA DE CAMARA DE BOIA	1	1	FOR BRA
3	4SV-24453-00	..SCREW ..TORNILLO	2	2	FOR CAR
	69J-24453-00	..SCREW ..TORNILLO	2	2	FOR BRA
4	63P-2411R-00	..PLATE 1 ..PLACA 1	1	1	
5	63P-2411T-00	..PLATE 2 ..PLACA 2	1	1	
6	4SV-24453-00	.SCREW .TORNILLO	1	1	FOR CAR
	69J-24453-00	.SCREW .TORNILLO	1	1	FOR BRA
7	63P-14181-00	.BODY, FLOAT CHAMBER 1 .CUERPO DE CAMARA DE BOIA	1	1	FOR CAR
	63P-14181-10	.BODY, FLOAT CHAMBER 1 .CUERPO DE CAMARA DE BOIA	1	1	FOR BRA
8	63P-14191-00	..PLUG, DRAIN ..TORNILLO, DE DRENAJE	1	1	
9	63P-13906-00	.REGULATOR, PRESSURE .REGULADOR	1	1	
10	63P-14565-00	.SCREW .TORNILLO	2	2	
11	63P-14567-00	.SCREW .TORNILLO	7	7	
12	69J-14225-01	.CAP .TAPA	1	1	
13	63P-14984-00	.GASKET, FLOAT CHAMBER .EMPAQUE CAMARA DE BOIA	1	1	FOR CAR
	63P-14984-10	.GASKET, FLOAT CHAMBER .EMPAQUE CAMARA DE BOIA	1	1	FOR BRA
14	68V-13781-10	.DAMPER, PUMP .AMORTIGUADOR DE BOMBA	1	1	
15	63P-14546-00	.VALVE, NEEDLE .VALVULA DE AGUJA	1	1	FOR CAR
	63P-14546-10	.VALVE, NEEDLE .VALVULA DE AGUJA	1	1	FOR BRA
16	68V-14386-00	.PIN, FLOAT .PASADOR DE BOIA	1	1	
17	63P-14985-00	.FLOAT .BOIA	1	1	
18	63P-13907-03	.FUEL PUMP COMP. .BOMBA DE COMBUSTIBLE COMPLETE	1	1	FOR CAR
	63P-13907-12	.FUEL PUMP COMP. .BOMBA DE COMBUSTIBLE COMPLETE	1	1	FOR BRA
19	63P-13784-00	.COVER, PUMP .CUBIERTA DE BOMBA	1	1	FOR CAR



63P9110-L100

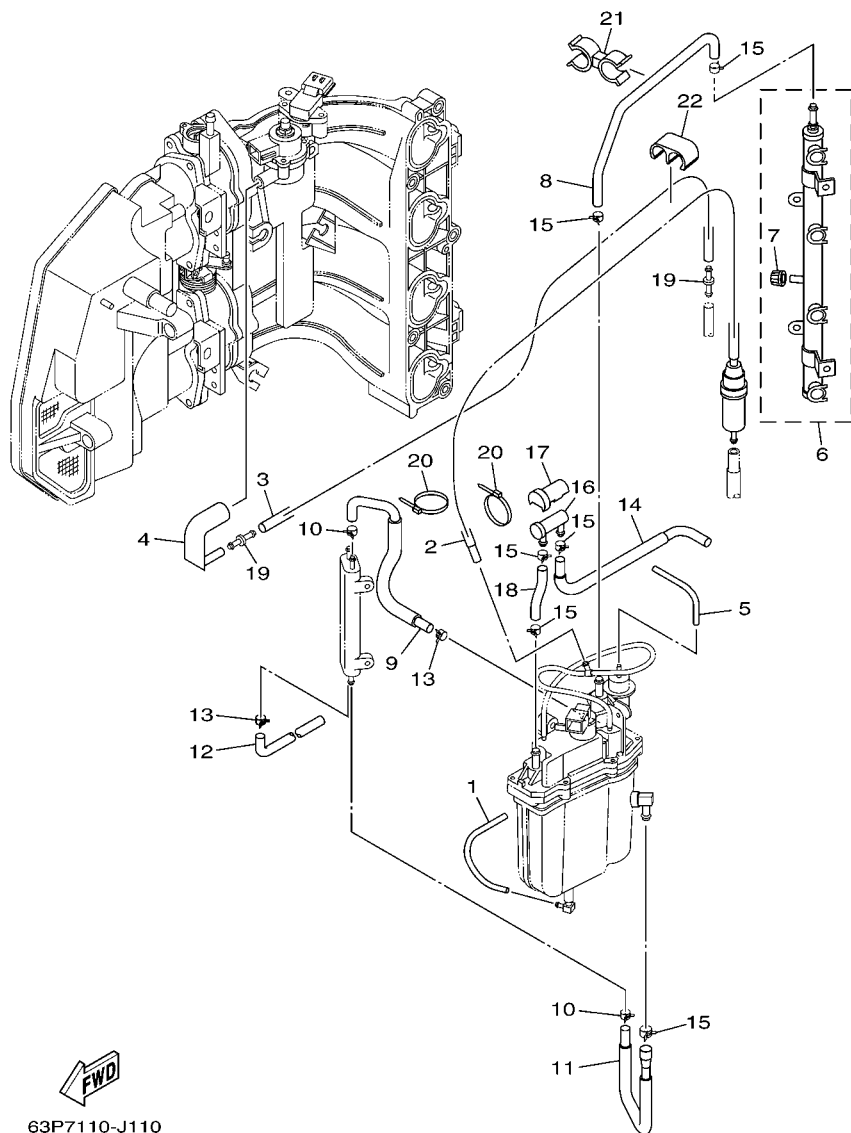
FIG. 10 FUEL INJECTION PUMP 1

BOMBA DE INYECTOR 1

REF. NO.	PART NO. CODIGO N°	DESCRIPTION DESCRIPCION	63P9	64P9	REMARKS OBSERVACIONES
19	63P-13784-10	.COVER, PUMP .CUBIERTA DE BOMBA	1	1	FOR BRA FOR BRA
20	63P-13915-00	.FILTER .FILTRO	1	1	
21	63P-14148-00	PIPE TUBO	2	2	
22	69J-24379-00	PIPE, JOINT 4 TUBO DE UNION 4	1	1	
23	63P-14777-00	BOLT PERNO	3	3	
24	69J-13716-00	COLLAR COLLAR	6	6	
25	6BM-13593-00	DAMPER COJINETE DE RODILLOS	3	3	
26	63P-8259L-00	WIRE HARNESS ASSY 1 CONJUNTO DE CABLES 1	1	1	
27	69J-21841-02	COOLER ENFRIADOR	1	1	
28	68V-14446-00	BOLT PERNO	2	2	

FIG. 11 FUEL INJECTION PUMP 2

BOMBA DE INYECTOR 2



63P7110-J110

REF. NO.	PART NO. CODIGO Nº	DESCRIPTION DESCRIPCION	63P9	64P9	REMARKS OBSERVACIONES
1	63P-14149-00	PIPE TUBO	1	1	
2	63P-13971-00	PIPE, FUEL 1 ANILLO DE ESPACIADOR	1	1	WITH FILTER WITH FILTER
3	63P-13546-00	HOSE 2 SELLO	1	1	
4	63P-13545-00	HOSE 1 SELLO	1	1	
5	63P-13532-10	HOSE, VACUUM SENSING 3 MANGUERA, DE VACIO 3	1	1	
6	63P-13160-00	DELIVERY PIPE ASSY 1 TUBO DE LLEGADA CONJUNTO 1	1	1	
7	63P-14225-00	.CAP .TAPA	1	1	
8	63P-13974-30	PIPE, FUEL 4 TUBO, COMBUSTIBLE 4	1	1	FOR CAR FOR CAR
	63P-13974-20	PIPE, FUEL 4 TUBO, COMBUSTIBLE 4	1	1	FOR BRA FOR BRA
9	63P-13976-30	PIPE, FUEL 6 TUBO, COMBUSTIBLE 6	1	1	FOR CAR FOR CAR
	63P-13976-20	PIPE, FUEL 6 TUBO, COMBUSTIBLE 6	1	1	FOR BRA FOR BRA
10	68V-2411M-00	CLIP PRESILLA	2	2	
11	63P-24317-20	PIPE 7 TUBO 7	1	1	FOR CAR FOR CAR
	63P-24317-10	PIPE 7 TUBO 7	1	1	FOR BRA FOR BRA
12	63P-2247B-00	HOSE 2 TUBO 2	1	1	
13	68V-24519-00	CLIP PRESILLA	2	2	
14	63P-24325-30	PIPE 14 TUBO 14	1	1	FOR CAR FOR CAR
	63P-24325-20	PIPE 14 TUBO 14	1	1	FOR BRA FOR BRA
15	68V-13577-00	CLIP PRESILLA	6	6	
16	69J-24501-10	FILTER, FUEL FIELTRO	1	1	
17	69J-24599-10	CAP SELLO TAPA	1	1	
18	63P-13975-30	PIPE, FUEL 5 TUBO, COMBUSTIBLE 5	1	1	FOR CAR FOR CAR
	63P-13975-20	PIPE, FUEL 5 TUBO, COMBUSTIBLE 5	1	1	FOR BRA FOR BRA
19	6P2-13758-00	PIPE, JOINT TUBO DE JUNTA	2	2	
20	68V-2481H-00	CLAMP GRAMPA	2	2	
21	63P-2417H-00	CLAMP 1 GRAMPA 1	1	1	
22	63P-2417J-00	CLAMP 2 GRAMPA 2	1	1	

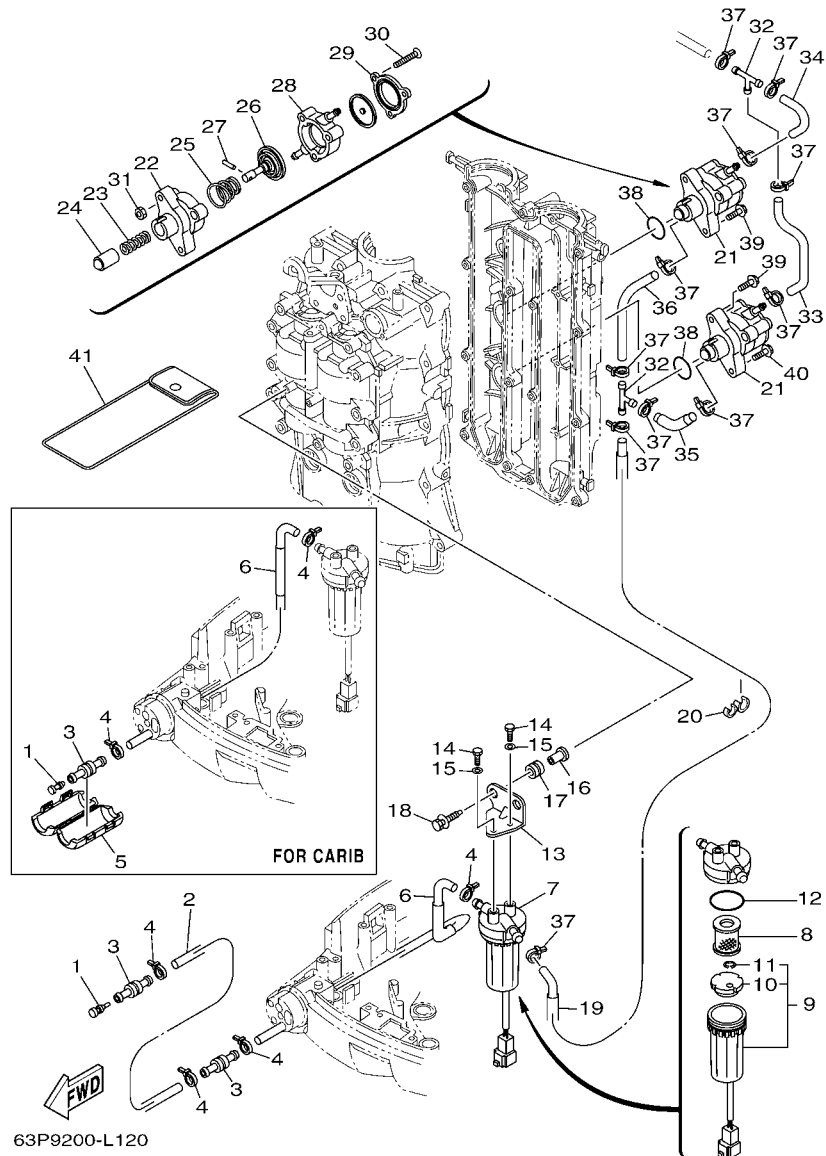


FIG. 12 FUEL 1

COMBUSTIBLE 1

REF. NO.	PART NO. CODIGO Nº	DESCRIPTION DESCRIPCION	63P9	64P9	REMARKS OBSERVACIONES
1	689-85547-00	DAMPER AMORTIGUADOR	1	1	
2	90445-13511	HOSE (L2000) TUBO (L2000)	1	1	FOR BRA FOR BRA
3	6R3-24377-10	PIPE, JOINT 2 TUBO DE UNION 2	2	2	FOR BRA FOR BRA
	6R3-24377-10	PIPE, JOINT 2 TUBO DE UNION 2	1	1	FOR CAR FOR CAR
4	90465-11M10	CLAMP BRIDA	4	4	FOR BRA FOR BRA
	90465-11M10	CLAMP BRIDA	2	2	FOR CAR FOR CAR
5	68V-24452-00	COVER CUBIERTA	1	1	FOR CAR FOR CAR
6	63P-24316-00	PIPE 6 TUBO 6	1	1	FOR BRA FOR BRA
	63P-24316-20	PIPE 6 TUBO 6	1	1	FOR CAR FOR CAR
7	6P3-24560-03	FILTER ASSY FILTRO COMPLETO	1	1	
8	6P3-24563-01	.ELEMENT, FILTER .ELEMENTO DEL FILTRO	1	1	
9	6P3-24562-03	.CUP, FILTER .COPA DE FILTRO	1	1	
10	6P3-24469-00	..FLOAT, WATER LEVEL ..BOIA	1	1	
11	6P3-24519-00	..CLIP ..PRESILLA	1	1	
12	6P3-24564-00	.GASKET .EMPAQUE	1	1	
13	63P-24566-00	BRACKET, FILTER SOPORTE DEL FILTRO	1	1	
14	97095-06014	BOLT PERNO	2	2	
15	92995-06600	WASHER ARANDELA	2	2	
16	90387-06M60	COLLAR ESPACIADOR	2	2	
17	90480-10M23	GROMMET TAPON	2	2	
18	90119-06071	BOLT, WITH WASHER TORNILLO CON ARANDELA	2	2	
19	63P-24311-30	PIPE, FUEL 1 TUBO DE COMBUSTIBLE 1	1	1	FOR BRA FOR BRA
	63P-24311-20	PIPE, FUEL 1 TUBO DE COMBUSTIBLE 1	1	1	FOR CAR FOR CAR
20	90464-13M34	CLAMP BRIDA	1	1	
21	63P-24410-10	FUEL PUMP ASSY BOMBA DE COMBUSTIBLE COMPLETA	2	2	
22	68V-24412-00	.BODY 1 .CUERPO 1	1	1	
23	68V-24454-00	.SPRING .RESORTE	1	1	







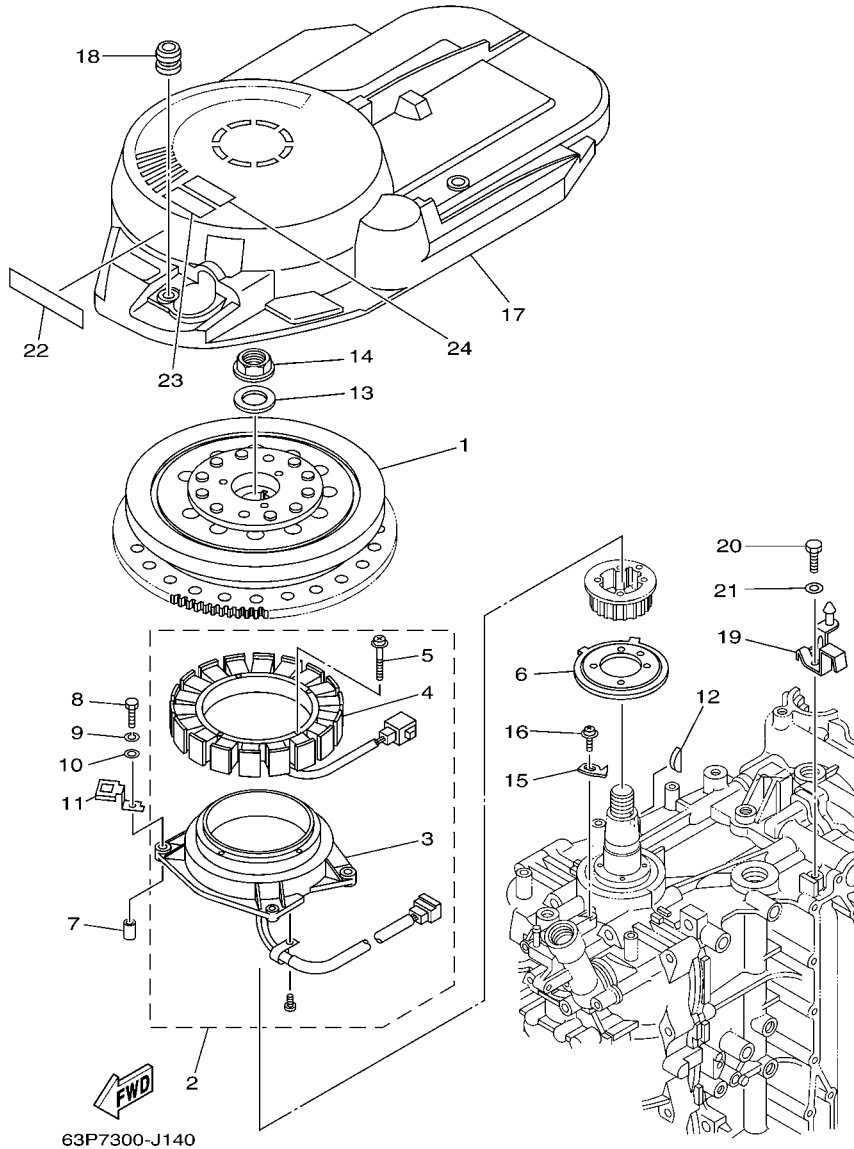
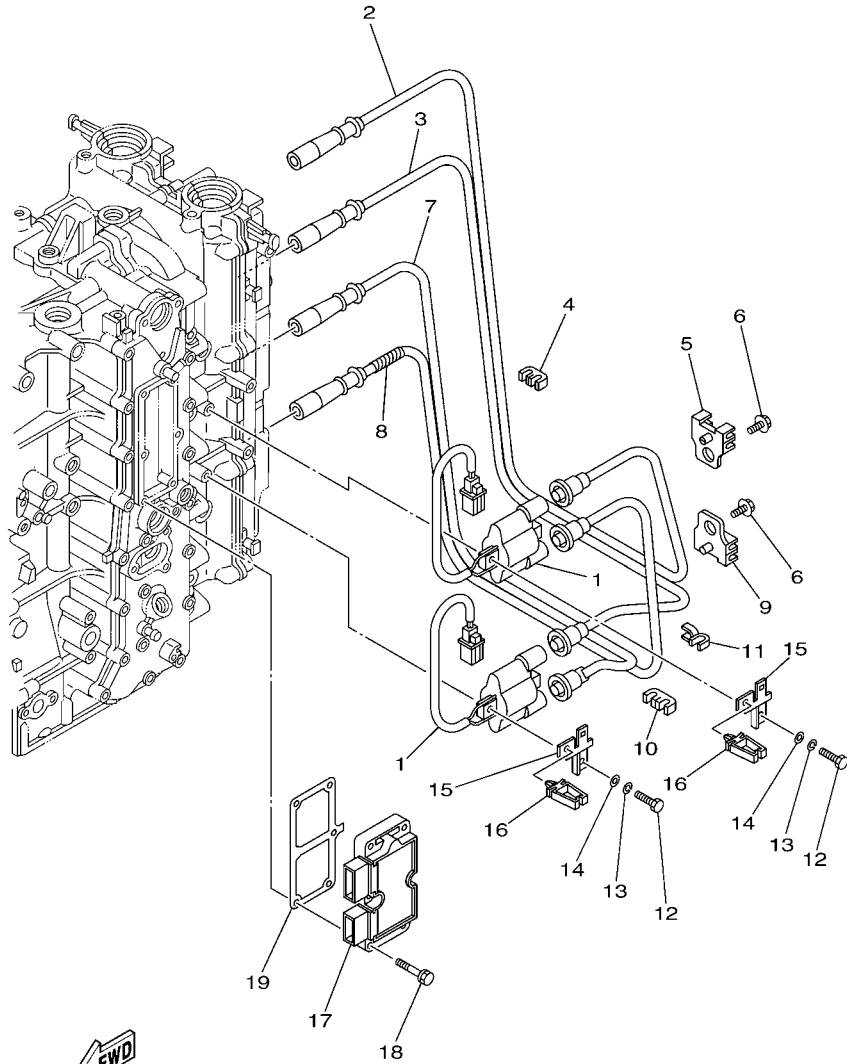


FIG. 14 GENERATOR

GENERADOR

REF. NO.	PART NO. CODIGO Nº	DESCRIPTION DESCRIPCION	63P9	64P9		REMARKS OBSERVACIONES
1	63P-81450-00	ROTOR ASSY ROTOR COMPLETO	1	1		
2	63P-81460-00	BASE ASSY CONJUNTO BASE	1	1		
3	63P-85580-00	.COIL, PULSER .BOBINA DE PULSACION	1	1		
4	63P-81410-00	.STATOR ASSY .ESTATOR COMPLETO	1	1		
5	63D-81345-20	.SCREW, WITH WASHER (M6X30) .TORNILLO, CON ARANDELA (M6X30)	4	4		
6	63P-81673-01	ROTOR ROTOR	1	1		
7	99530-08012	PIN, DOWEL PASADOR, DE ESPIGA	2	2		
8	97095-06035	BOLT PERNO	4	4		
9	92995-06100	WASHER, SPRING ARANDELA	4	4		
10	92995-06600	WASHER ARANDELA	4	4		
11	63P-81845-00	PLATE PLACA	2	2		
12	90280-05015	KEY, WOODRUFF CUNA WOODRUFF	1	1		
13	90201-24014	WASHER, PLATE ARANDELA PLANA	1	1		
14	90179-24002	NUT TUERCA	1	1		
15	6P2-81332-00	PLATE, TIMING PLACA REGULADOR DE TIEMPO	1	1		
16	97985-06210	SCREW, WITH WASHER TORNILLO, CON ARANDELA	1	1		
17	63P-81337-00	COVER, FLYWHEEL CUBIERTA DE VOLANTE	1	1		
18	663-82317-01	DAMPER, IGNITION COIL AMORTIGUADOR BOBINA ENCENDIDO	3	3		
19	63P-8132G-00	PLATE PLACA	1	1		
20	97095-06016	BOLT PERNO	1	1		
21	92995-06600	WASHER ARANDELA	1	1		
22	63P-13437-62	MARK, CAUTION MARKER	1	1		FOR CAR FOR CAR
23	6AH-81994-40	LABEL, SAFETY ETIQUETA DE SEGURIDAD	1	1		FOR CAR FOR CAR
	6AH-81994-70	LABEL, SAFETY ETIQUETA DE SEGURIDAD	1	1		FOR BRA FOR BRA
24	6AH-81994-50	LABEL, SAFETY ETIQUETA DE SEGURIDAD	1	1		FOR CAR FOR CAR



63P7110-J150

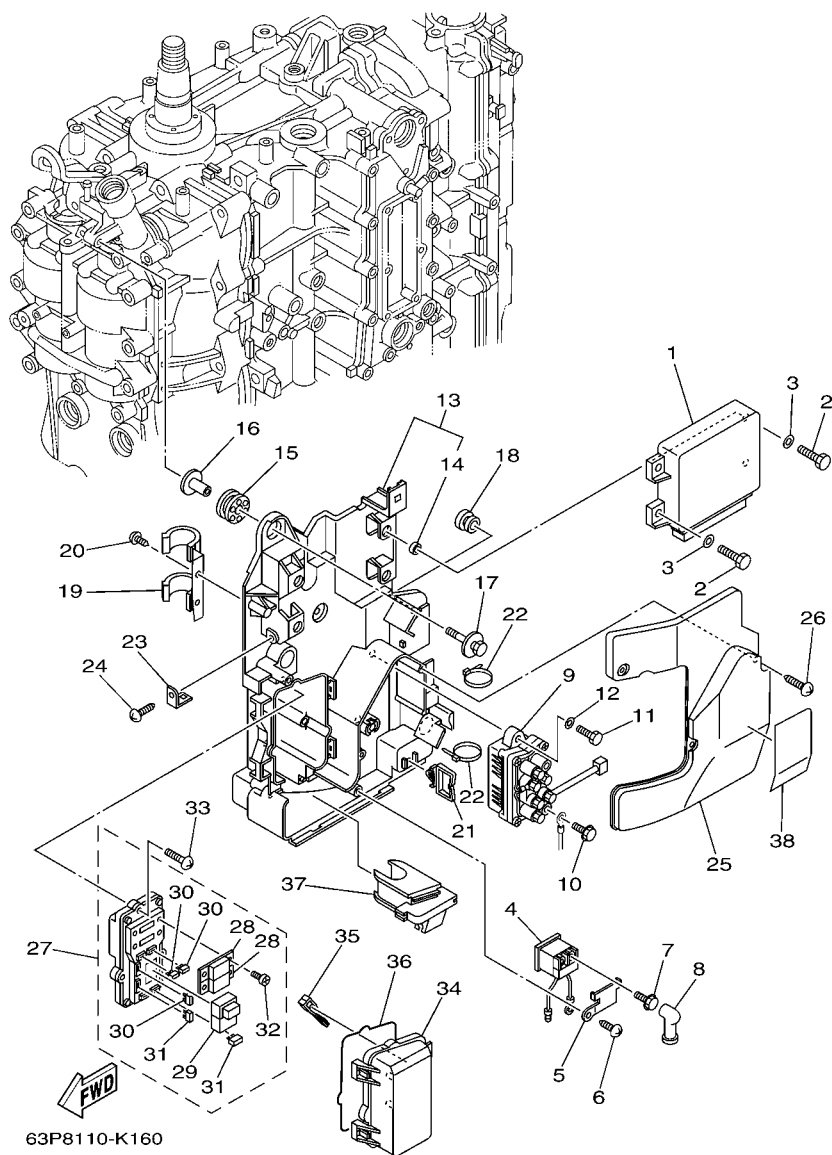
FIG. 15 ELECTRICAL 1

EQUIPO ELECTRICO 1

REF. NO.	PART NO. CODIGO Nº	DESCRIPTION DESCRIPCION	63P9	64P9		REMARKS OBSERVACIONES
1	63P-82310-01	IGNITION COIL ASSY BOBINA DE ENCENDIDO COMPLETA	2	2		
2	63P-82341-00	CORD, HIGH TENSION 1 CABLE DE ALTA TENSION 1	1	1		
3	63P-82342-00	CORD, HIGH TENSION 2 CABLE DE ALTA TENSION 2	1	1		
4	67F-82361-00	CLAMP, CORD GRAMPA DE CABLE	1	1		
5	67F-82362-00	CLAMP, CORD 2 GRAMPA DE CABLE 2	1	1		
6	90119-06134	BOLT, WITH WASHER TORNILLO CON ARANDELA	2	2		
7	63P-82343-00	CORD, HIGH TENSION 3 CABLE DE ALTA TENSION 3	1	1		
8	63P-82344-01	CORD, HIGH TENSION 4 CABLE DE ALTA TENSION 4	1	1		
9	67F-82362-00	CLAMP, CORD 2 GRAMPA DE CABLE 2	1	1		
10	67F-82361-00	CLAMP, CORD GRAMPA DE CABLE	1	1		
11	90464-07M41	CLAMP BRIDA	1	1		
12	97095-06025	BOLT PERNO	4	4		
13	92995-06100	WASHER, SPRING ARANDELA	4	4		
14	92995-06600	WASHER ARANDELA	4	4		
15	63P-82388-00	PLATE PLACA	2	2		
16	90464-05141	CLAMP BRIDA	2	2		
17	63P-81960-01	RECTIFIER & REGULATOR ASSY RECTIFICADOR Y REGULADOR	1	1		
18	90119-06MA4	BOLT, WITH WASHER TORNILLO CON ARANDELA	6	6		
19	63P-81975-00	PLATE, RECTIFIER FITTING PLACA ACCESORIA RECTIF.	1	1		

FIG. 16 ELECTRICAL 2

EQUIPO ELECTRICO 2



63P8110-K160

REF. NO.	PART NO. CODIGO Nº	DESCRIPTION DESCRIPCION	63P9	64P9	REMARKS OBSERVACIONES
1	63P-8591A-63	ENGINE CONTROL UNIT ASSY UNIDAD CONTROL	1	1	FOR CAR
	63P-8591A-73	ENGINE CONTROL UNIT ASSY UNIDAD CONTROL	1	1	FOR CAR FOR BRA
2	97095-06016	BOLT PERNO	4	4	
3	92995-06600	WASHER ARANDELA	4	4	
4	68V-8194A-00	RELAY RELE	1	1	
5	68V-81953-00	STAY, RELAY SOPORTE DE RELE	1	1	
6	97780-60620	SCREW, TAPPING TORNILLO DE CABEZA DE CONO ACH	1	1	
7	97595-06610	BOLT, WITH WASHER PERNO CON ARANDELA	2	2	
8	6G5-82119-00	COVER, LEAD WIRE CUBIERTA DE CABLE CONDUCTOR	2	2	
9	63P-81950-00	RELAY ASSY RELE COMPLETO	1	1	
10	97595-06610	BOLT, WITH WASHER PERNO CON ARANDELA	2	2	
11	97013-06020	BOLT PERNO	2	2	
12	92903-06600	WASHER, PLATE RONDANA SENCILLA	2	2	
13	63P-81948-00	BRACKET SOPORTE	1	1	
14	90387-06010	.COLLAR ESPACIADOR	4	4	
15	68F-85516-01	SPACER ESPACIADOR	3	3	
16	90387-06176	COLLAR ESPACIADOR	3	3	
17	68F-85119-00	BOLT PERNO	3	3	
18	90480-10627	GROMMET TAPON	1	1	
19	63P-82594-00	CLAMP GRAMPA	1	1	
20	97780-60620	SCREW, TAPPING TORNILLO DE CABEZA DE CONO ACH	1	1	
21	90464-23199	CLAMP BRIDA	1	1	
22	90465-13M18	CLAMP BRIDA	3	3	
23	68V-85548-00	HOLDER SOSTEN	1	1	
24	97780-60620	SCREW, TAPPING TORNILLO DE CABEZA DE CONO ACH	1	1	
25	63P-81942-00	COVER CUBIERTA	1	1	
26	90169-05M00	SCREW, TRUSS HEAD TAPPING TORNILLO	3	3	



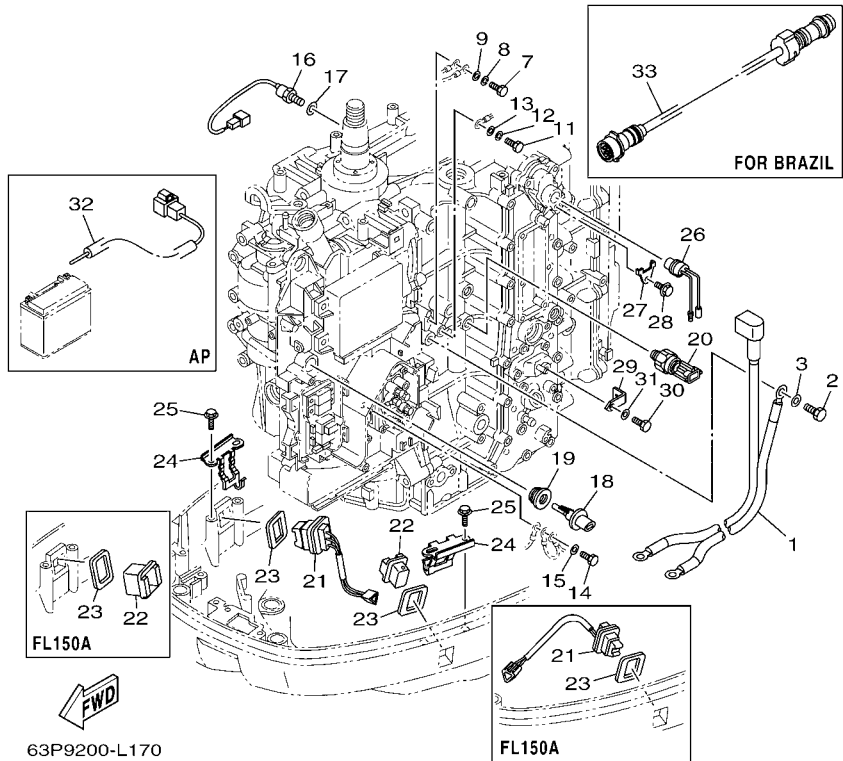
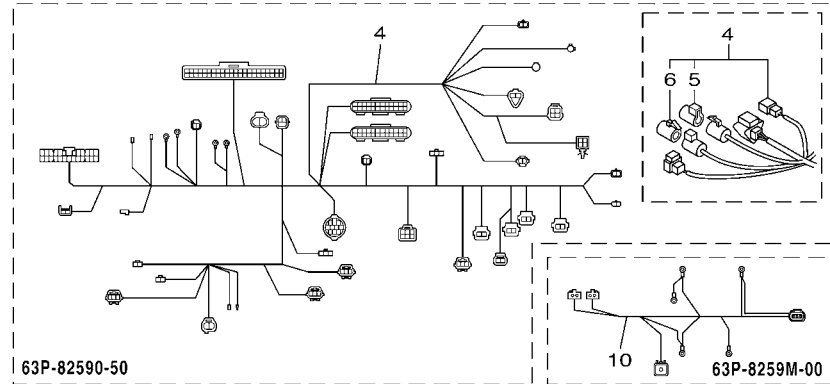


FIG. 17 ELECTRICAL 3

EQUIPO ELECTRICO 3

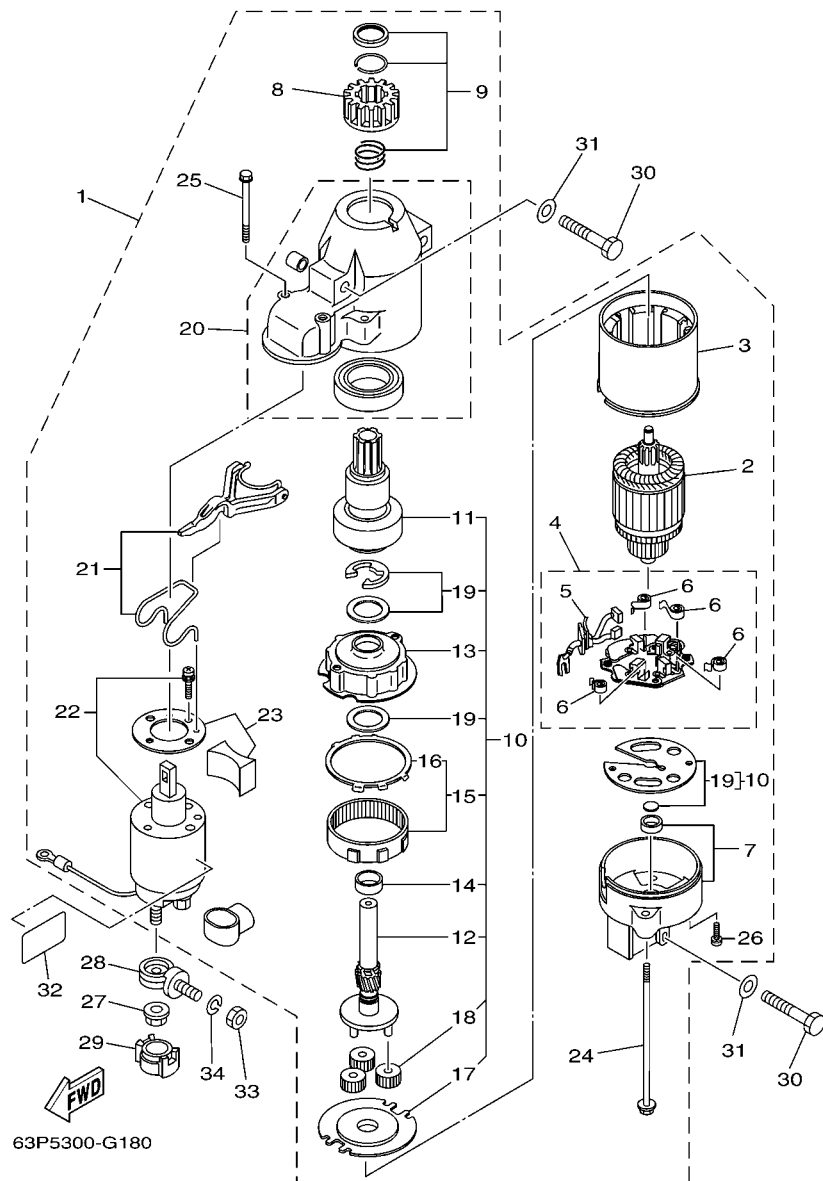
REF. NO.	PART NO. CODIGO Nº	DESCRIPTION DESCRIPCION	63P9	64P9		REMARKS OBSERVACIONES
1	63P-82105-00	WIRE HARNESS ARNES DE CABLES	1	1		
2	97095-08016	BOLT PERNO	1	1		
3	92995-08600	WASHER ARANDELA	1	1		
4	63P-82590-50	WIRE HARNESS ASSY CONJUNTO DE CABLES	1	1		
5	6P2-82582-00	.CAP 1 (FEMALE) .TAPA 1	1	1		
6	6P2-82582-10	.CAP 1 (MALE) .TAPA 1	1	1		
7	97095-06016	BOLT PERNO	1	1		
8	92995-06100	WASHER, SPRING ARANDELA	1	1		
9	92995-06600	WASHER ARANDELA	1	1		
10	63P-8259M-00	WIRE HARNESS ASSY 2 ARNES DE CABLES	1	1		
11	97095-06016	BOLT PERNO	1	1		
12	92995-06100	WASHER, SPRING ARANDELA	1	1		
13	92995-06600	WASHER ARANDELA	1	1		
14	97095-06012	BOLT PERNO	1	1		
15	92995-06600	WASHER ARANDELA	1	1		
16	61A-85790-00	THERMOSENSOR ASSY TERMICA SENSORIO	1	1		
17	92990-10600	WASHER, PLATE ARANDELA PLANA	1	1		
18	63P-85886-00	SENSOR, AIR TEMPERATURE SENSOR	1	1		
19	63P-14435-00	GROMMET ANILLO PROTECTOR	1	1		
20	6AW-83651-00	SENDER, OIL PRESSURE TRASMISOR DE PRESION DE ACEITE	1	1		
21	69J-82563-00	TRIM & TILT SWITCH ASSY INTERRUPTOR DE INCLINACION	1	1		
22	69J-42723-01	COVER, BOTTOM CUBIERTA INFERIOR	1	1		
23	69J-82587-00	GASKET EMPAQUETADURA	2	2		
24	63P-83614-01	BRACKET SOPORTE	2	2		
25	90109-06M86	BOLT PERNO	4	4		
26	6P2-82560-01	THERMO SWITCH ASSY INTER. DE TERMO	1	1		
27	6E9-82588-00	PLATE PLACA	1	1		





FIG. 18 STARTING MOTOR

MOTOR DE ARRANQUE



REF. NO.	PART NO. CODIGO Nº	DESCRIPTION DESCRIPCION	63P9	64P9	REMARKS OBSERVACIONES
1	6BR-81800-01	STARTING MOTOR ASSY MOTOR DE ARRANQUE COMPLETO	1	1	
2	67F-81850-00	..ARMATURE ASSY ..INDUCIDO COMPLETO	1	1	
3	67F-81810-00	..STATOR ASSY ..ESTATOR COMPLETO	1	1	
4	69J-81840-00	..BRUSH HOLDER ASSY ..SOSTEN DE ESCOBILLA COMPLETO	1	1	
5	69J-81801-00	..BRUSH SET ..JUEGO DE ESCOBILLA	1	1	
6	67F-81813-00	..SPRING, BRUSH ..RESORTE DE ESCOBILLA	4	4	
7	67F-81820-00	..REAR BRACKET ASSY ..CUBIERTA TRASERA COMPL	1	1	
8	67F-81808-00	..PINION ASSY ..PINON	1	1	
9	67F-81857-00	..PINION STOPPER SET ..JUEGO TAPON PINON	1	1	
10	67F-81807-00	..GEAR ASSY, STARTING MOTOR ..PINON CONJUNTO	1	1	
11	67F-81832-00	..CLUTCH, OVER RUN ..PINON COMPL	1	1	
12	67F-81836-00	..SHAFT, PINION ..ARBOL, PINON	1	1	
13	67F-81821-00	..BRACKET, CENTER 1 ..SOPORTE, CENTRO 1	1	1	
14	67F-81841-00	..BEARING ..PORTADOR	1	1	
15	67F-81891-00	..GEAR, RING ..ENGRANAJE ANILLO	1	1	
16	67F-8183R-00	..GASKET ..EMPAQUETADURA	1	1	
17	67F-81830-00	..BRACKET, CENTER 2 ..SOPORTE, CENTRO 2	1	1	
18	60V-8183T-00	..GEAR, IDLER ..ENGRANAJE NEUTRO	3	3	
19	67F-81809-00	..WASHER KIT ..JUEGO DE ARANDELA	1	1	
20	69J-81842-00	..COVER ..TAPA	1	1	
21	6C5-81839-00	..LEVER ASSY ..PALANCA COMPL.	1	1	
22	63P-81941-00	..STARTER RELAY ASSY ..RELE DE ARRANQUE	1	1	
23	6C5-81869-00	..COVER, DUST ..CUBIERTA PARA POLVO	1	1	
24	6K7-81826-11	..BOLT ..PERNO	2	2	
25	69J-81828-00	..SCREW 2 ..TORNILLO DE EMPUJE 2	2	2	
26	67F-81846-00	..SCREW ..TORNILLO	2	2	
27	90179-08003	NUT TUERCA	1	1	



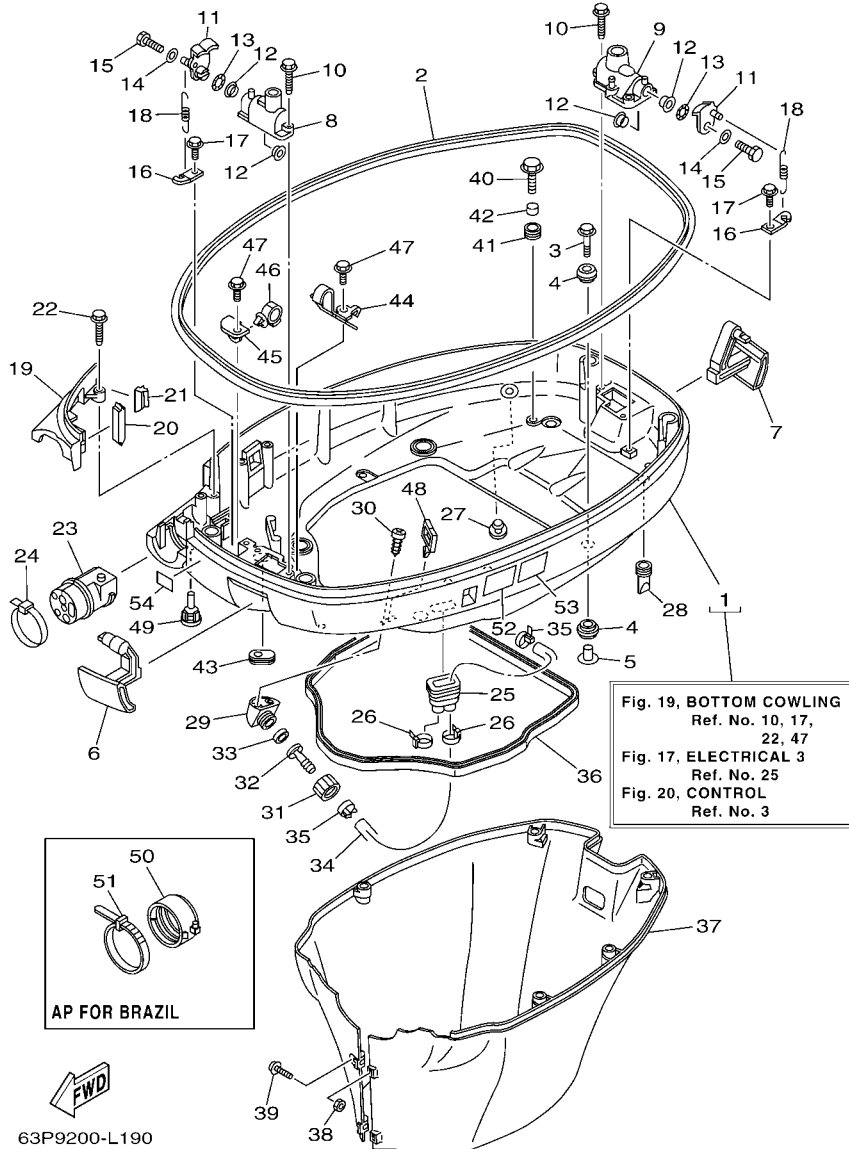


FIG. 19 BOTTOM COWLING

CUBIERTA INFERIOR

REF. NO.	PART NO. CODIGO Nº	DESCRIPTION DESCRIPCION	63P9	64P9	REMARKS OBSERVACIONES
1	63P-42710-01-8D	BOTTOM COWLING ASSY CUBIERTA INFERIOR COMPL.	1	1	
2	63P-42615-00	SEAL SELLO	1	1	
3	90119-08M22	BOLT, WITH WASHER TORNILLO CON ARANDELA	4	4	
4	90480-22M81	GROMMET TAPON	8	8	
5	90387-08M37	COLLAR ESPACIADOR	4	4	
6	63P-42815-00-8D	LEVER, CLAMP PALANCA ABRAZADERA	1	1	
7	63P-42816-00-8D	LEVER, CLAMP PALANCA ABRAZADERA	1	1	
8	68F-42828-03-8D	PLATE, CLAMP PLACA, GRAMPA	1	1	
9	63P-42828-00-8D	PLATE, CLAMP PLACA, GRAMPA	1	1	
10	90109-06M82	BOLT PERNO	4	4	
11	63P-42818-01	LEVER, CLAMP PALANCA, ABRAZADERA	2	2	
12	90386-15M73	BUSH BUJE	4	4	
13	90206-15M18	WASHER, WAVE ARANDELA ONDULADA	2	2	
14	90201-06068	WASHER, PLATE ARANDELA PLANA	2	2	
15	97095-06020	BOLT PERNO	2	2	
16	64D-43144-00	HÖÖK, SPRING GANCHO	2	2	
17	90109-06M86	BOLT PERNO	2	2	
18	90506-16M34	SPRING, TENSION RESORTE DE TENSION	2	2	
19	63P-42738-00-8D	PLATE, FITTING PLACA DE AJUSTE	1	1	
20	63P-42717-00	RUBBER, SEAL 2 GOMA	1	1	
21	63P-42718-00	RUBBER, SEAL 3 GOMA	1	1	
22	90109-06M82	BOLT PERNO	2	2	
23	63P-42725-00	GROMMET TAPON	1	1	
24	90465-13M30	CLAMP BRIDA	1	1	FOR CAR FOR CAR
25	6H1-42726-21	GROMMET TAPON	1	1	
26	90465-11M10	CLAMP BRIDA	2	2	
27	6P2-44391-00	NIPPLE, HOSE NIPLE MANGUERA	1	1	

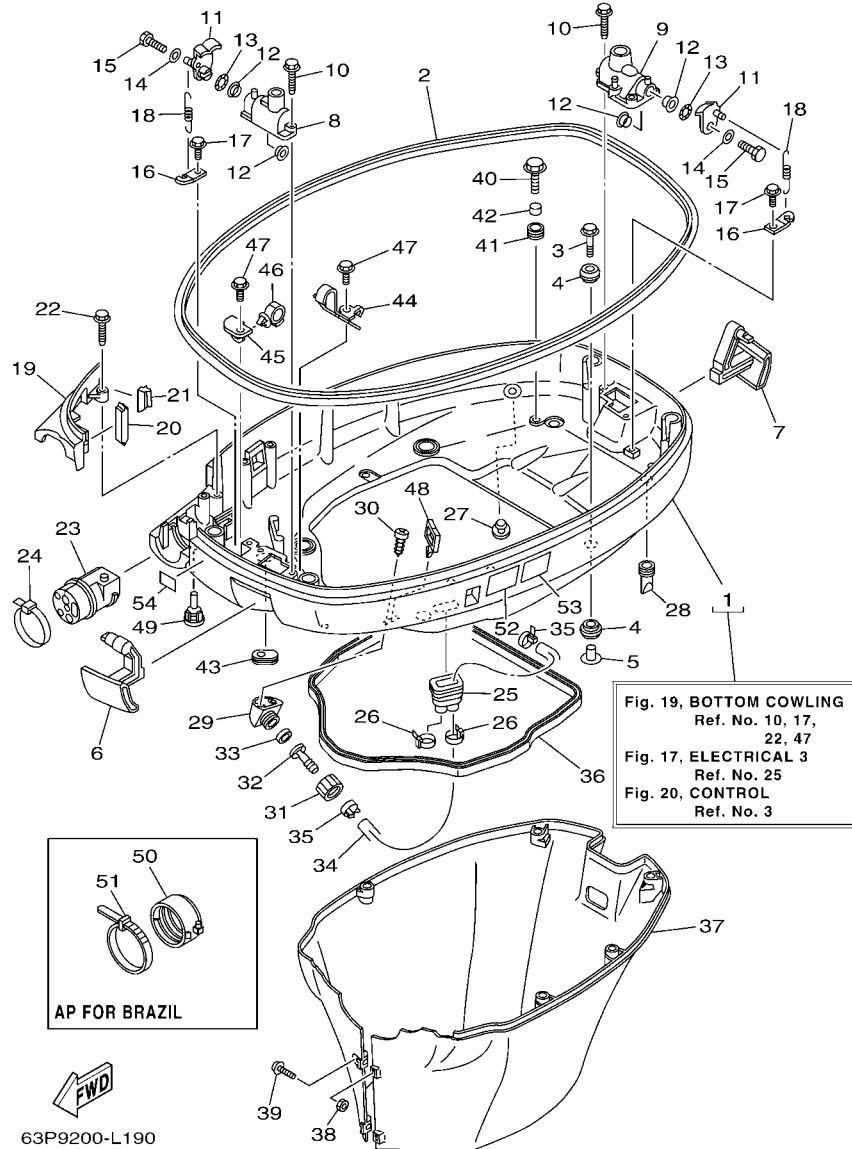
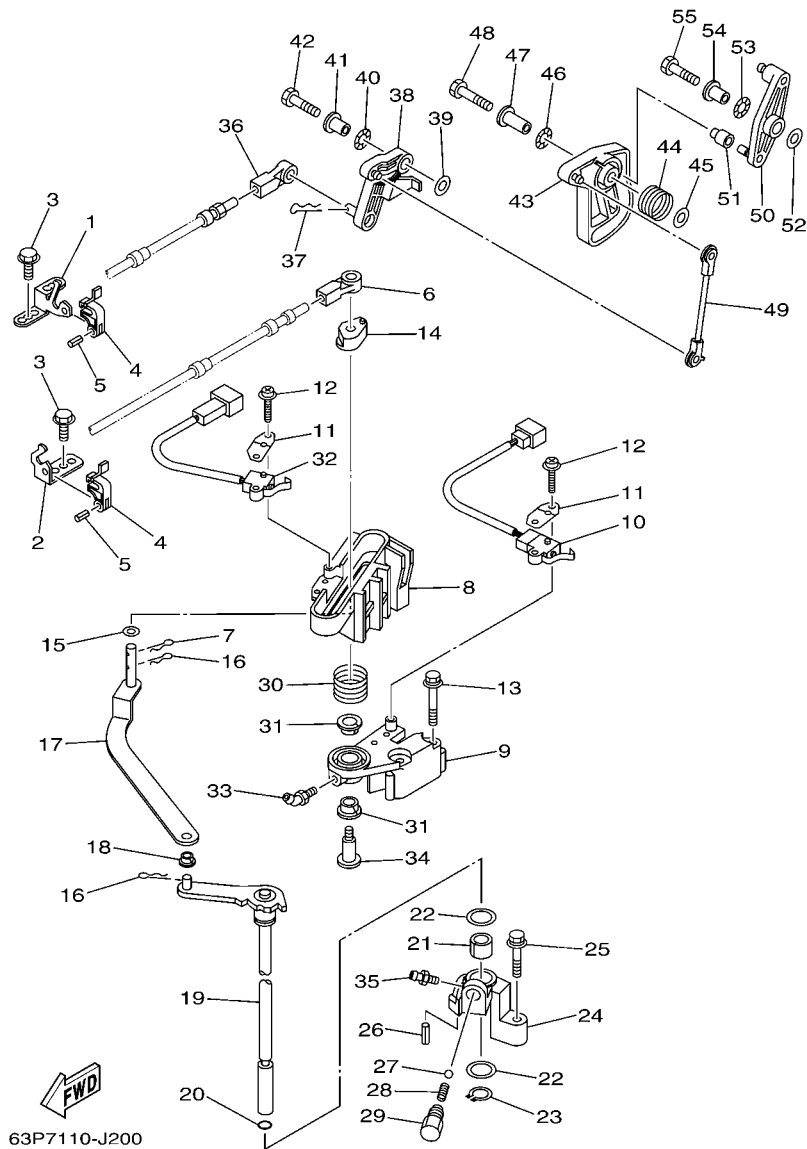


FIG. 19 BOTTOM COWLING

CUBIERTA INFERIOR

REF. NO.	PART NO. CODIGO Nº	DESCRIPTION DESCRIPCION	63P9	64P9	REMARKS OBSERVACIONES
28	61A-42717-00	RUBBER, SEAL 2 GOMA	4	4	
29	68T-12572-00	ADAPTER ADAPTADOR	1	1	
30	97780-60520	SCREW, TAPPING TORNILLO DE CABEZA DE CONO ACH	2	2	
31	6R3-12581-00	JOINT, HOSE 1 CONEXION	1	1	
32	6R3-12582-00	JOINT, HOSE 2 CONEXION	1	1	
33	6R3-12583-00	GASKET, HOSE JOINT EMPAQUETADURA JUNTA DE MANGUE	1	1	
34	63P-42541-00	PIPE 1 TUBO 1	1	1	
35	90465-11M10	CLAMP BRIDA	2	2	
36	63P-42716-00	RUBBER, SEAL 1 SELLO DE GOMA 1	1	1	
37	63P-42741-01-8D	APRON MANDIL	1	1	
38	95380-06600	NUT, HEXAGON TUERCA	2	2	
39	90159-06M28	SCREW, WITH WASHER TORNILLO CON VALONA	2	2	
40	90109-06M80	BOLT PERNO	4	4	
41	90480-13M24	GROMMET TAPON	4	4	
42	90387-06M43	COLLAR ESPACIADOR	4	4	
43	61A-42727-00	GROMMET TAPON	1	1	
44	63P-42811-01	STAY SOPORTE GRAMPA	1	1	
45	63P-42756-00	STAY, CLAMP SOPORTE DE GRAMPA	1	1	
46	90464-20181	CLAMP BRIDA	1	1	
47	90109-06M86	BOLT PERNO	2	2	
48	90464-23199	CLAMP BRIDA	1	1	
49	6H4-42748-00	GROMMET TAPON	2	2	
50	68F-42753-00	FASTNER TIRADOR	1	1	AP FOR BRA AP FOR BRA
51	90464-20258	CLAMP BRIDA	1	1	AP FOR BRA AP FOR BRA
52	6AH-42794-40	LABEL, WARNING (GENERAL) ETIQUETA DE PRECAUCION	1	1	FOR CAR FOR CAR
52	6AH-42794-70	LABEL, WARNING (GENERAL) ETIQUETA DE PRECAUCION	1	1	FOR BRA FOR BRA
53	6AH-42794-50	LABEL, WARNING (GENERAL) ETIQUETA DE PRECAUCION	1	1	FOR CAR FOR CAR



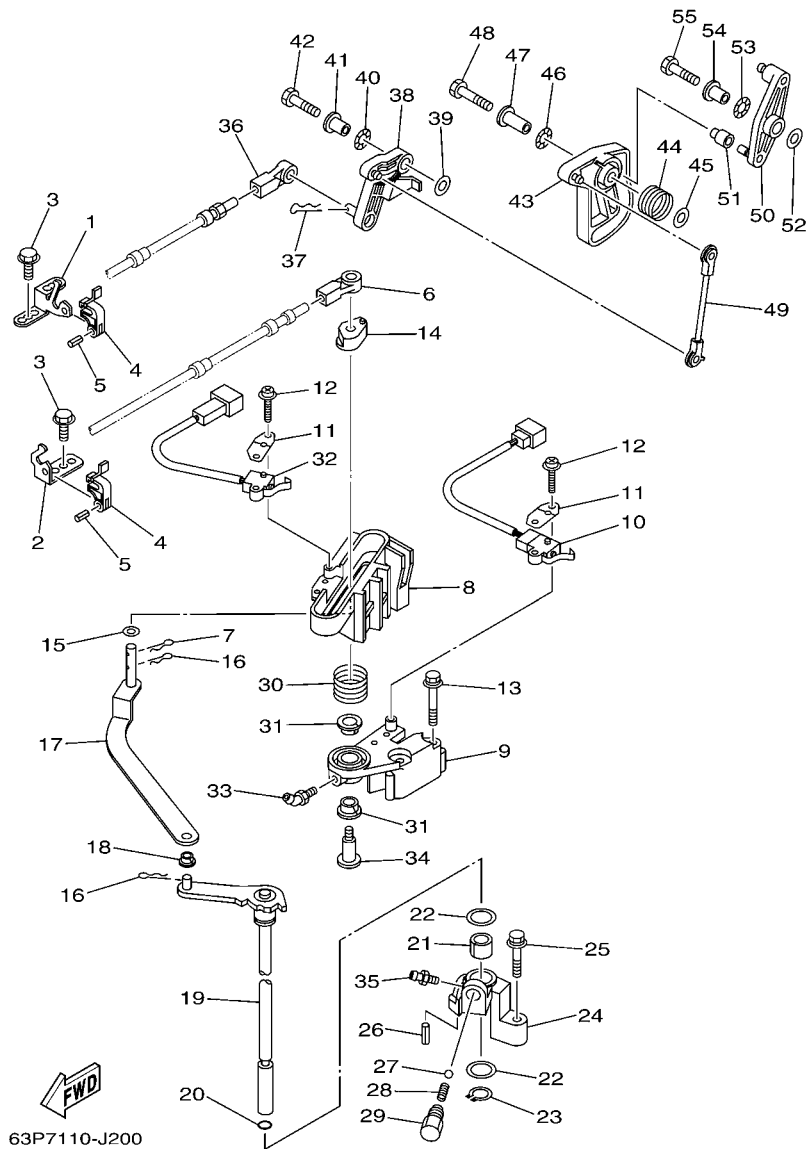


63P7110-J200

FIG. 20 CONTROL

CONTROL

REF. NO.	PART NO. CODIGO Nº	DESCRIPTION DESCRIPCION	63P9	64P9		REMARKS OBSERVACIONES
1	63P-48531-00	BRACKET, REMOTE CONTROL 1 SOPORTE DE CONTROL REMOTO	1	1		
2	63P-48532-00	BRACKET, REMOTE CONTROL 2 SOPORTE DE CONTROL REMOTO	1	1		
3	90109-06M86	BOLT PERNO	3	3		
4	63P-48538-00	CLAMP, CABLE 1 GRAMPA DE CABLE	2	2		
5	91690-30010	PIN, SPRING PASADOR DE RESORTE	2	2		
6	6E5-48344-00	CABLE END, REMOTE CONTROL BASE CONTROL	1	1		
7	90468-18008	CLIP PRESILLA	1	1		
8	63P-44176-00	BRACKET SOPORTE	1	1		
9	63P-44117-00	BRACKET SOPORTE	1	1		
10	69J-8259F-00	SWITCH ASSY INTERRUPTOR	1	1		
11	61A-82588-01	PLATE PLACA	2	2		
12	97985-04116	SCREW, WITH WASHER TORNILLO, CON ARANDELA	4	4		
13	97595-06550	BOLT, WITH WASHER PERNO CON ARANDELA	2	2		
14	63P-44122-00	BUSHING, SHIFT ROD LEVER BUJE PALANCA VARILLA DE CAMBIO	1	1		
15	90202-08M20	WASHER, PLATE ARANDELA DE PLANA	1	1		
16	90468-18008	CLIP PRESILLA	2	2		
17	63P-44121-00	LEVER, SHIFT ROD PALANCA VARILLA CAMBIOS	1	1		
18	90386-06M12	BUSH BUJE	1	1		
19	63P-44120-00	HANDLE GEAR SHIFT ASSY MANIJA DE CAMBIO COMPL	1	1		
20	93210-09165	O-RING ANILLO O	1	1		
21	90386-16M66	BUSH BUJE	1	1		
22	90202-16061	WASHER, PLATE ARANDELA DE PLANA	2	2		
23	93410-16006	CIRCLIP SEGURO	1	1		
24	63P-44118-00	BRACKET SOPORTE	1	1		
25	97575-06535	BOLT, WITH WASHER PERNO CON ARANDELA	1	1		
26	91690-30010	PIN, SPRING PASADOR DE RESORTE	1	1		
27	93501-04M02	BALL BOLA	1	1		



63P7110-J200

FIG. 20 CONTROL

CONTROL

REF. NO.	PART NO. CODIGO Nº	DESCRIPTION DESCRIPCION	63P9	64P9	REMARKS OBSERVACIONES
28	90501-12082	SPRING, COMPRESSION RESORTE DE COMPRESION	1	1	
29	648-42715-00	BUSHING BUJE	1	1	
30	90508-20M31	SPRING, TORSION RESORTE DE TORSION	1	1	
31	90386-12069	BUSH BUJE	2	2	
32	60V-8259F-00	SWITCH ASSY INTERRUPTOR	1	1	
33	93700-06M01	NIPPLE, GREASE BOQUILLA DE ENGRASAR	1	1	
34	90109-08019	BOLT PERNO	1	1	
35	93700-06M03	NIPPLE, GREASE BOQUILLA DE ENGRASAR	1	1	
36	6E5-48344-00	CABLE END, REMOTE CONTROL BASE CONTROL	1	1	
37	90468-18008	CLIP PRESILLA	1	1	
38	63P-42154-00	LEVER, THROTTLE CONTROL PALANCA CONTROL ACELERADOR	1	1	
39	90201-06M31	WASHER, PLATE ARANDELA PLANA	1	1	
40	90206-10M04	WASHER, WAVE ARANDELA ONDULADA	1	1	
41	90387-06M29	COLLAR ESPACIADOR	1	1	
42	97095-06025	BOLT PERNO	1	1	
43	63P-41213-00	CAM, ACCEL. LEVA ACELERADOR	1	1	
44	69J-44135-00	SPRING RESORTE	1	1	
45	90201-06M31	WASHER, PLATE ARANDELA PLANA	1	1	
46	90206-10M04	WASHER, WAVE ARANDELA ONDULADA	1	1	
47	90387-06M82	COLLAR ESPACIADOR	1	1	
48	97095-06035	BOLT PERNO	1	1	
49	63P-41237-00	JOINT, LINK CONECTOR	1	1	
50	63P-42157-00	LEVER, THROTTLE PALANCA DE ACELERADOR	1	1	
51	68V-42171-00	BUSHING BUJE	1	1	
52	90201-06M31	WASHER, PLATE ARANDELA PLANA	1	1	
53	90206-10M04	WASHER, WAVE ARANDELA ONDULADA	1	1	
54	90387-06M29	COLLAR ESPACIADOR	1	1	





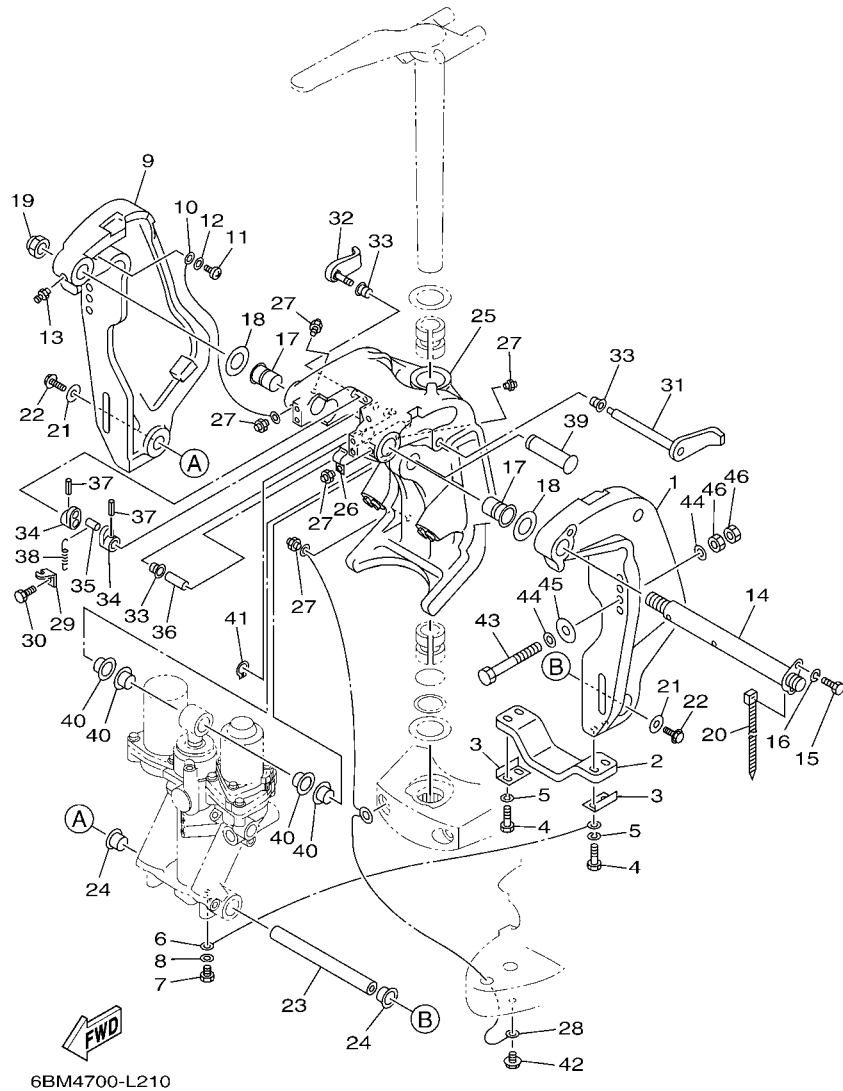


FIG. 21 BRACKET 1

SOPORTE 1

REF. NO.	PART NO. CODIGO Nº	DESCRIPTION DESCRIPCION	63P9	64P9	REMARKS OBSERVACIONES
1	64E-43111-02-8D	BRACKET, CLAMP 1 SOPORTE DE LA ABRAZADERA 1	1	1	
2	6G5-45251-02	ANODE CATODE	1	1	
3	6G5-44526-00	PLATE PLACA 1	2	2	
4	97095-06030	BOLT PERNO	4	4	
5	92995-06100	WASHER, SPRING ARANDELA	4	4	
6	6E5-82148-00	WIRE, LEAD 4 CABLE CONDUCTOR 4	1	1	
7	97095-06010	BOLT PERNO	1	1	
8	92995-06600	WASHER ARANDELA	1	1	
9	64E-43112-02-8D	BRACKET, CLAMP 2 SOPORTE DE LA ABRAZADERA 2	1	1	
10	6E5-82148-00	WIRE, LEAD 4 CABLE CONDUCTOR 4	1	1	
11	97885-06012	SCREW, PAN HEAD TORNILLO A MUESCA	1	1	
12	92995-06600	WASHER ARANDELA	1	1	
13	93700-06M03	NIPPLE, GREASE BOQUILLA DE ENGRASAR	1	1	
14	64E-43131-01	BOLT, CLAMP BRACKET TORNILLO DE ABRAZADERA DEL SOP	1	1	
15	97095-08020	BOLT PERNO	1	1	
16	92995-08100	WASHER ARANDELA	1	1	
17	90386-25M31	BUSH BUJE	2	2	
18	90201-26M59	WASHER, PLATE ARANDELA PLANA	2	2	
19	90185-22M11	NUT, SELF-LOCKING TUERCA AUTOBLOCANTE	1	1	
20	90465-11M10	CLAMP BRIDA	1	1	
21	90201-10060	WASHER, PLATE ARANDELA PLANA	2	2	
22	97575-10530	BOLT, WITH WASHER PERNO CON ARANDELA	2	2	
23	6BC-43818-00	PIN, LOWER SHOCK MOUNT PASADOR AMORTIGUADOR INFERIOR	1	1	
24	90386-22M98	BUSH BUJE	2	2	
25	64E-43311-10-8D	BRACKET, SWIVEL 1 SOPORTE GIRATORIO 1	1	1	
26	90465-08M63	CLAMP BRIDA	1	1	
27	93700-06M03	NIPPLE, GREASE BOQUILLA DE ENGRASAR	5	5	

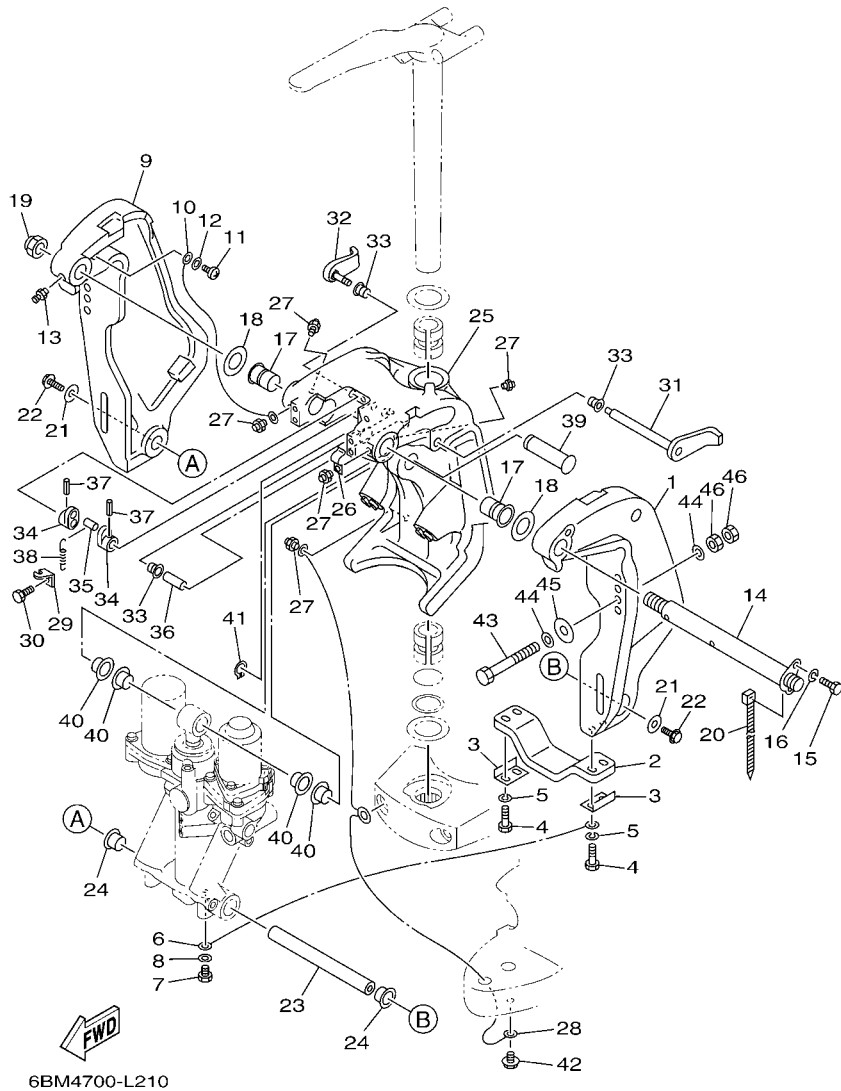
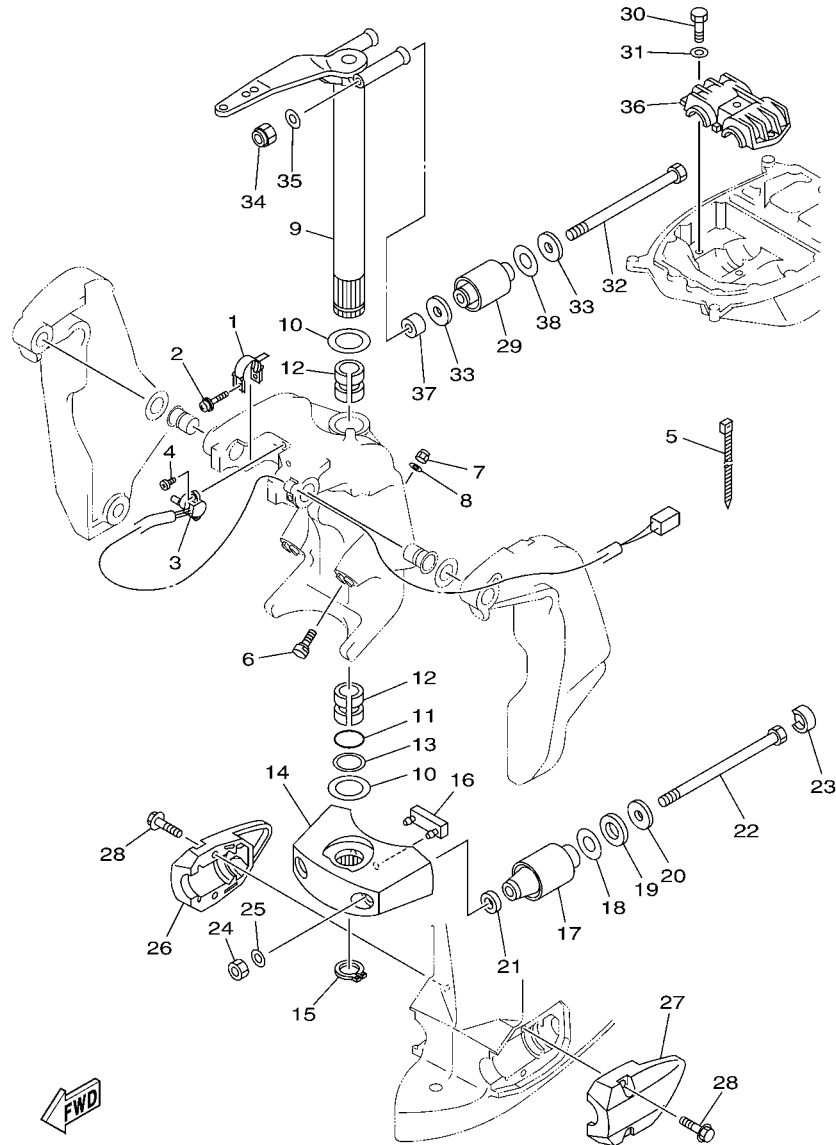


FIG. 21 BRACKET 1

SOPORTE 1

REF. NO.	PART NO. CODIGO Nº	DESCRIPTION DESCRIPCION	63P9	64P9	REMARKS OBSERVACIONES
28	66K-82149-00	WIRE, LEAD 3 CABLE CONDUCTOR 3	1	1	
29	6G5-43144-00	HOOK, SPRING GANCHO	1	1	
30	97095-06010	BOLT PERNO	1	1	
31	6G5-43181-02	LEVER, TILT STOP 1 PALANCA TOPE INCLINACION 1	1	1	
32	6G5-43185-02	LEVER, TILT STOP 2 PALANCA TOPE INCLINACION 2	1	1	
33	90386-10M16	BUSH BUJE	3	3	
34	6G5-43148-00	COLLAR, DISTANCE COLLAR	2	2	
35	90249-06M19	PIN PASADOR	1	1	
36	90387-10M05	COLLAR ESPACIADOR	1	1	
37	91690-30020	PIN, SPRING PASADOR DE RESORTE	2	2	
38	90506-16003	SPRING, TENSION RESORTE DE TENSION	1	1	
39	64E-43126-00	PIN, UPPER SHOCK MOUNT PASADOR DE AMORTIGUADOR SUPERIOR	1	1	
40	90386-22M98	BUSH BUJE	4	4	
41	93410-22M11	CIRCLIP SEGURO	1	1	
42	95895-06010	BOLT, FLANGE TORNILLO DE REBORDE	1	1	
43	90101-12M05	BOLT (L:130MM) TORNILLO (L:130MM)	4	4	FOR CAR FOR CAR
	90101-12M05	BOLT (L:130MM) TORNILLO (L:130MM)	2	2	FOR BRA FOR BRA
	90101-12M77	BOLT (L:150MM) TORNILLO (L:150MM)	2	2	FOR BRA FOR BRA
44	90201-13M01	WASHER, PLATE ARANDELA PLANA	8	8	
45	90201-12426	WASHER, PLATE ARANDELA PLANA	4	4	
46	95380-12600	NUT TUERCA	8	8	

**FWD**  
63P6110-H220



**FIG. 22 BRACKET 2**

**SOPORTE 2**

REF. NO.	PART NO. CODIGO Nº	DESCRIPTION DESCRIPCION	63P9	64P9	REMARKS OBSERVACIONES
1	64E-43139-10	CAM, TRIM SENDER LEVA TRANSMISOR DE INCLINDOR	1	1	
2	90159-05059	SCREW, WITH WASHER TORNILLO CON VALONA	1	1	
3	67H-83672-01	TRIM SENDER TRANSMISOR DE INCLINADOR	1	1	
4	97885-06016	SCREW, PAN HEAD TORNILLO A MUESCA	2	2	
5	90465-11M10	CLAMP BRIDA	3	3	
6	63P-43376-00	BOLT, THRUST RECEIVER TORNILLO RECEPTOR	2	2	
7	95780-10300	NUT, FLANGE TUERCA	2	2	
8	92995-10600	WASHER ARANDELA	2	2	
9	66K-42510-02-8D	STEERING BRACKET ASSY SOPORTE DIRECCION COMPL.	1	1	
10	90201-38M60	WASHER, PLATE ARANDELA PLANA	2	2	
11	93210-37MH7	O-RING ANILLO O	1	1	
12	90386-38M32	BUSH BUJE	2	2	
13	90202-40M47	WASHER, PLATE ARANDELA DE PLANA	1	1	
14	68V-44551-00-8D	HOUSING, LOWER MOUNT RUBBER 1 CAJA AMORTIGUADOR INFERIOR HU	1	1	
15	93410-37M04	CIRCLIP SEGURO	1	1	
16	61A-44575-00	DAMPER, LOWER MOUNT RUBBER AMORTIGUADOR INFERIOR	1	1	
17	60V-44555-00	MOUNT DAMPER, LOWER SIDE AMORTIGUADOR DE HULE LADO INFE	2	2	L(20.3") L(20.3")
	63P-44555-00	MOUNT DAMPER, LOWER SIDE AMORTIGUADOR DE HULE LADO INFE	2	2	X(25.3") X(25.3")
18	90201-35008	WASHER, PLATE ARANDELA PLANA	2	2	
19	90202-32M19	WASHER, PLATE ARANDELA DE PLANA	2	2	
20	90201-16M55	WASHER, PLATE ARANDELA PLANA	2	2	
21	90201-15M58	WASHER, PLATE ARANDELA PLANA	2	2	
22	90109-14007	BOLT PERNO	2	2	
23	69J-44533-00	DAMPER, UPPER MOUNT RUBBER AMORTIGUADOR SUPERIOR	2	2	
24	95380-14600	NUT TUERCA	2	2	
25	92995-14600	WASHER ARANDELA	2	2	
26	63P-44553-00-8D	COVER, LOWER MOUNT CUBIERTA, AMORTIGUADOR INFERIOR	1	1	



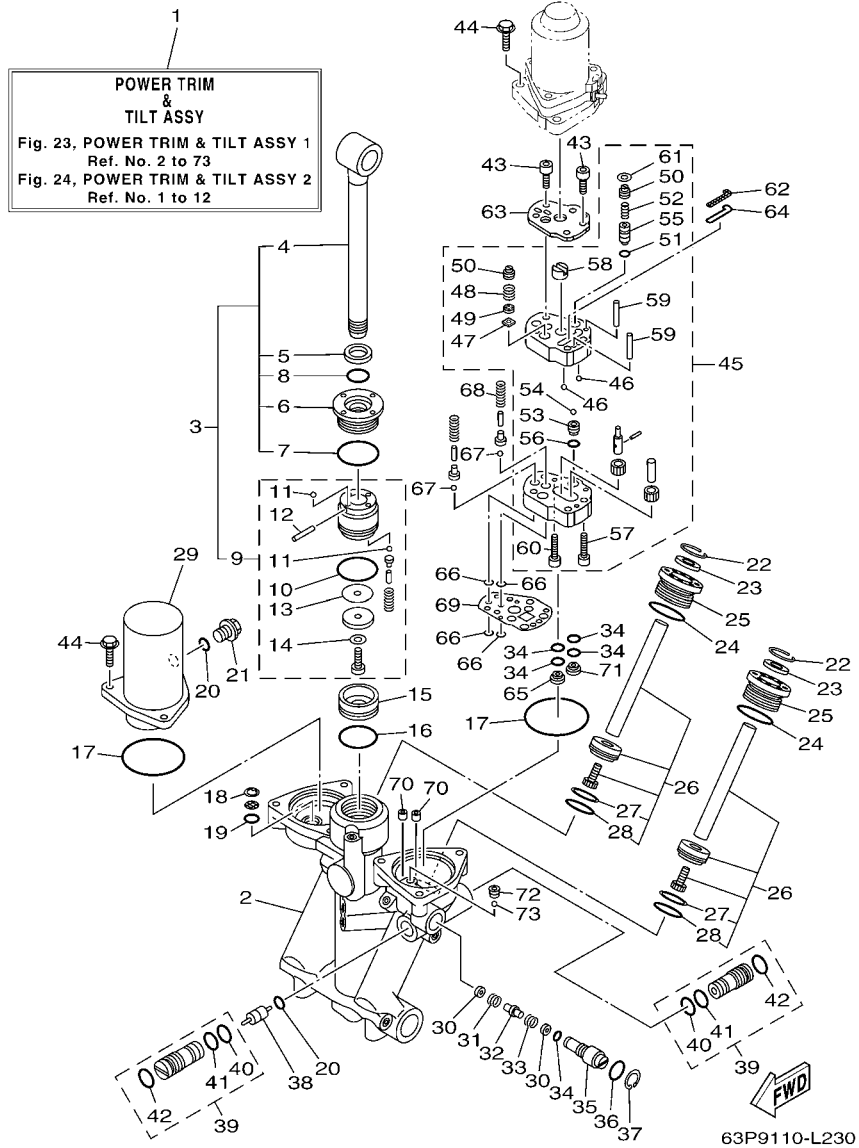
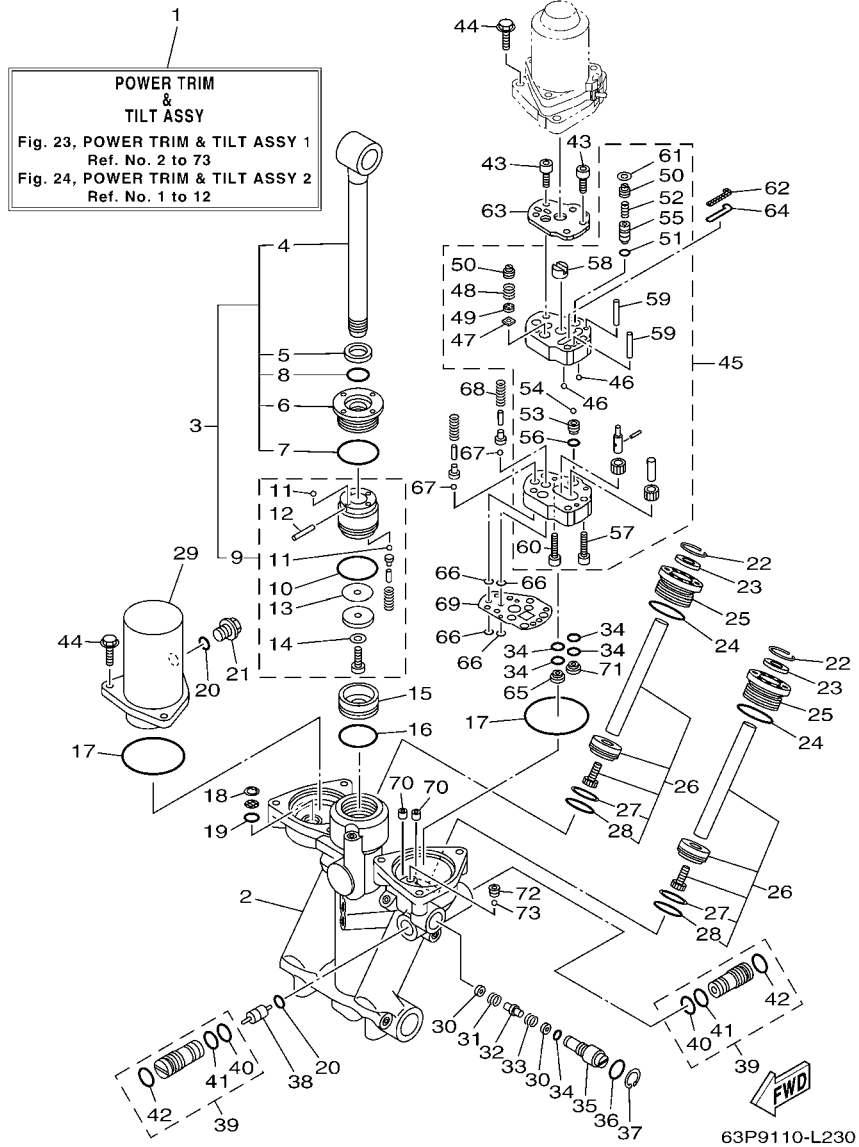


FIG. 23 POWER TRIM & TILT ASSY 1 COMPONER Y PODER VARILLA 1

REF. NO.	PART NO. CODIGO N°	DESCRIPTION DESCRIPCION	63P9	64P9	REMARKS OBSERVACIONES
1	63P-43800-10	POWER TRIM & TILT ASSY ELEVADOR HIDRAULICO COMPL.	1	1	
2	63P-4380L-10	HOUSING, TRIM & TILT SUB ASSY CAJA, INCLINACION Y ADRNO	1	1	
3	63P-43810-10	TILT PISTON SUB ASSY ELEVADOR SUB-PISTON COMPL.	1	1	
4	63P-43801-10	.ROD .VALILLA COMPL INCLINACION	1	1	
5	93106-19N50	.OIL SEAL .SELLO ACEITE	1	1	
6	63P-43811-10	.SCREW, CYLINDER END .TORNILLO CILINDRO EXTREMO	1	1	
7	6H1-43861-00	.O-RING .ANILLO EN O 1	1	1	
8	63P-43863-10	.O-RING .ANILLO EN O 3	1	1	
9	63P-4380P-10	.PISTON SUB ASSY .SUB-PISTON COMPL	1	1	
10	6H1-43862-00	.O-RING .ANILLO EN O 2	1	1	
11	93505-32038	.BALL .BOLA	5	5	
12	91609-16012	.PIN, SPRING .PASADOR DE RESORTE	1	1	
13	35R-22435-A0	.PLATE, VALVE 2 .PLACA DE VALVULA 2	1	1	
14	92902-06200	.WASHER .ARANDELA	1	1	
15	63P-43814-10	PISTON, FREE PISTON LIBRE	1	1	
16	6H1-43862-00	O-RING ANILLO EN O 2	1	1	
17	93210-68N50	O-RING ANILLO O	2	2	
18	63P-43876-10	RING, SNAP ANILLO	1	1	
19	93210-11N52	O-RING ANILLO O	1	1	
20	93210-09165	O-RING ANILLO O	2	2	
21	63P-43829-10	PLUG, RESERVOIR TAPON DEPOSITO	1	1	
22	63P-43875-10	RING, SNAP ANILLO	2	2	
23	6H1-43822-10	SEAL, TRIM DUST SELLO DE POLVO	2	2	
24	63P-43862-10	O-RING ANILLO EN O 2	2	2	
25	63P-43821-10	SCREW, TRIM CYLINDER END TORNILLO CILINDRO EXTREMO	2	2	
26	63P-43820-10	TRIM PISTON SUB ASSY ELEVADOR PISTON COMPL.	2	2	
27	62X-43871-00	.RING, BACK UP .ANILLO	1	1	



**FIG. 23 POWER TRIM & TILT ASSY 1 COMPONER Y PODER VARILLA 1**

REF. NO.	PART NO. CODIGO N°	DESCRIPTION DESCRIPCION	63P9	64P9	REMARKS OBSERVACIONES
28	93210-29375	.O-RING .ANILLO O	1	1	
29	63P-43828-10	BODY, RESERVOIR CUERPO DEPOSITO	1	1	
30	63P-43847-10	SEAT, MANUAL VALVE ASIENTO VALVULA MANUAL	2	2	
31	63P-43854-10	SPRING, MANUAL RELEASE RESORTE DESCOPLO MANUAL	1	1	
32	63P-4382A-10	ADAPTOR 1 ADAPTADOR 1	1	1	
33	63P-4384H-10	SPRING RESORTE	1	1	
34	69J-4389J-00	O-RING ANILLO O	5	5	
35	63P-43845-10	SCREW, MANUAL RELEASE TORNILLO DESCOPLO MANUAL	1	1	
36	93210-18397	O-RING ANILLO O	1	1	
37	6H1-43875-00	RING, SNAP ANILLO	1	1	
38	6H1-43841-11	PISTON, SHUTTLE PISTON	1	1	
39	63P-43802-10	VALVE SUB ASSY VALVULA PRINCIPAL COMPL.	2	2	
40	93210-12N52	.O-RING .ANILLO O	1	1	
41	93210-10M74	.O-RING .ANILLO O	1	1	
42	6H1-43866-01	.O-RING .ANILLO EN O 6	1	1	
43	91318-05040	BOLT TORNILLO	4	4	
44	97595-06625	BOLT, WITH WASHER PERNO CON ARANDELA	6	6	
45	63P-43830-10	GEAR PUMP ASSY ENGRANAJE BOMBA COMPL.	1	1	
46	93503-16003	.BALL .ESFERA	2	2	
47	6H1-4384G-11	.SEAL, RELIEF VALVE .ASIENTO	1	1	
48	6H1-43856-10	.SPRING, DOWN RELIEF .RESORTE SEGURIDAD	1	1	
49	6H1-43844-10	.PIN, VALVE SUPPORT .PASADOR VALVULA SOPORTE	1	1	
50	63P-43843-10	.SCREW, VALVE LOCK .TORNILLO	2	2	
51	93210-064A5	.O-RING .ANILLO O	1	1	
52	69J-43855-00	.SPRING, UP RELIEF .RESORTE SEGURIDAD SUPERIOR	1	1	
53	63P-43851-10	.SEAT, RELIEF VALVE .ASIENTO VALVULA DE DESCARGA	1	1	
54	93501-08001	.BALL .BOLA	1	1	

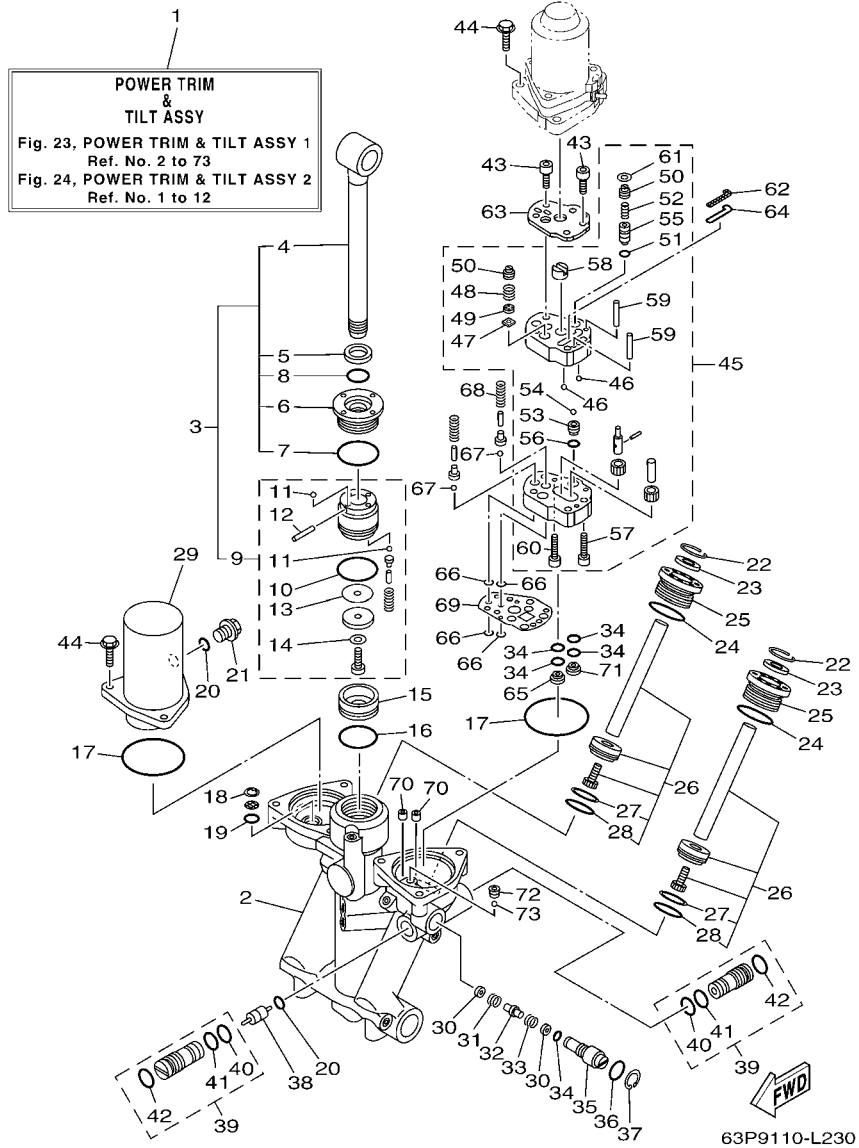


FIG. 23 POWER TRIM & TILT ASSY 1 COMPONER Y PODER VARILLA 1

REF. NO.	PART NO. CODIGO N°	DESCRIPTION DESCRIPCION	63P9	64P9	REMARKS OBSERVACIONES
55	6CJ-43844-00	.PIN, VALVE SUPPORT .PASADOR VALVULA SOPORTE	1	1	
56	93210-07N51	.O-RING .ANILLO O	1	1	
57	91318-04025	.BOLT .TORNILLO	1	1	
58	69J-43831-00	.CONNECTOR, SHAFT .CONEXION EJE	1	1	
59	93604-29184	.PIN, DOWEL .PASADOR DE CLAVIJA	2	2	
60	91318-05025	.BOLT .TORNILLO	1	1	
61	63P-43338-10	.WASHER, WAVE .ARANDELA ONDULADA	1	1	
62	6CJ-43816-00	FILTER 1 FILTRO 1	1	1	
63	63P-4381J-10	PLATE PLACA	1	1	
64	62Y-43871-00	RING, BACK UP ANILLO	1	1	
65	69J-43899-01	PLATE STOPPER PLACA	1	1	
66	93210-064A5	O-RING ANILLO O	4	4	
67	93501-08001	BALL BOLA	2	2	
68	63P-4385H-10	SPRING, SEAL RESORTE	1	1	
69	63P-4384G-10	SEAL, RELIEF VALVE ASIENTO	1	1	
70	63P-4388H-10	PLUG TAPON	2	2	
71	63P-43899-10	PLATE STOPPER PLACA	1	1	
72	61A-43878-00	BOLT, SOCKET TORNILLO ENCASTRE	1	1	
73	93505-32038	BALL BOLA	1	1	





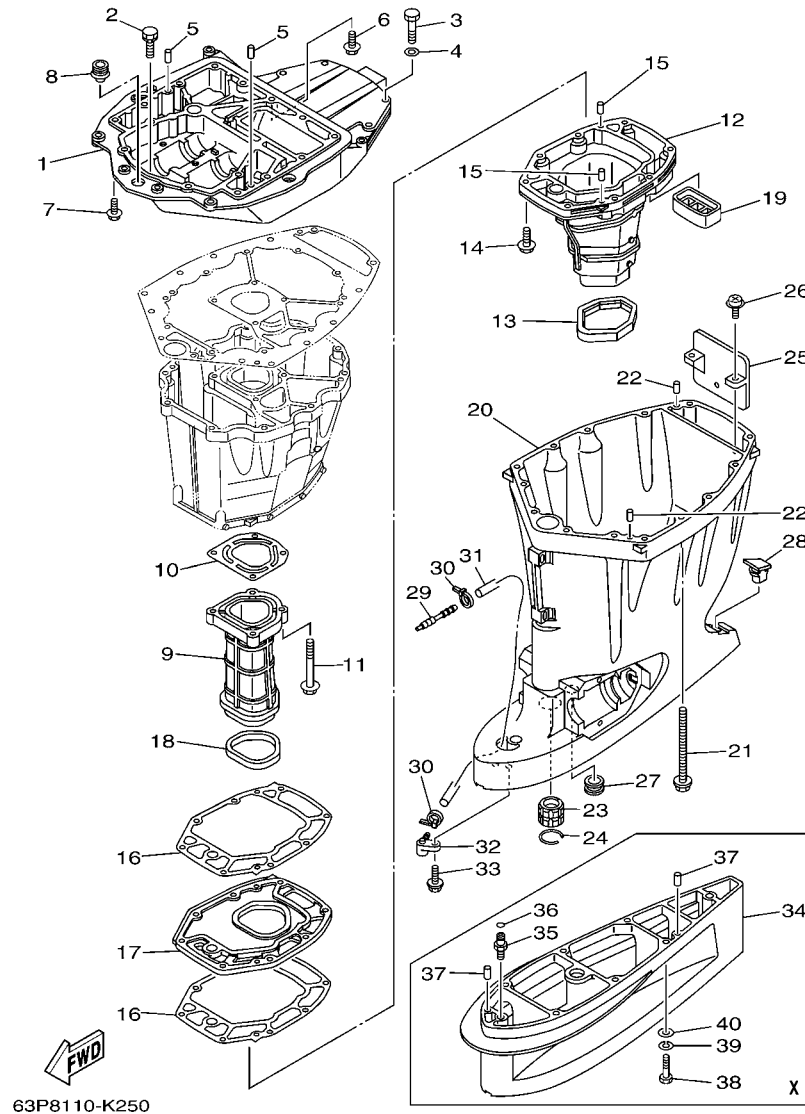


FIG. 25 UPPER CASING

FUNDA SUPERIOR

REF. NO.	PART NO. CODIGO Nº	DESCRIPTION DESCRIPCION	63P9	64P9	REMARKS OBSERVACIONES
1	63P-41137-02-CA	GUIDE, EXHAUST GUIA DE ESCAPE	1	1	
2	90119-08102	BOLT, WITH WASHER TORNILLO CON ARANDELA	2	2	
3	97075-10045	BOLT PERNO	4	4	
4	92995-10600	WASHER ARANDELA	4	4	
5	93608-16M16	PIN, DOWEL PASADOR DE CLAVIJA	2	2	
6	90119-08M58	BOLT, WITH WASHER TORNILLO CON ARANDELA	3	3	
7	97575-10535	BOLT, WITH WASHER PERNO CON ARANDELA	4	4	
8	6E5-42724-00	GROMMET TAPON	1	1	
9	63P-41131-01-9S	MANIFOLD, EXT. 1 TUBO MULTIPLE DE ESCAPE	1	1	
10	63P-41133-A0	GASKET, EXHAUST MANIFOLD 1 EMPAQUE ESCAPE MULTIPLE	1	1	
11	97575-08560	BOLT, WITH WASHER PERNO CON ARANDELA	4	4	
12	63P-14711-01-9S	MUFFLER 1 SILENCIADOR 1	1	1	
13	69J-45123-00	GASKET, MUFFLER EMPAQUE SILENCIADOR	1	1	
14	97575-08535	BOLT, WITH WASHER PERNO CON ARANDELA	8	8	
15	93606-19M23	PIN, DOWEL PASADOR DE CLAVIJA	2	2	
16	63P-41134-A0	GASKET, EXHAUST MANIFOLD EMPAQUE	2	2	
17	63P-45181-01-9S	PLATE PLACA	1	1	
18	63P-41138-00	SEAL, EXT. 1 SELLO, ESCAPE 1	1	1	
19	69J-45127-00	SEAL SELLO DE GOMA	1	1	
20	63P-45111-00-8D	CASING, UPPER CAJA SUPERIOR	1	1	
21	90119-10007	BOLT, WITH WASHER TORNILLO CON ARANDELA	8	8	
22	93608-16M16	PIN, DOWEL PASADOR DE CLAVIJA	2	2	
23	6E5-45318-00	BUSHING, DRIVE SHAFT BUJE, EJE DE MANDO	1	1	
24	93420-36M01	CIRCLIP SEGURO	1	1	
25	69J-14624-01	COVER, EXHAUST CUBIERTA ESCAPE	1	1	
26	97980-06216	SCREW, WITH WASHER TORNILLO, CON ARANDELA	2	2	
27	6E5-44366-00	DAMPER, WATER SEAL 2 GOMA DEL SELLO DE AGUA 2	1	1	

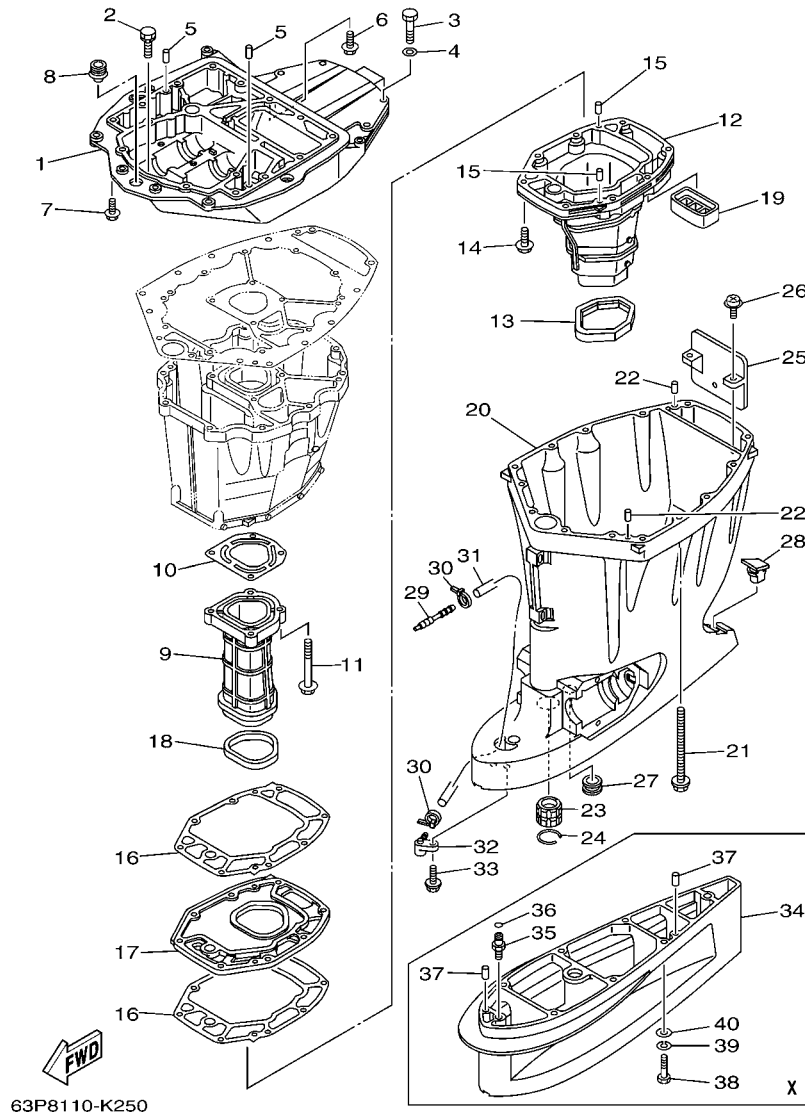
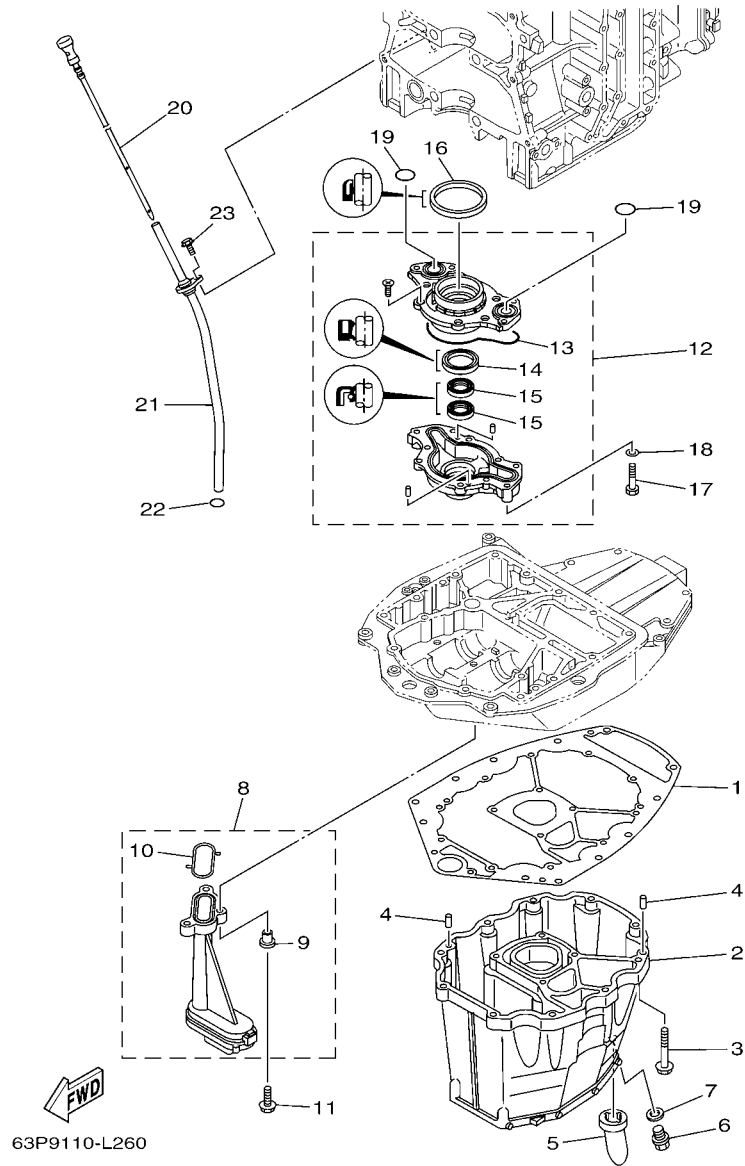


FIG. 25 UPPER CASING

FUNDA SUPERIOR

REF. NO.	PART NO. CODIGO Nº	DESCRIPTION DESCRIPCION	63P9	64P9	REMARKS OBSERVACIONES
28	6C5-45155-00	CAP TAPA	1	1	
29	6E5-83558-00	END, NIPPLE EXTREMO DE NIPLE	1	1	
30	90465-11M10	CLAMP BRIDA	2	2	
31	90445-070F1	HOSE (L950) TUBO (L950)	1	1	
32	63P-45379-00	NIPPLE, HOSE NIPLE DE MANGUERA	1	1	
33	90119-06M18	BOLT, WITH WASHER TORNILLO CON ARANDELA	1	1	
34	63P-45211-00-8D	EXTENSION EXTENSION	1	1	X(25.3") X(25.3")
35	63P-45378-00	NIPPLE, HOSE NIPLE MANGUERA	1	1	X(25.3") X(25.3")
36	93210-07003	O-RING ANILLO O	1	1	X(25.3") X(25.3")
37	93608-16M16	PIN, DOWEL PASADOR DE CLAVIJA	2	2	X(25.3") X(25.3")
38	97095-10045	BOLT PERNO	6	6	X(25.3") X(25.3")
39	92995-10100	WASHER ARANDELA	6	6	X(25.3") X(25.3")
40	92995-10600	WASHER ARANDELA	6	6	X(25.3") X(25.3")



63P9110-L260

FIG. 26 OIL PAN

OIL PAN

REF. NO.	PART NO. CODIGO Nº	DESCRIPTION DESCRIPCION	63P9	64P9	REMARKS OBSERVACIONES
1	63P-15312-00	GASKET, OIL PAN EMPAQ BANDEJA DE ACEITE	1	1	
2	63P-15311-02-CA	OIL PAN BANDEJA DE ACEITE	1	1	
3	97575-08535	BOLT, WITH WASHER PERNO CON ARANDELA	10	10	
4	93608-16M16	PIN, DOWEL PASADOR DE CLAVIJA	2	2	
5	63P-15316-00	DAMPER 1 AMORTIGUADOR 1	1	1	
6	90340-14M06	PLUG, STRAIGHT SCREW TORNILLO, DE DRENAJE	1	1	
7	90430-14M09	GASKET JUNTA	1	1	
8	63P-13411-00	STRAINER, OIL FILTRO DE ACEITE	1	1	
9	90387-06263	.COLLAR .ESPACIADOR	3	3	
10	63P-13415-00	.SEAL, OIL STRAINER .SELLO COLADOR ACEITE	1	1	
11	95812-06025	BOLT, FLANGE TORNILLO DE REBORDE	3	3	
12	63P-13300-02	OIL PUMP ASSY BOMBA DE ACEITE COMPLETA	1	1	
13	63P-13329-00	.GASKET, PUMP COVER .EMPAQUE TAPA DE BOMBA	1	1	
14	6AW-13119-00	.OIL SEAL .SELLO ACEITE	1	1	
15	69J-13631-00	.OIL SEAL .SELLO ACEITE	2	2	
16	69J-11355-00	SEAL, CYLINDER 1 RETEN ACEITE CILINDRO 1	1	1	
17	97095-06040	BOLT PERNO	4	4	
18	92995-06600	WASHER ARANDELA	4	4	
19	93210-25552	O-RING ANILLO O	2	2	
20	63P-15362-10	PLUG, OIL LEVEL TAPON DEL NIVEL DE ACEITE	1	1	
21	63P-15377-10	GUIDE, INLET GUIA DE ENTRADA	1	1	
22	93210-19MJ3	O-RING ANILLO O	1	1	
23	95895-06016	BOLT, FLANGE TORNILLO DE REBORDE	1	1	

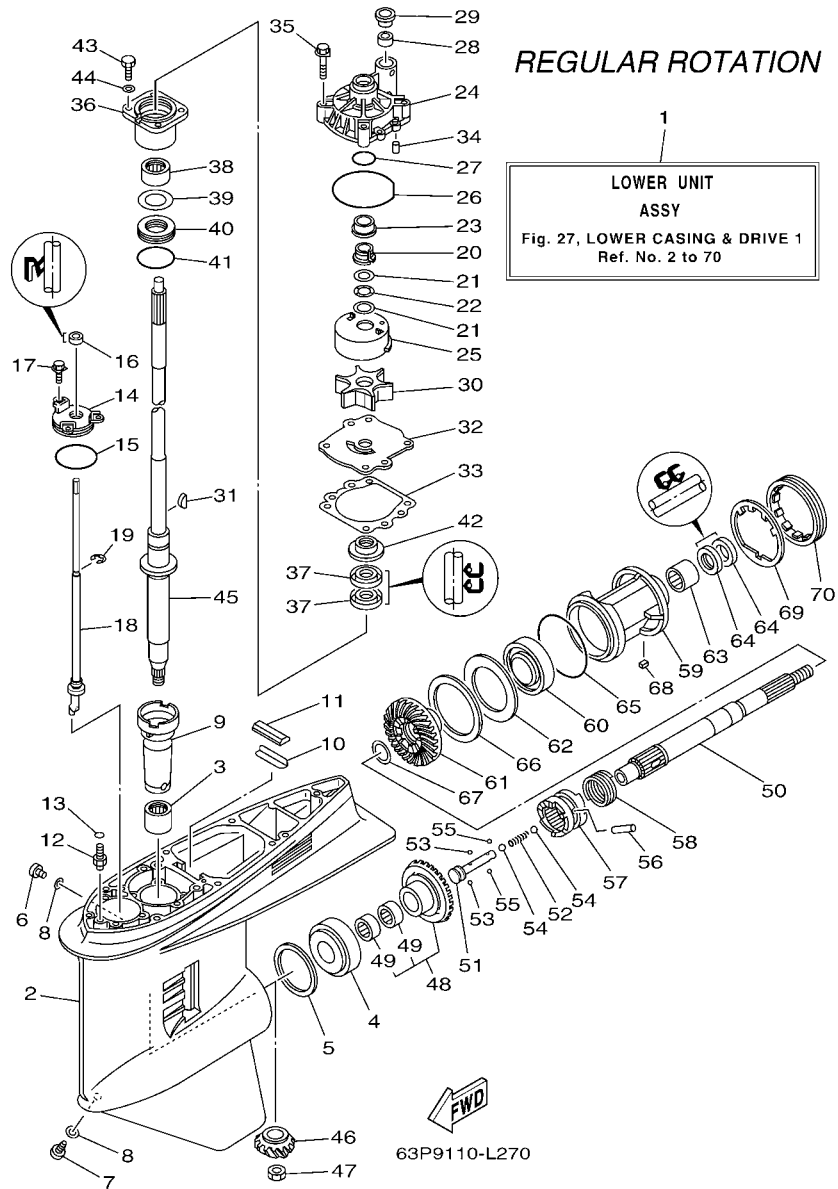


FIG. 27 LOWER CASING & DRIVE 1 IMPULSOR E INFERIOR 1

REF. NO.	PART NO. CODIGO Nº	DESCRIPTION DESCRIPCION	63P9	64P9		REMARKS OBSERVACIONES
1	63P-45300-03-8D	LOWER UNIT ASSY CONJUNTO UNIDAD INFERIOR	1			L(20.3"),RH L(20.3"),RH
	63P-45300-13-8D	LOWER UNIT ASSY CONJUNTO UNIDAD INFERIOR	1			X(25.3"),RH X(25.3"),RH
2	6J9-45301-07-8D	CASING, LOWER FUNDA INFERIOR COMPLETA	1			
3	93311-928U5	BEARING COJINETE DE RODILLOS	1			
4	93332-000V3	BEARING COJINETE	1			
5	6G5-45567-01	SHIM (T:0.10MM) LAINA (T:0.10MM)	1			UR UR
	6G5-45567-10	SHIM (T:0.12MM) LAINA (T:0.12MM)	1			UR UR
	6G5-45567-20	SHIM (T:0.15MM) LAINA (T:0.15MM)	1			UR UR
	6G5-45567-30	SHIM (T:0.18MM) LAINA (T:0.18MM)	1			UR UR
	6G5-45567-40	SHIM (T:0.30MM) LAINA (T:0.30MM)	1			UR UR
	6G5-45567-50	SHIM (T:0.40MM) LAINA (T:0.40MM)	1			UR UR
	6G5-45567-60	SHIM (T:0.50MM) LAINA (T:0.50MM)	1			UR UR
6	90340-08002	PLUG, STRAIGHT SCREW TORNILLO, DE DRENAJE	1			
7	688-45341-10	PLUG, DRAIN TAPON, DREN	1			
8	90430-08020	GASKET JUNTA	2			
9	6G5-45536-01	SLEEVE, DRIVE SHAFT CAMISA EJE DE MANDO	1			
10	663-45376-00	GUIDE, SEAL DAMPER GUIA DE SELLO GOMA	1			
11	688-45375-00	DAMPER, SEAL GOMA DE SELLO	1			
12	63P-45378-00	NIPPLE, HOSE NIPLE MANGUERA	1			
13	93210-07003	O-RING ANILLO O	1			
14	6E5-45321-00	PLATE PLACA	1			
15	93210-58144	O-RING ANILLO O	1			
16	93106-09014	OIL SEAL SELLO ACEITE	1			
17	90119-06M10	BOLT, WITH WASHER TORNILLO CON ARANDELA	3			
18	63P-44150-01	SHIFT CAM ASSY CONJUNTO EJE LEVA COMPL.	1			L(20.3"),RH L(20.3"),RH
	63P-44150-11	SHIFT CAM ASSY CONJUNTO EJE LEVA COMPL.	1			X(25.3"),RH X(25.3"),RH
19	99001-08600	CIRCLIP PRESILLA REDONDA	1			

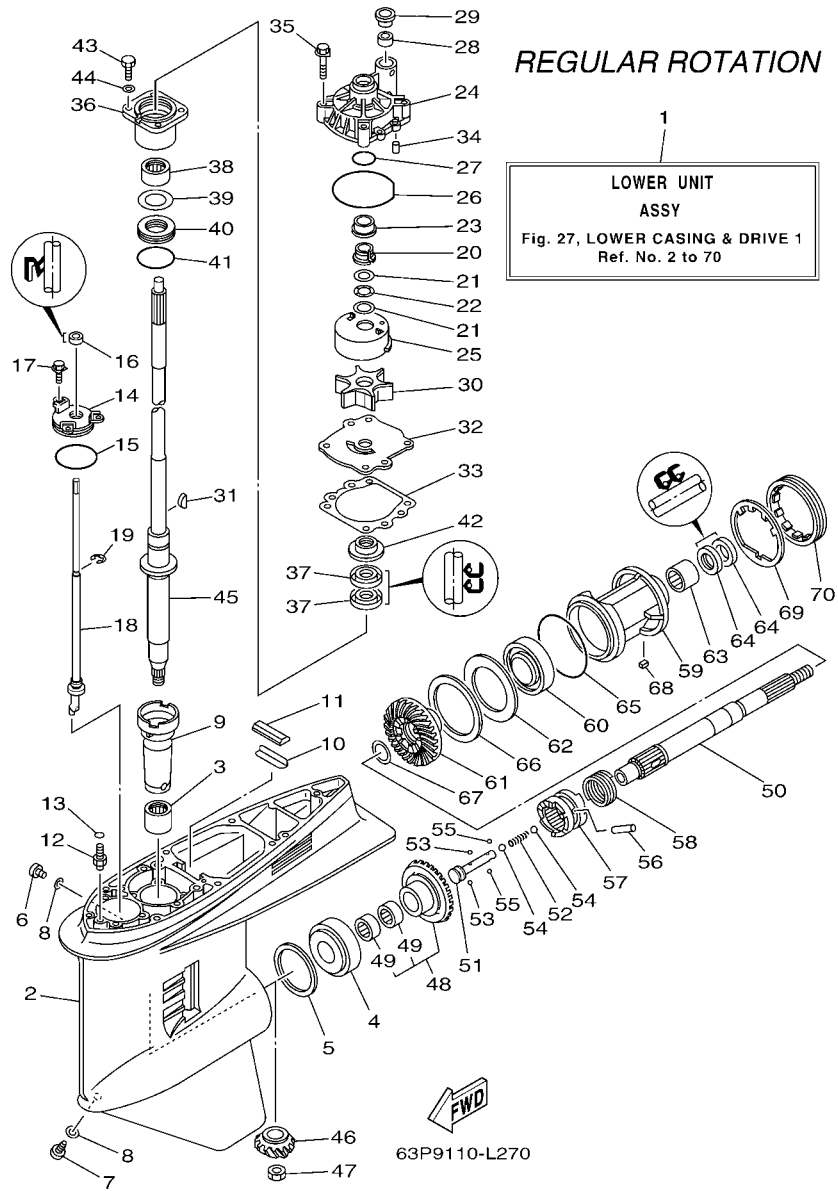


FIG. 27 LOWER CASING & DRIVE 1 IMPULSOR E INFERIOR 1

REF. NO.	PART NO. CODIGO Nº	DESCRIPTION DESCRIPCION	63P9	64P9	REMARKS OBSERVACIONES
20	61A-45538-00	SPACER 1 ESPACIADOR 1	1		
21	90201-22M01	WASHER, PLATE ARANDELA PLANA	2		
22	90206-22M19	WASHER, WAVE ARANDELA ONDULADA	1		
23	61A-45527-00	COLLAR, DRIVE SHAFT COLLAR EJE FLECHA DE PROPULSION	1		
24	61A-44311-01	HOUSING, WATER PUMP CAJA BOMBA DE AGUA	1		
25	61A-44322-02	INSERT, CARTRIDGE CARTUCHO	1		
26	93210-86M38	O-RING ANILLO O	1		
27	93210-37160	O-RING ANILLO O	1		
28	6E5-44365-00	DAMPER, WATER SEAL 1 HULE DE SELLO DE AGUA 1	1		
29	6E5-44312-00	COVER, WATER PUMP HOUSING CUBIERTA CAJA BOMBA DE AGUA	1		
30	6E5-44352-01	IMPELLER IMPULSOR	1		
31	90280-04M05	KEY, WOODRUFF CUNA WOODRUFF	1		
32	6G5-44323-00	OUTER PLATE, CARTRIDGE PLACA EXTERIOR DEL CARTUCHO	1		
33	6E5-44315-A0	GASKET, WATER PUMP EMPAQUE	1		
34	93606-12019	PIN, DOWEL PASADOR DE CLAVIJA	2		
35	90119-08M14	BOLT, WITH WASHER TORNILLO CON ARANDELA	4		
36	6E5-45331-00-9S	HOUSING, BEARING CAJA DE COJINETE	1		
37	93101-28M16	OIL SEAL SELLO ACEITE	2		
38	93317-330U2	BEARING COJINETE	1		
39	6E5-45587-01	SHIM (T:0.10MM) LAINA (T:0.10MM)	1		UR
	6E5-45587-10	SHIM (T:0.12MM) LAINA (T:0.12MM)	1		UR
	6E5-45587-20	SHIM (T:0.15MM) LAINA (T:0.15MM)	1		UR
	6E5-45587-30	SHIM (T:0.18MM) LAINA (T:0.18MM)	1		UR
	6E5-45587-40	SHIM (T:0.30MM) LAINA (T:0.30MM)	1		UR
	6E5-45587-50	SHIM (T:0.40MM) LAINA (T:0.40MM)	1		UR
	6E5-45587-60	SHIM (T:0.50MM) LAINA (T:0.50MM)	1		UR
40	93341-930V2	BEARING COJINETES CON RODAMIENTOS	1		

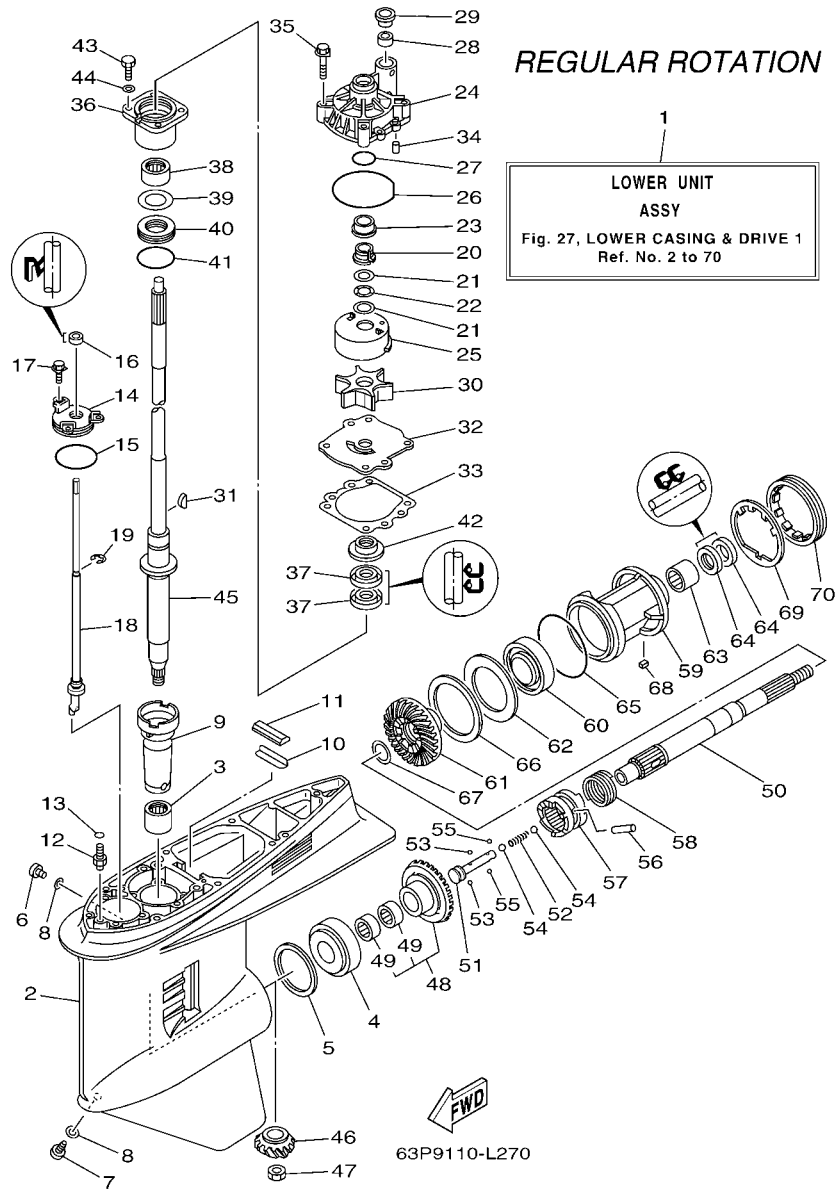


FIG. 27 LOWER CASING & DRIVE 1 IMPULSOR E INFERIOR 1

REF. NO.	PART NO. CODIGO Nº	DESCRIPTION DESCRIPCION	63P9	64P9		REMARKS OBSERVACIONES
41	93210-55M14	O-RING ANILLO O	1			
42	6E5-45344-00	COVER, OIL SEAL CUBIERTA SELLO ACEITE	1			
43	97095-08025	BOLT PERNO	4			
44	92995-08600	WASHER ARANDELA	4			
45	63P-45501-00	DRIVE SHAFT COMP. EJE DE MANDO COMPL.	1			L(20.3") L(20.3")
	63P-45501-10	DRIVE SHAFT COMP. EJE DE MANDO COMPL.	1			X(25.3") X(25.3")
46	63P-45551-00	PINION (14T) PINON (14T)	1			
47	90170-16M01	NUT TUERCA	1			
48	63P-45560-02	GEAR 1 (28T) ENGRANAJE 1 (28T)	1			
49	93315-425V3	BEARING COJINETE DE RODILLOS	2			
50	6J9-45611-01	SHAFT, PROPELLER EJE PROPUSOR	1			
51	6E5-45634-02	SLIDE, SHIFT DESLIZADOR, CAMBIO	1			
52	90501-16M37	SPRING, COMPRESSION RESORTE DE COMPRESION	1			
53	93507-32009	BALL ESFERA	2			
54	93511-32017	BALL ESFERA	2			
55	93503-16003	BALL ESFERA	2			
56	90250-08M07	PIN, STRAIGHT PASADOR CILINDRICO	1			
57	63P-45631-11	CLUTCH, DOG EMBRAGUE DE GARRA	1			
58	6E5-45633-01	RING, CROSS PIN ANILLO DE PASADOR	1			
59	6J9-45332-00-CA	HOUSING, BEARING CAJA BALERO 2	1			
60	93306-209U0	BEARING COJINETE	1			
61	63P-45571-02	GEAR 2 (28T) ENGRANAJE 2 (28T)	1			
62	6G5-45576-10	WASHER, THRUST 2 ARANDELA DE EMPUJE AXIAL 2	1			
63	93315-43061	BEARING COJINETE DE RODILLOS	1			
64	93101-30M17	OIL SEAL SELLO ACEITE	2			
65	93210-97M55	O-RING ANILLO O	1			
66	6G5-45577-02	SHIM (T:0.10MM) LAINA (T:0.10MM)	1			UR UR

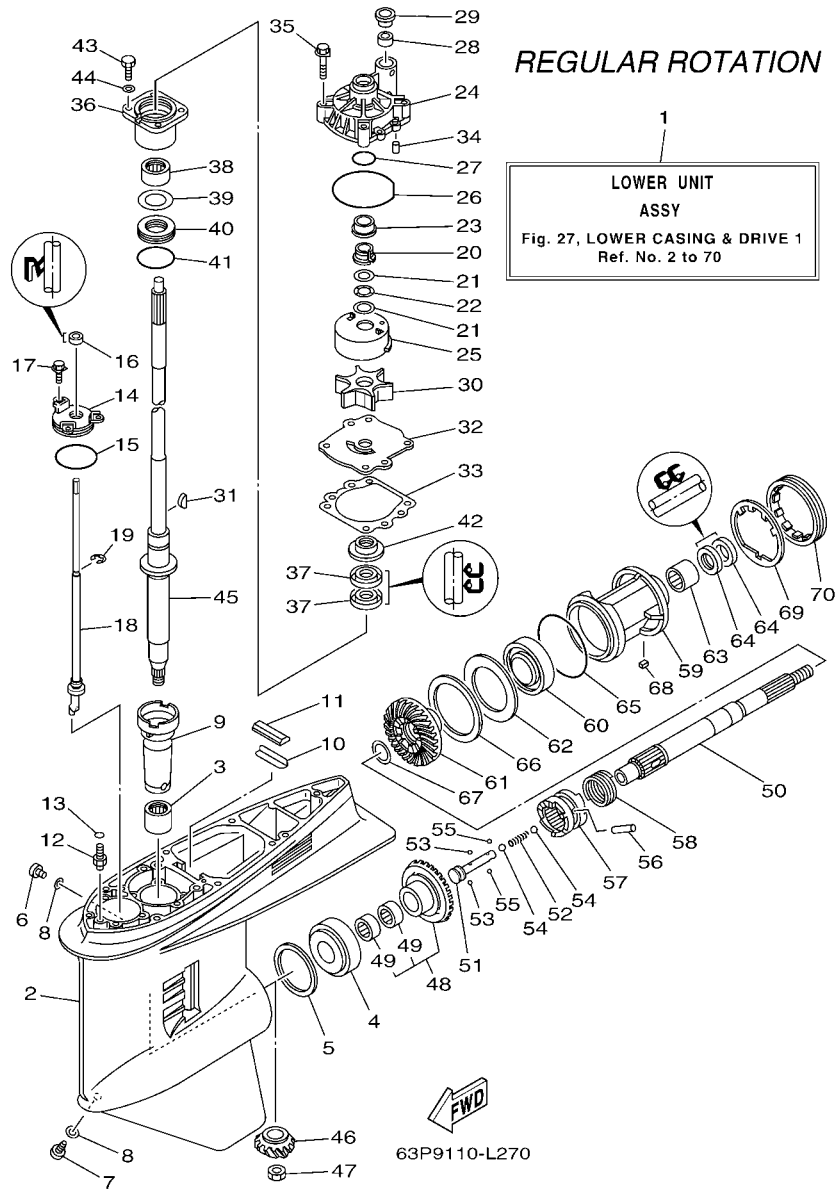
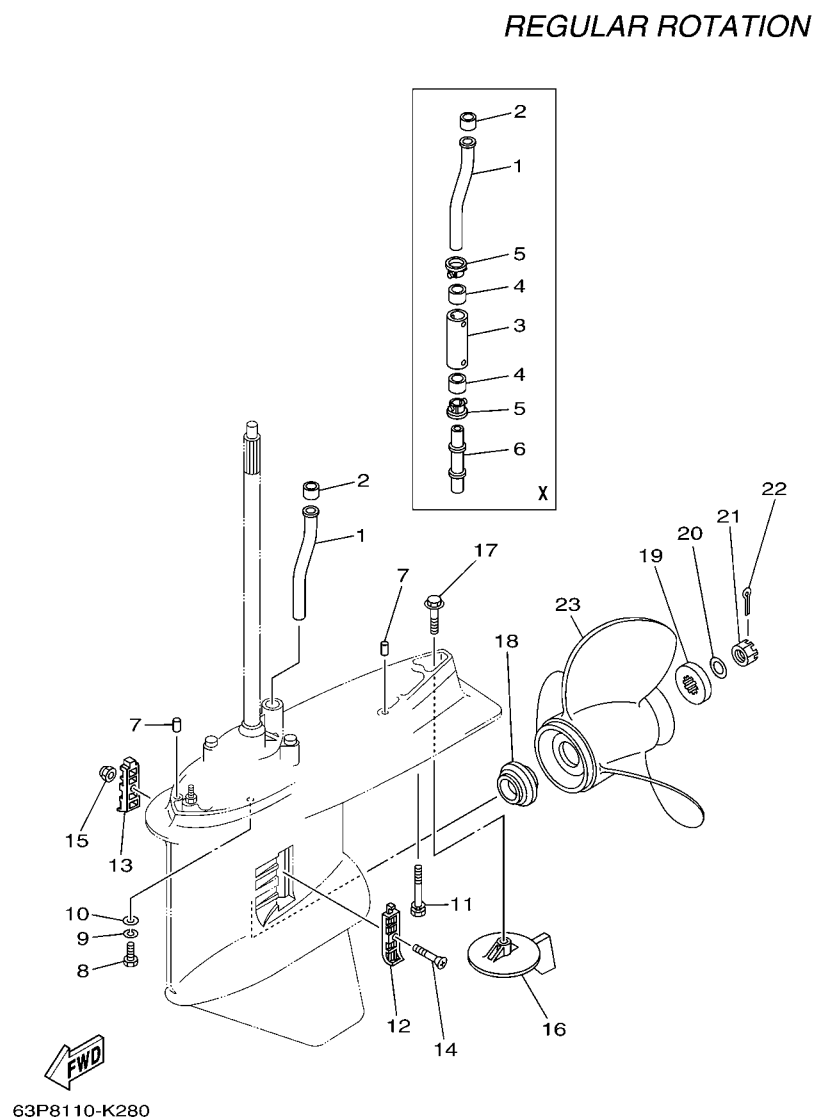


FIG. 27 LOWER CASING & DRIVE 1 IMPULSOR E INFERIOR 1

REF. NO.	PART NO. CODIGO Nº	DESCRIPTION DESCRIPCION	63P9	64P9	REMARKS OBSERVACIONES
66	6G5-45577-10	SHIM (T:0.12MM) LAINA (T:0.12MM)	1		UR UR
	6G5-45577-20	SHIM (T:0.15MM) LAINA (T:0.15MM)	1		UR UR
	6G5-45577-30	SHIM (T:0.18MM) LAINA (T:0.18MM)	1		UR UR
	6G5-45577-40	SHIM (T:0.30MM) LAINA (T:0.30MM)	1		UR UR
	6G5-45577-50	SHIM (T:0.40MM) LAINA (T:0.40MM)	1		UR UR
	6G5-45577-60	SHIM (T:0.50MM) LAINA (T:0.50MM)	1		UR UR
67	90201-30M92	WASHER, PLATE ARANDELA PLANA	1		
68	90282-04M00	KEY, STRAIGHT CHAVETA, RECTA	1		
69	6G5-45383-01	WASHER, CLAW ARANDELA DE UNA	1		
70	6G5-45384-02	NUT TUERCA	1		

FIG. 28 LOWER CASING & DRIVE 2

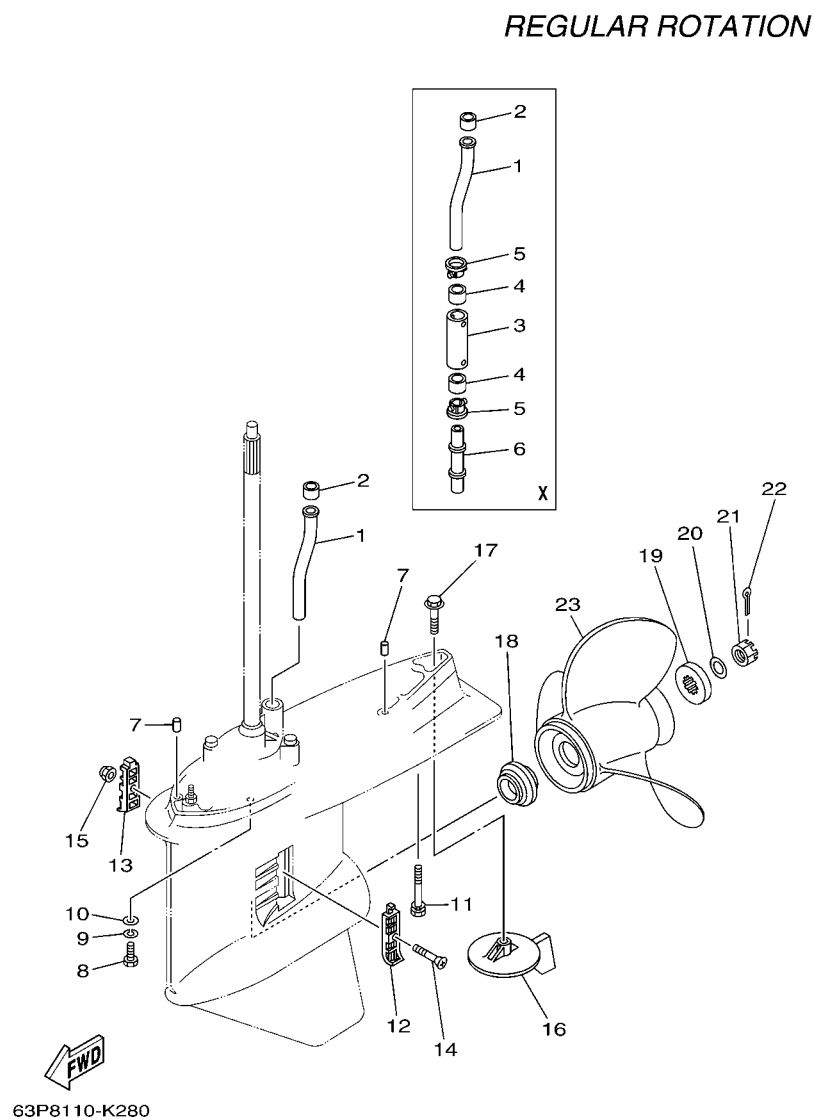
IMPULSOR E INFERIOR 2



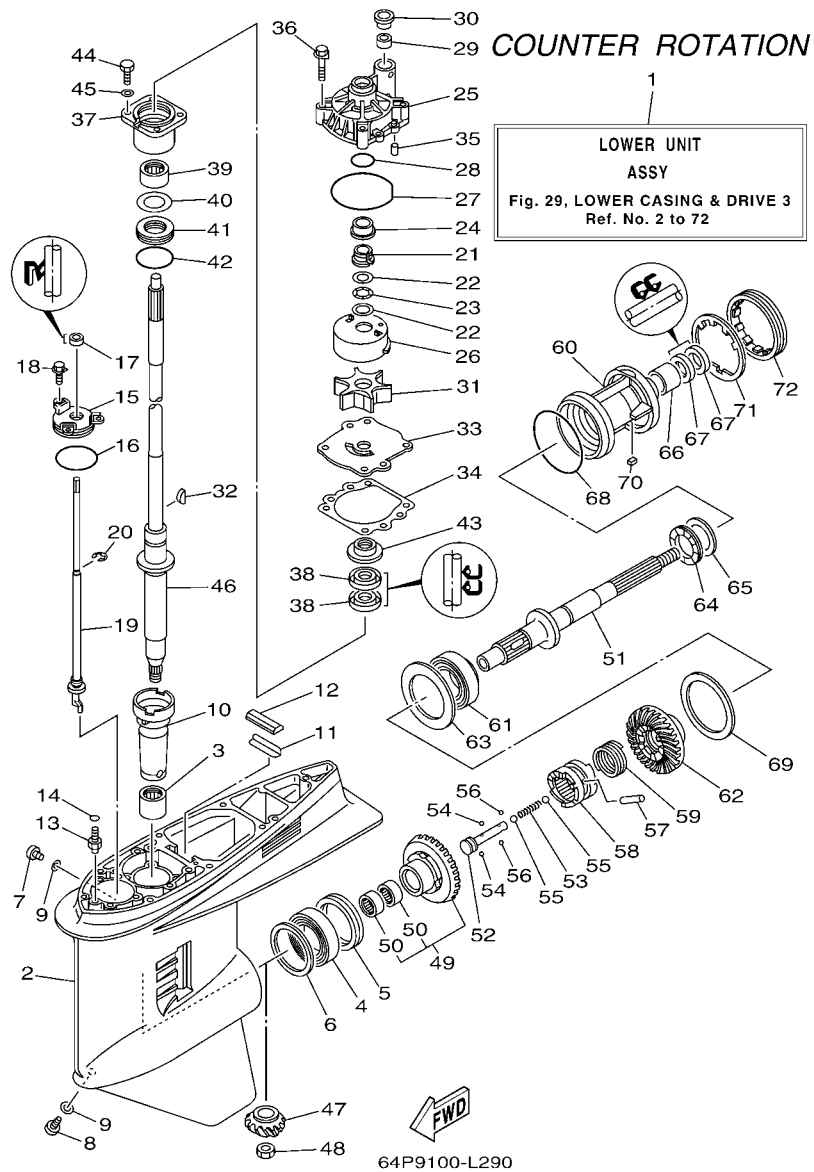
REF. NO.	PART NO. CODIGO Nº	DESCRIPTION DESCRIPCION	63P9	64P9		REMARKS OBSERVACIONES
1	63P-44361-00	TUBE, WATER 1 TUBO DE AGUA 1	1			
2	6E5-44365-00	DAMPER, WATER SEAL 1 HULE DE SELLO DE AGUA 1	1			
3	63P-44362-00	TUBE, WATER 2 TUBO DE AGUA 2	1			X(25.3") X(25.3")
4	6E5-44365-00	DAMPER, WATER SEAL 1 HULE DE SELLO DE AGUA 1	2			X(25.3") X(25.3")
5	6E5-44312-00	COVER, WATER PUMP HOUSING CUBIERTA CAJA BOMBA DE AGUA	2			X(25.3") X(25.3")
6	63P-44363-00	TUBE, WATER 3 TUBO DE AGUA 3	1			X(25.3") X(25.3")
7	93608-16M16	PIN, DOWEL PASADOR DE CLAVIJA	2			
8	97095-10045	BOLT PERNO	6			
9	92995-10100	WASHER ARANDELA	6			
10	92995-10600	WASHER ARANDELA	6			
11	90119-10MA2	BOLT, WITH WASHER TORNILLO CON ARANDELA	1			L(20.3") L(20.3")
	90119-10008	BOLT, WITH WASHER TORNILLO CON ARANDELA	1			X(25.3") X(25.3")
12	6J9-45214-00	COVER, WATER INLET 1 CUBIERTA ENTRADA AGUA 1	1			
13	6J9-45215-00	COVER, WATER INLET 2 CUBIERTA ENTRADA AGUA 2	1			
14	90152-05M08	SCREW, COUNTERSUNK TORNILLO EMBUTIDO	1			
15	90185-05002	NUT, NYLON TUERCA AUTOBLOCANTE	1			
16	6J9-45371-01	TAB-TRIM QUILLA ESTABILIZADOR	1			
17	90105-10M00	BOLT, FLANGE TORNILLO	1			
18	63P-45987-00	SPACER 1 ESPACIADOR 1	1			
19	688-45997-01	SPACER 2 ESPACIADOR 2	1			
20	92990-18200	WASHER ARANDELA PLANA	1			
21	90171-18M04	NUT, CASTLE TUERCA ENTALLADA	1			
22	91490-40030	PIN, COTTER CHAVETA	1			
23	6G5-45941-00	PROPELLER (3X15-1/4"X15"-M) PROPELA (3X15-1/4"X15"-M)	1			UR UR
	6G5-45943-01	PROPELLER (3X13-3/4"X21"-M) PROPELA (3X13-3/4"X21"-M)	1			UR UR
	6G5-45945-01	PROPELLER (3X14"X19"-M) PROPELA (3X14"X19"-M)	1			UR UR
	6G5-45947-01	PROPELLER (3X14-1/2"X17"-M) PROPELA (3X14-1/2"X17"-M)	1			UR UR



FIG. 28 LOWER CASING & DRIVE 2 IMPULSOR E INFERIOR 2

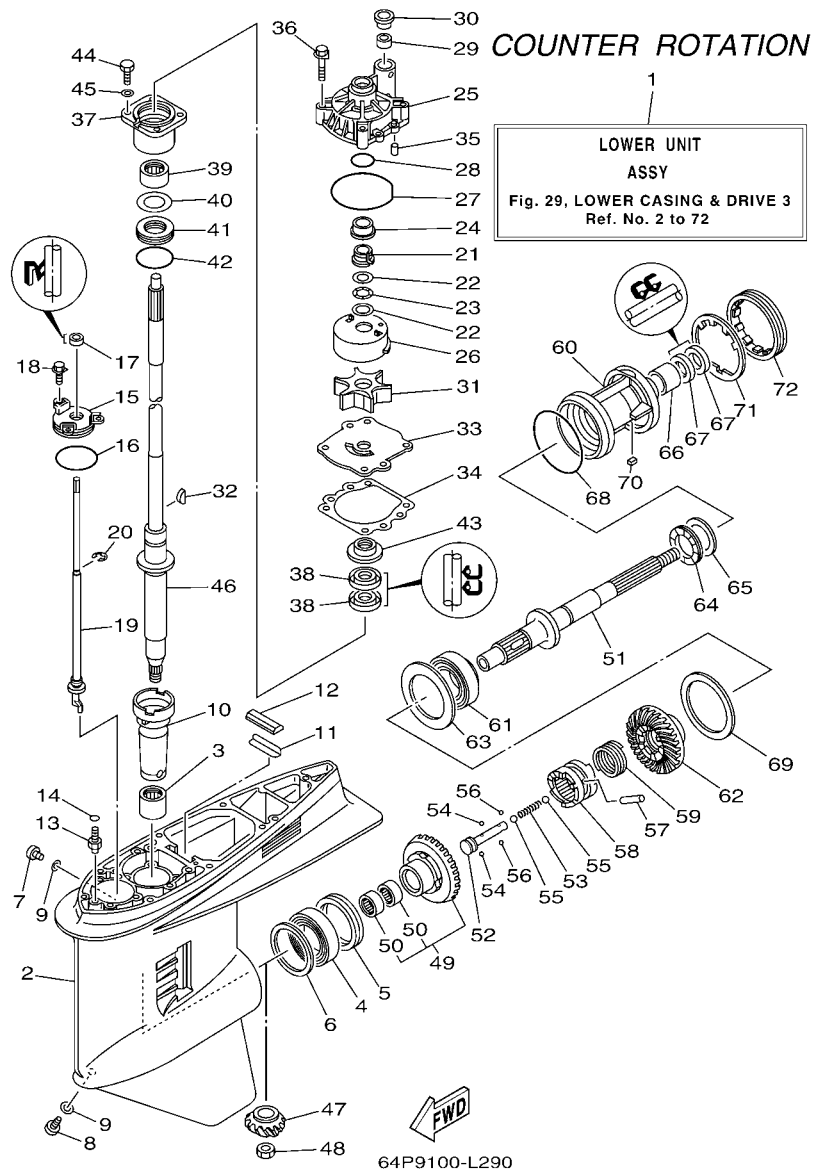


REF. NO.	PART NO. CODIGO Nº	DESCRIPTION DESCRIPCION	63P9	64P9		REMARKS OBSERVACIONES
23	6G5-45949-00	PROPELLER (3X13-1/2"X23"-M) PROPELA (3X13-1/2"X23"-M)	1			UR UR
	6G5-45930-00	PROPELLER (3X13-3/8"X25"-M) PROPELA (3X13-3/8"X25"-M)	1			UR UR
	6G5-45932-00	PROPELLER (3X15-3/4"X13"-M) PROPELA (3X15-3/4"X13"-M)	1			UR UR
	6G5-45970-02	PROPELLER (3X15-1/4"X15"-M) PROPELA (3X15-1/4"X15"-M)	1			UR UR
	6G5-45972-02	PROPELLER (3X13-3/4"X21"-M) PROPELA (3X13-3/4"X21"-M)	1			UR UR
	6G5-45974-03	PROPELLER (3X13-3/4"X19"-M2) PROPELA (3X13-3/4"X19"-M2)	1			UR UR
	6G5-45976-01	PROPELLER (3X13-3/8"X23"-M) PROPELA (3X13-3/8"X23"-M)	1			UR UR
	6G5-45978-03	PROPELLER (3X13-3/4"X17"-M2) PROPELA (3X13-3/4"X17"-M2)	1			UR UR
	6R4-45970-A1	PROPELLER (3X15-1/4"X19"-M) PROPELA (3X15-1/4"X19"-M)	1			UR UR
	6R4-45972-A0	PROPELLER (3X14-7/8"X21"-M) PROPELA (3X14-7/8"X21"-M)	1			UR UR
	6R4-45974-A0	PROPELLER (3X14-1/2"X23"-M) PROPELA (3X14-1/2"X23"-M)	1			UR UR
	6R4-45976-A0	PROPELLER (3X14-1/2"X15"-M) PROPELA (3X14-1/2"X15"-M)	1			UR UR
	6R4-45978-A0	PROPELLER (3X15-1/4"X17"-M) PROPELA (3X15-1/4"X17"-M)	1			UR UR
	66K-45970-B0	PROPELLER (3X14-1/2"X27"-M1) PROPELA (3X14-1/2"X27"-M1)	1			UR UR
	66K-45972-B0	PROPELLER (3X14-1/2"X25"-M2) PROPELA (3X14-1/2"X25"-M2)	1			UR UR
	66K-45974-B0	PROPELLER (3X14-1/2"X23"-M2) PROPELA (3X14-1/2"X23"-M2)	1			UR UR
	6J9-45976-10	PROPELLER (3X14-1/2"X21"-M1) PROPELA (3X14-1/2"X21"-M1)	1			UR UR



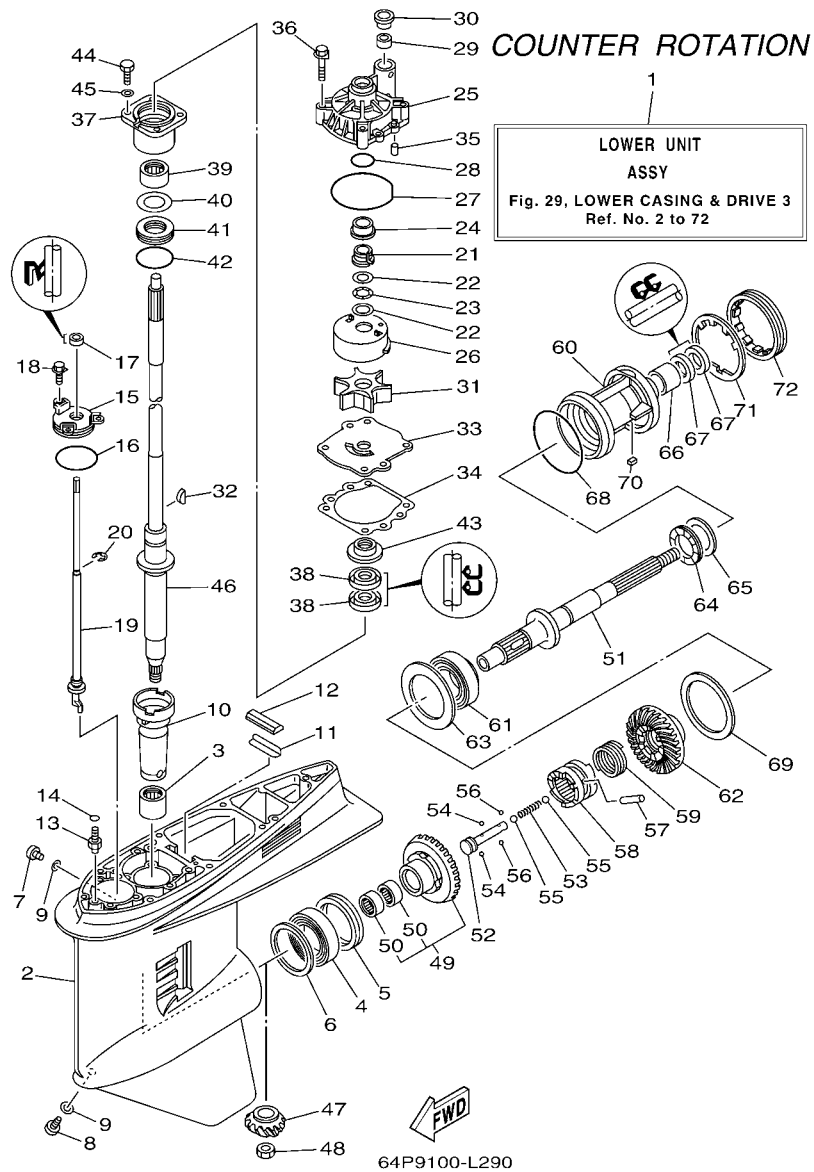
**FIG. 29 LOWER CASING & DRIVE 3 IMPULSOR E INFERIOR 3**

REF. NO.	PART NO. CODIGO Nº	DESCRIPTION DESCRIPCION	63P9	64P9	REMARKS OBSERVACIONES
1	64P-45300-12-8D	LOWER UNIT ASSY CONJUNTO UNIDAD INFERIOR		1	X(25.3"),LH X(25.3"),LH
2	6J9-45301-07-8D	CASING, LOWER FUNDA INFERIOR COMPLETA		1	
3	93311-928U5	BEARING COJINETE DE RODILLOS		1	
4	93390-000U2	BEARING COJINETE DE RODILLOS		1	
5	93341-465U4	BEARING COJINETES CON RODAMIENTOS		1	
6	6G5-45567-01	SHIM (T:0.10MM) LAINA (T:0.10MM)		1	UR
	6G5-45567-10	SHIM (T:0.12MM) LAINA (T:0.12MM)		1	UR
	6G5-45567-20	SHIM (T:0.15MM) LAINA (T:0.15MM)		1	UR
	6G5-45567-30	SHIM (T:0.18MM) LAINA (T:0.18MM)		1	UR
	6G5-45567-40	SHIM (T:0.30MM) LAINA (T:0.30MM)		1	UR
	6G5-45567-50	SHIM (T:0.40MM) LAINA (T:0.40MM)		1	UR
	6G5-45567-60	SHIM (T:0.50MM) LAINA (T:0.50MM)		1	UR
7	90340-08002	PLUG, STRAIGHT SCREW TORNILLO, DE DRENAJE		1	
8	688-45341-10	PLUG, DRAIN TAPON, DREN		1	
9	90430-08020	GASKET JUNTA		2	
10	6G5-45536-01	SLEEVE, DRIVE SHAFT CAMISA EJE DE MANDO		1	
11	663-45376-00	GUIDE, SEAL DAMPER GUIA DE SELLO GOMA		1	
12	688-45375-00	DAMPER, SEAL GOMA DE SELLO		1	
13	63P-45378-00	NIPPLE, HOSE NIPLE MANGUERA		1	
14	93210-07003	O-RING ANILLO O		1	
15	6E5-45321-00	PLATE PLACA		1	
16	93210-58144	O-RING ANILLO O		1	
17	93106-09014	OIL SEAL SELLO ACEITE		1	
18	90119-06M10	BOLT, WITH WASHER TORNILLO CON ARANDELA		3	
19	64P-44150-11	SHIFT CAM ASSY CONJUNTO EJE LEVA COMPL.		1	X(25.3"),LH X(25.3"),LH
20	99001-08600	CIRCLIP PRESILLA REDONDA		1	
21	61A-45538-00	SPACER 1 ESPACIADOR 1		1	



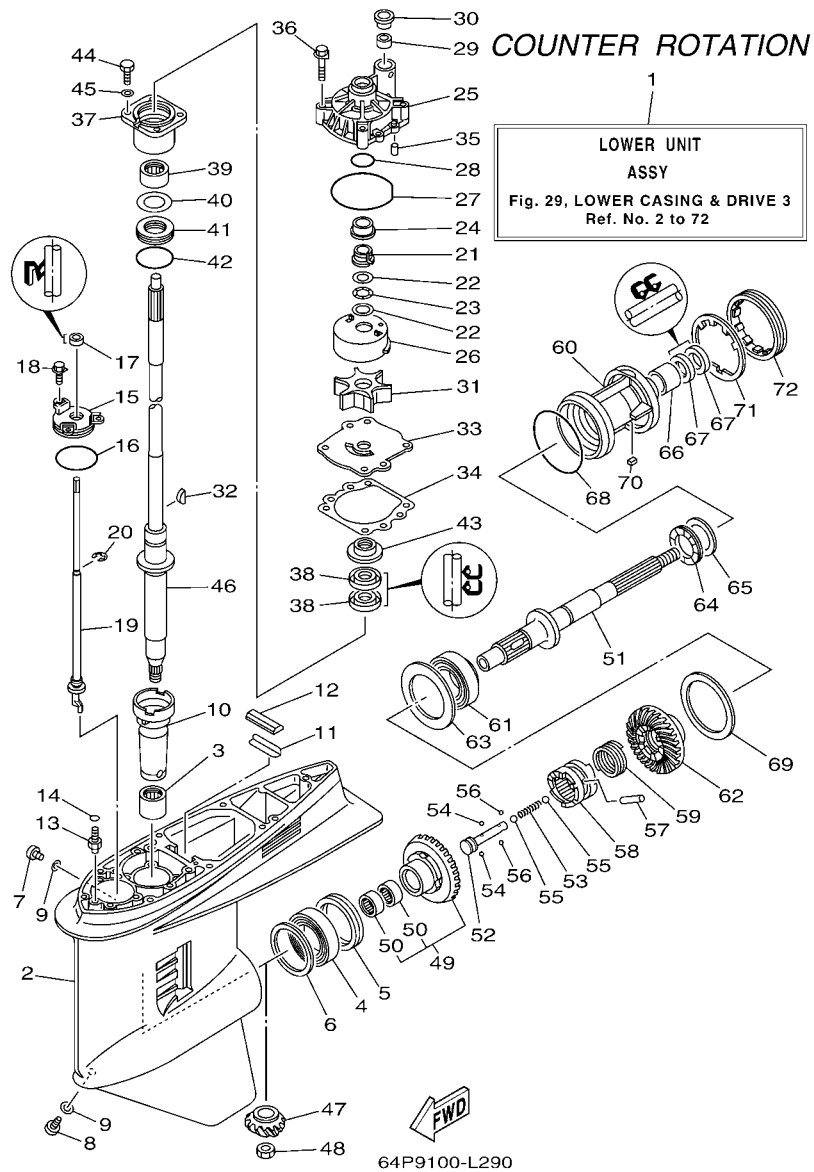
**FIG. 29 LOWER CASING & DRIVE 3 IMPULSOR E INFERIOR 3**

REF. NO.	PART NO. CODIGO Nº	DESCRIPTION DESCRIPCION	63P9	64P9	REMARKS OBSERVACIONES
22	90201-22M01	WASHER, PLATE ARANDELA PLANA		2	
23	90206-22M19	WASHER, WAVE ARANDELA ONDULADA		1	
24	61A-45527-00	COLLAR, DRIVE SHAFT COLLAR EJE FLECHA DE PROPULSION		1	
25	61A-44311-01	HOUSING, WATER PUMP CAJA BOMBA DE AGUA		1	
26	61A-44322-02	INSERT, CARTRIDGE CARTUCHO		1	
27	93210-86M38	O-RING ANILLO O		1	
28	93210-37160	O-RING ANILLO O		1	
29	6E5-44365-00	DAMPER, WATER SEAL 1 HULE DE SELLO DE AGUA 1		1	
30	6E5-44312-00	COVER, WATER PUMP HOUSING CUBIERTA CAJA BOMBA DE AGUA		1	
31	6E5-44352-01	IMPELLER IMPULSOR		1	
32	90280-04M05	KEY, WOODRUFF CUNA WOODRUFF		1	
33	6G5-44323-00	OUTER PLATE, CARTRIDGE PLACA EXTERIOR DEL CARTUCHO		1	
34	6E5-44315-A0	GASKET, WATER PUMP EMPAQUE		1	
35	93606-12019	PIN, DOWEL PASADOR DE CLAVIJA		2	
36	90119-08M14	BOLT, WITH WASHER TORNILLO CON ARANDELA		4	
37	6E5-45331-00-9S	HOUSING, BEARING CAJA DE COJINETE		1	
38	93101-28M16	OIL SEAL SELLO ACEITE		2	
39	93317-330U2	BEARING COJINETE		1	
40	6E5-45587-01	SHIM (T:0.10MM) LAINA (T:0.10MM)		1	UR
	6E5-45587-10	SHIM (T:0.12MM) LAINA (T:0.12MM)		1	UR
	6E5-45587-20	SHIM (T:0.15MM) LAINA (T:0.15MM)		1	UR
	6E5-45587-30	SHIM (T:0.18MM) LAINA (T:0.18MM)		1	UR
	6E5-45587-40	SHIM (T:0.30MM) LAINA (T:0.30MM)		1	UR
	6E5-45587-50	SHIM (T:0.40MM) LAINA (T:0.40MM)		1	UR
	6E5-45587-60	SHIM (T:0.50MM) LAINA (T:0.50MM)		1	UR
41	93341-930V2	BEARING COJINETES CON RODAMIENTOS		1	
42	93210-55M14	O-RING ANILLO O		1	



**FIG. 29 LOWER CASING & DRIVE 3 IMPULSOR E INFERIOR 3**

REF. NO.	PART NO. CODIGO Nº	DESCRIPTION DESCRIPCION	63P9	64P9	REMARKS OBSERVACIONES
43	6E5-45344-00	COVER, OIL SEAL CUBIERTA SELLO ACEITE		1	
44	97095-08025	BOLT PERNO		4	
45	92995-08600	WASHER ARANDELA		4	
46	63P-45501-10	DRIVE SHAFT COMP. EJE DE MANDO COMPL.		1	X(25.3")
47	63P-45551-00	PINION (14T) PINON (14T)		1	X(25.3")
48	90170-16M01	NUT TUERCA		1	
49	64P-45560-01	GEAR 1 (28T) ENGRANAJE 1 (28T)		1	
50	93315-425V3	.BEARING .COJINETE DE RODILLOS		2	
51	6K1-45611-10	SHAFT, PROPELLER EJE PROPUSOR		1	
52	6E5-45634-02	SLIDE, SHIFT DESLIZADOR, CAMBIO		1	
53	90501-16M37	SPRING, COMPRESSION RESORTE DE COMPRESION		1	
54	93507-32009	BALL ESFERA		2	
55	93511-32017	BALL ESFERA		2	
56	93503-16003	BALL ESFERA		2	
57	90250-08M07	PIN, STRAIGHT PASADOR CILINDRICO		1	
58	63P-45631-01	CLUTCH, DOG EMBRAGUE DE GARRA		1	
59	6E5-45633-01	RING, CROSS PIN ANILLO DE PASADOR		1	
60	6K1-45332-01-CA	HOUSING, BEARING CAJA BALERO 2		1	
61	93332-00048	BEARING COJINETE		1	
62	64P-45570-01	GEAR 2 (28T) ENGRANAJE 2 (28T)		1	
63	6K1-45576-00	WASHER, THRUST 2 ARANDELA DE EMPUJE AXIAL 2		1	
64	93341-440U5	BEARING COJINETES CON RODAMIENTOS		1	
65	6K1-45578-01	SHIM (T:0.10MM) LAINA (T:0.10MM)		1	UR
	6K1-45578-10	SHIM (T:0.12MM) LAINA (:0.12MM)		1	UR
	6K1-45578-20	SHIM (T:0.15MM) LAINA (T:0.15MM)		1	UR
	6K1-45578-30	SHIM (T:0.18MM) LAINA (T:0.18MM)		1	UR
	6K1-45578-40	SHIM (T:0.30MM) LAINA (T:0.30MM)		1	UR

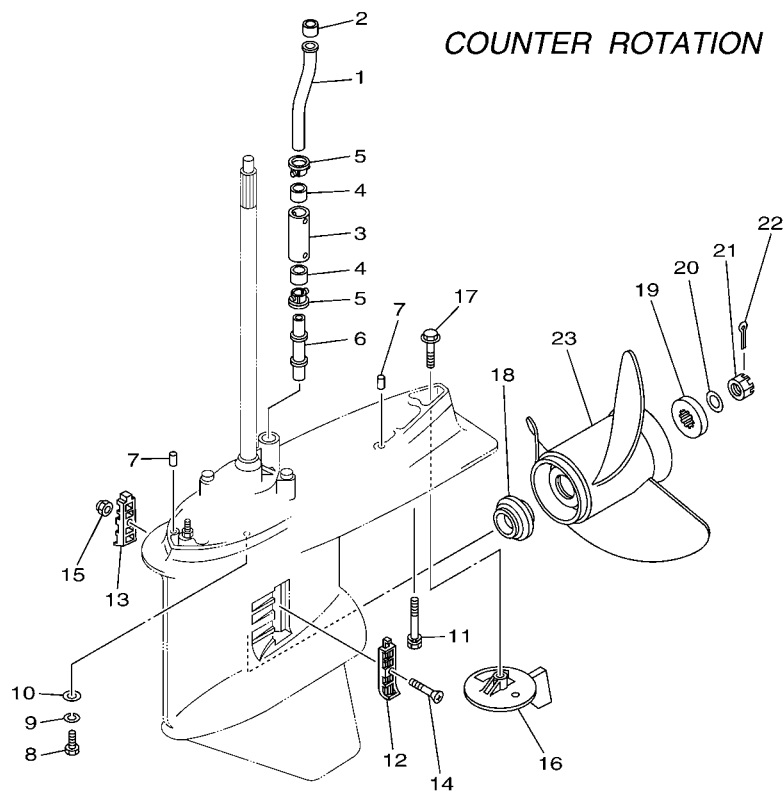


**FIG. 29 LOWER CASING & DRIVE 3 IMPULSOR E INFERIOR 3**

REF. NO.	PART NO. CODIGO Nº	DESCRIPTION DESCRIPCION	63P9	64P9	REMARKS OBSERVACIONES
65	6K1-45578-50	SHIM (T:0.40MM) LAINA (T:0.40MM)		1	UR UR
	6K1-45578-60	SHIM (T:0.50MM) LAINA (T:0.50MM)		1	UR UR
66	93315-43061	BEARING COJINETE DE RODILLOS		1	
67	93101-30M17	OIL SEAL SELLO ACEITE		2	
68	93210-97M55	O-RING ANILLO O		1	
69	6G5-45577-02	SHIM (T:0.10MM) LAINA (T:0.10MM)		1	UR UR
	6G5-45577-10	SHIM (T:0.12MM) LAINA (T:0.12MM)		1	UR UR
	6G5-45577-20	SHIM (T:0.15MM) LAINA (T:0.15MM)		1	UR UR
	6G5-45577-30	SHIM (T:0.18MM) LAINA (T:0.18MM)		1	UR UR
	6G5-45577-40	SHIM (T:0.30MM) LAINA (T:0.30MM)		1	UR UR
	6G5-45577-50	SHIM (T:0.40MM) LAINA (T:0.40MM)		1	UR UR
	6G5-45577-60	SHIM (T:0.50MM) LAINA (T:0.50MM)		1	UR UR
70	90282-04M00	KEY, STRAIGHT CHAVETA, RECTA		1	
71	6G5-45383-01	WASHER, CLAW ARANDELA DE UNA		1	
72	6G5-45384-02	NUT TUERCA		1	

FIG. 30 LOWER CASING & DRIVE 4

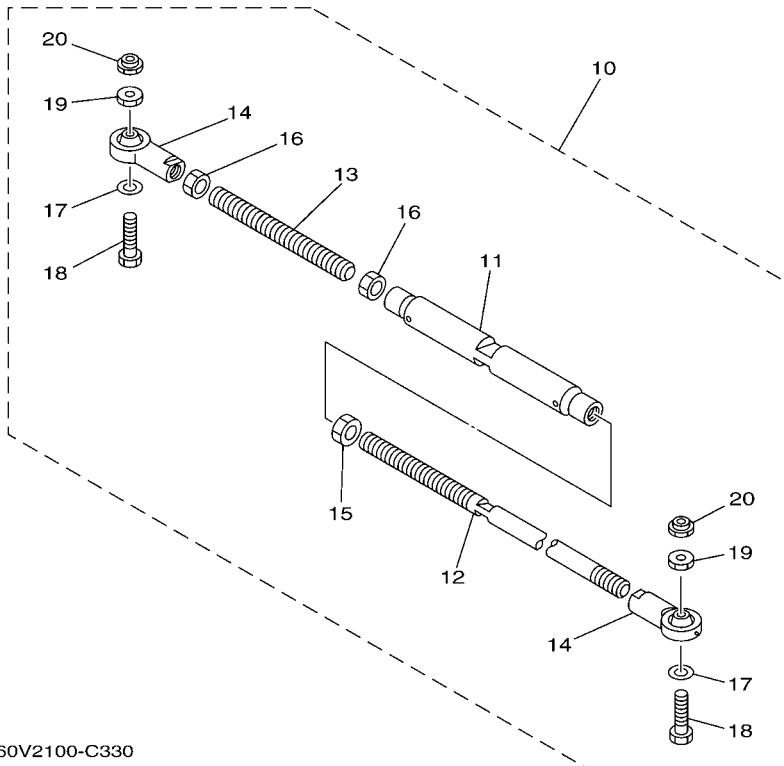
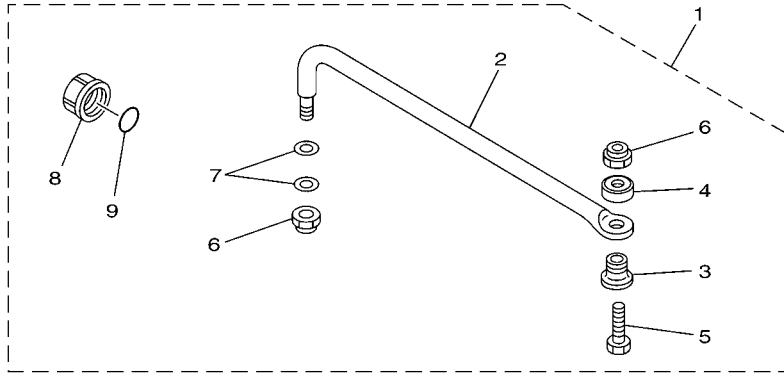
IMPULSOR E INFERIOR 4



FWD  
64P1010-C280

REF. NO.	PART NO. CODIGO Nº	DESCRIPTION DESCRIPCION	63P9	64P9	REMARKS OBSERVACIONES
1	63P-44361-00	TUBE, WATER 1 TUBO DE AGUA 1		1	
2	6E5-44365-00	DAMPER, WATER SEAL 1 HULE DE SELLO DE AGUA 1		1	
3	63P-44362-00	TUBE, WATER 2 TUBO DE AGUA 2		1	X(25.3") X(25.3")
4	6E5-44365-00	DAMPER, WATER SEAL 1 HULE DE SELLO DE AGUA 1		2	X(25.3") X(25.3")
5	6E5-44312-00	COVER, WATER PUMP HOUSING CUBIERTA CAJA BOMBA DE AGUA		2	X(25.3") X(25.3")
6	63P-44363-00	TUBE, WATER 3 TUBO DE AGUA 3		1	X(25.3") X(25.3")
7	93608-16M16	PIN, DOWEL PASADOR DE CLAVIJA		2	
8	97095-10045	BOLT PERNO		6	
9	92995-10100	WASHER ARANDELA		6	
10	92995-10600	WASHER ARANDELA		6	
11	90119-10008	BOLT, WITH WASHER TORNILLO CON ARANDELA		1	X(25.3") X(25.3")
12	6J9-45214-00	COVER, WATER INLET 1 CUBIERTA ENTRADA AGUA 1		1	
13	6J9-45215-00	COVER, WATER INLET 2 CUBIERTA ENTRADA AGUA 2		1	
14	90152-05M08	SCREW, COUNTERSUNK TORNILLO EMBUTIDO		1	
15	90185-05002	NUT, NYLON TUERCA AUTOBLOCANTE		1	
16	6K1-45371-02	TAB-TRIM QUILLA ESTABILIZADOR		1	
17	90105-10M00	BOLT, FLANGE TORNILLO		1	
18	63P-45987-00	SPACER 1 ESPACIADOR 1		1	
19	688-45997-01	SPACER 2 ESPACIADOR 2		1	
20	92990-18200	WASHER ARANDELA PLANA		1	
21	90171-18M04	NUT, CASTLE TUERCA ENTALLADA		1	
22	91490-40030	PIN, COTTER CHAVETA		1	
23	6K1-45970-01	PROPELLER (3X15-1/4"X15"-ML) PROPELA (3X15-1/4"X15"-ML)		1	UR UR
	6K1-45972-01	PROPELLER (3X13-3/4"X21"-ML) PROPELA (3X13-3/4"X21"-ML)		1	UR UR
	6K1-45974-02	PROPELLER (3X13-3/4"X19"-ML1) PROPELA (3X13-3/4"X19"-ML1)		1	UR UR
	6K1-45976-00	PROPELLER (3X13-3/8"X23"-ML) PROPELA (3X13-3/8"X23"-ML)		1	UR UR
	6K1-45978-02	PROPELLER (3X13-3/4"X17"-ML1) PROPELA (3X13-3/4"X17"-ML1)		1	UR UR





60V2100-C330

FIG. 31 STEERING GUIDE

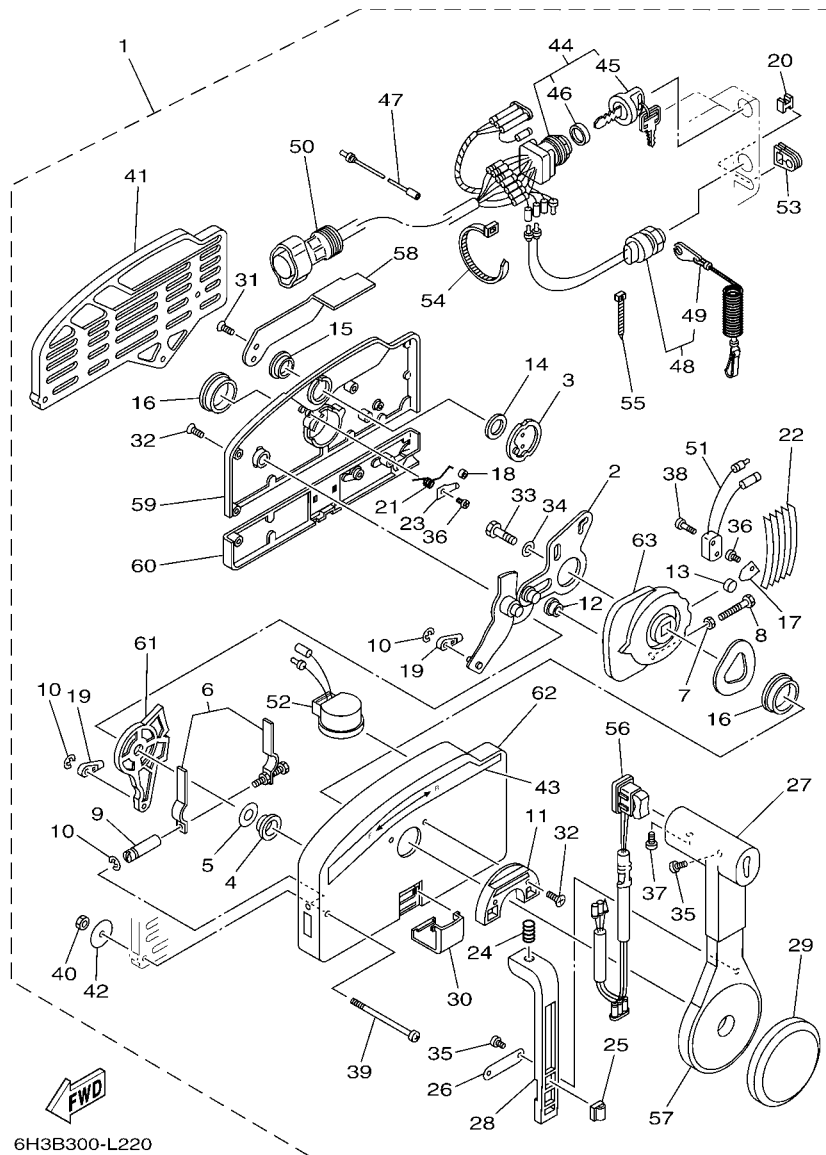
DIRECCIONGUIAR

REF. NO.	PART NO. CODIGO Nº	DESCRIPTION DESCRIPCION	63P9	64P9		REMARKS OBSERVACIONES
1	6E5-61350-02	STEERING GUIDE ATTACHMENT KIT ESTUCHE ADITAMENTO GUIA DE TIM	1			AP FOR BRA AP FOR BRA
2	6E5-61351-01	.ROD, STEERING LINK .VARILLA ESLABON DIRECCION	1			
3	90387-10M61	.COLLAR .ESPACIADOR	1			
4	90560-12M01	.SPACER .SEPARADOR	1			
5	6E5-61355-00	.BOLT .TORNILLO	1			
6	90185-09M01	.NUT, SELF-LOCKING .TUERCA AUTOBLOCANTE	2			
7	90201-10M20	.WASHER, PLATE .ARANDELA PLANA	2			
8	6E5-43145-01	.CAP, CLAMP BRACKET .TAPA	1			
9	93210-16275	.O-RING .ANILLO O	1			
10	6E5-61301-01	TWIN KIT (L:600-800MM) KIT ADITAMENTO (L:600-800MM)	1			AP AP
11	6E5-61313-00	.ADJUSTER .AJUSTADOR	1			
12	6E5-61311-11	.TIE BAR .BARRA SEPARADORA	1			
13	6E5-61315-00	.TIE BAR .ROTOR DE BOMBA AGUA	1			
14	6E5-61303-00	.STEERING AXLE COMP. .OJO-DIRECCION COMPL.	2			
15	90170-14M06	.NUT .TUERCA	1			
16	95380-14700	.NUT .TUERCA	2			
17	90201-10M76	.WASHER, PLATE .ARANDELA PLANA	2			
18	90101-09M70	.BOLT .TORNILLO	2			
19	90170-09M05	.NUT .TUERCA	2			
20	90185-09M01	.NUT, SELF-LOCKING .TUERCA AUTOBLOCANTE	2			



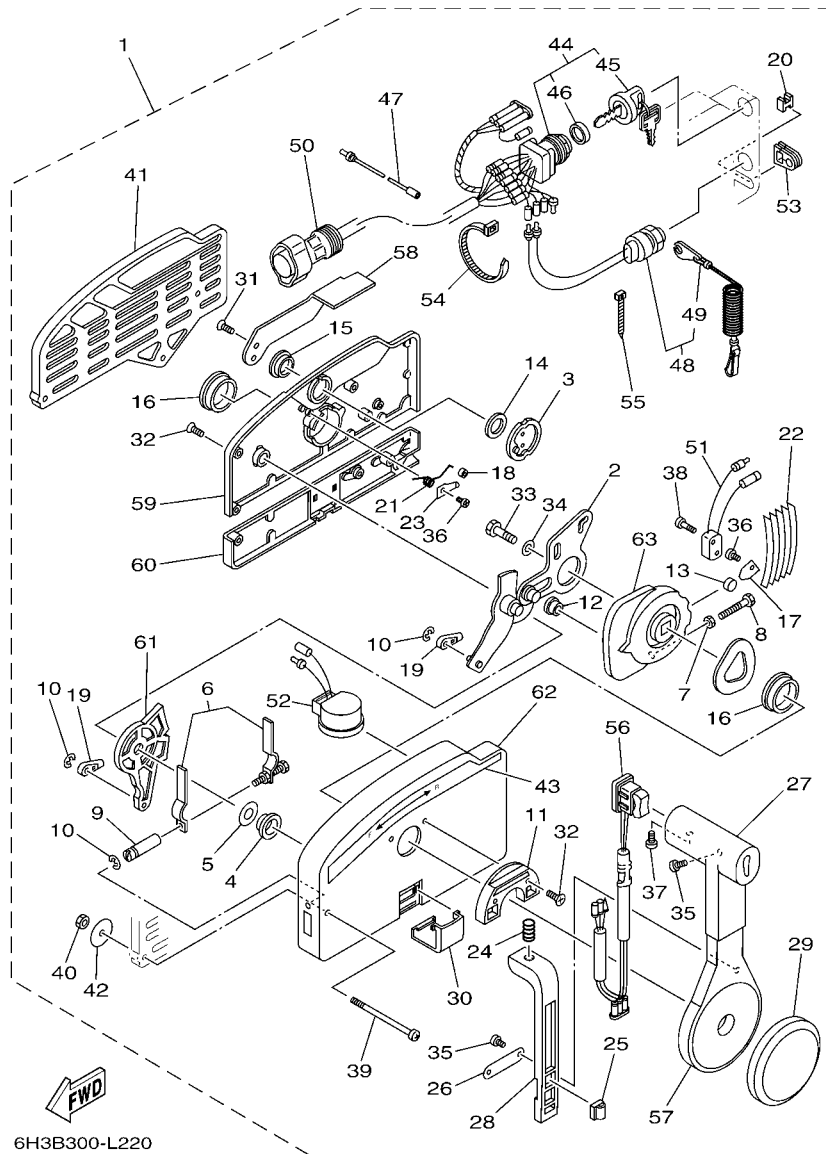


FIG. 33 REMOTE CONTROL ASSY 1 CONTROL REMOTO COMPL 1



6H3B300-L220

REF. NO.	PART NO. CODIGO Nº	DESCRIPTION DESCRIPCION	63P9	64P9	REMARKS OBSERVACIONES
1	703-48207-1A	REMOTE CONTROL ASSY (10P) REMOTO CONTROL COMPL. (10P)	1		AP BRA WITH PT/T SW. AP BRA WITH PT/T SW.
2	703-48261-01	.ARM, THROTTLE .BRAZO ACELERADOR	1		
3	703-48153-00	.SHAFT, FREE ACCEL. .EJE	1		
4	703-48235-00	.BUSHING .BUJE	1		
5	703-48268-00	.SPACER .ESPACIADOR 3	1		
6	703-48264-00	.FRICTION, THROTTLE .FRICCION DE ACELERADOR	1		
7	95380-05600	.NUT .TUERCA	1		
8	97380-05025	.BOLT .TORNILLO HEXAGONAL	1		
9	703-48265-00	.SHAFT, FRICTION .EJE FRICCION	1		
10	93430-06024	.CIRCLIP .SEGURO	3		
11	703-48245-00	.PLATE, LOCK .PLACA CERRADURA	1		
12	703-48252-00	.ROLLER, CAM .RODILLO LEVA	1		
13	701-48248-00	.ROLLER, FREE ACCEL. .RODILLO ACELERADOR LIBRE	1		
14	703-48198-00	.WASHER, WAVE .RONDANA ONDULADA 3	1		
15	703-48243-00	.BUSHING .BUJE 3	1		
16	703-48236-00	.BUSHING 1 .BUJE	2		
17	703-48189-00	.RETAINER .RETENEDOR	1		
18	703-48234-00	.ROLLER, DETENT .RODILLO	1		
19	703-48345-01	.CABLE END, REMOTE CONTROL 2 .TERMINAL CABLE DE CONTROL REMO	2		
20	703-48358-00	.ANCHOR, CABLE .ABRAZADERA CABLE	1		
21	703-48244-00	.SPRING, FREE ACCEL. .RESORTE ACELERADOR LIBRE	1		
22	703-48238-00	.SPRING, DETENT .RESORTE	5		
23	703-48246-00	.SPACER .ESPACIADOR	1		
24	703-48227-00	.SPRING, NEUTRAL LOCK .RESORTE DE SEGURO	1		
25	703-82594-00	.CLAMP .GRAMPA	1		WITH PT/T SW. WITH PT/T SW.
26	703-48226-00	.PLATE, STOPPER .PLACA RETEN	1		
27	703-48222-00	.GRIP, CONTROL LEVER .MANGO DE PALANCA CONTROL	1		SINGLE SINGLE



6H3B300-L220

FIG. 33 REMOTE CONTROL ASSY 1 CONTROL REMOTO COMPL 1

REF. NO.	PART NO. CODIGO Nº	DESCRIPTION DESCRIPCION	63P9	64P9	REMARKS OBSERVACIONES
28	703-48223-00	.LOCK, NEUTRAL .CERRADURA NEUTRO	1		
29	703-48225-00	.COVER .CUBIERTA	1		
30	703-48219-00	.COVER, LEAD .CUBIERTA	1		
31	703-48281-00	.SCREW .TORNILLO 1	2		
32	703-48282-00	.SCREW .TORNILLO 2	7		
33	97380-08030	.BOLT .TORNILLO HEXAGONAL	1		
34	92990-08600	.WASHER, PLATE .ARANDELA PLANA	1		
35	98580-04010	.SCREW, PAN HEAD .TORNILLO DE CABEZA CRUZADA	3		
36	98580-04006	.SCREW, PAN HEAD .TORNILLO DE CABEZA CRUZADA	2		
37	98580-05010	.SCREW, PAN HEAD .TORNILLO DE CABEZA CRUZADA	1		
38	98580-03015	.SCREW, PAN HEAD .TORNILLO DE CABEZA CRUZADA	2		
39	703-48291-10	.SCREW (M6) .TORNILLO (M6)	3		
40	95380-06600	.NUT, HEXAGON .TUERCA	3		
41	703-48293-10	.SPACER, REMOTE CONTROL .ESPACIADOR	1		SINGLE SINGLE
42	701-48287-00	.WASHER .ARANDELA	3		
43	703-48215-00	.GRAPHIC .CALCOMANIA 1	1		
44	703-82510-43	.MAIN SWITCH ASSY .CONJUNTO DE LLAVE IGNICION	1		
45	703-82577-00	.CAP, KEY .TAPA	1		
46	6K1-82532-00	.CAP .TAPA	1		
47	703-82531-00	.WIRE, LEAD (L70) .CABLE CONDUCTOR (L70)	1		
48	688-82575-01	.ENGINE STOP SWITCH ASSY .INTERRUPTOR DE PARADA COMPL	1		
49	682-82556-00	.LANYARD, STOP SWITCH .CORDON DE INTERRUPTOR PARADA	1		
50	688-8258A-20	.EXTENSION, WIRE HARNESS (4.9M) .EXTENSION, ARNES DE CABLES (4)	1		(10P) (10P)
51	703-82540-00	.NEUTRAL SWITCH ASSY .INTERRUPTOR NEUTRAL COMPL	1		
52	703-83383-11	.BUZZER .ZUMBADOR	1		
53	703-48284-10	.GROMMET .TAPON	1		
54	703-82591-00	.BAND .BANDA	3		

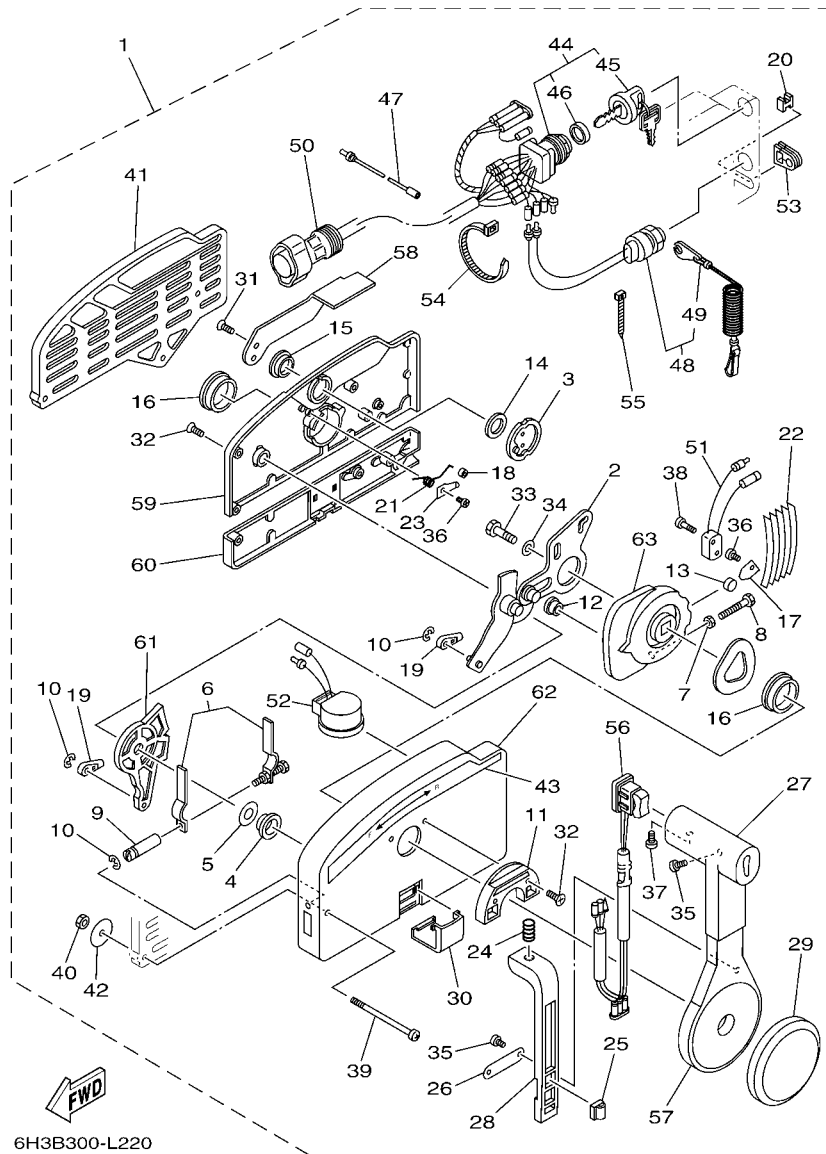
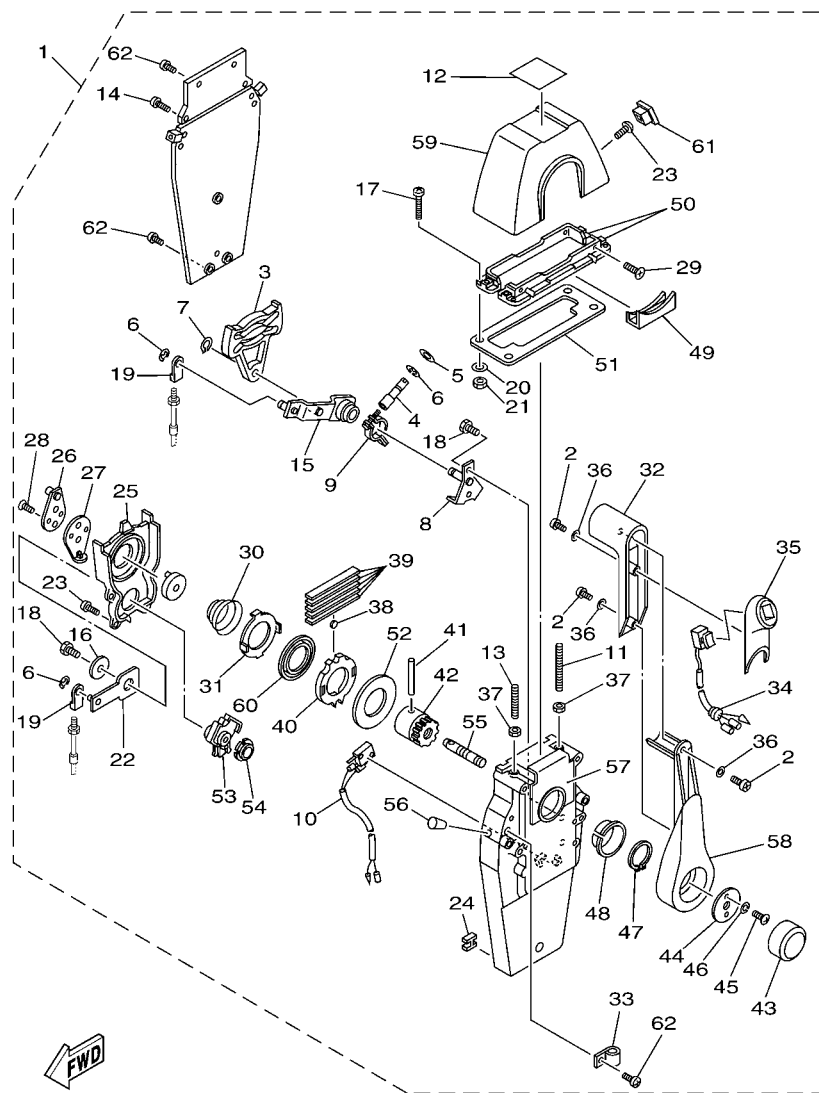


FIG. 33 REMOTE CONTROL ASSY 1 CONTROL REMOTO COMPL 1

REF. NO.	PART NO. CODIGO Nº	DESCRIPTION DESCRIPCION	63P9	64P9	REMARKS OBSERVACIONES
55	703-82592-00	.BAND .BANDA	1		
56	703-82563-12	.TRIM & TILT SWITCH ASSY .INTERRUPTOR DE INCLINACION	1		WITH PT/T SW. WITH PT/T SW.
57	703-48221-00	.LEVER, CONTROL .PALANCA CONTROL	1		
58	703-48152-00	.KNOB, FREE ACCEL. .PERILLA	1		
59	703-48212-00	.BACK PLATE 1 .PLACA TRASERA 1	1		
60	703-48213-00	.BACK PLATE 2 .PLACA TRASERA 2	1		
61	703-48271-00	.ARM, SHIFT .BRAZO CAMBIADOR	1		
62	703-48211-02	.HOUSING,1 .CAJA	1		
63	703-48232-00	.GEAR .ENGRANAJE 1	1		

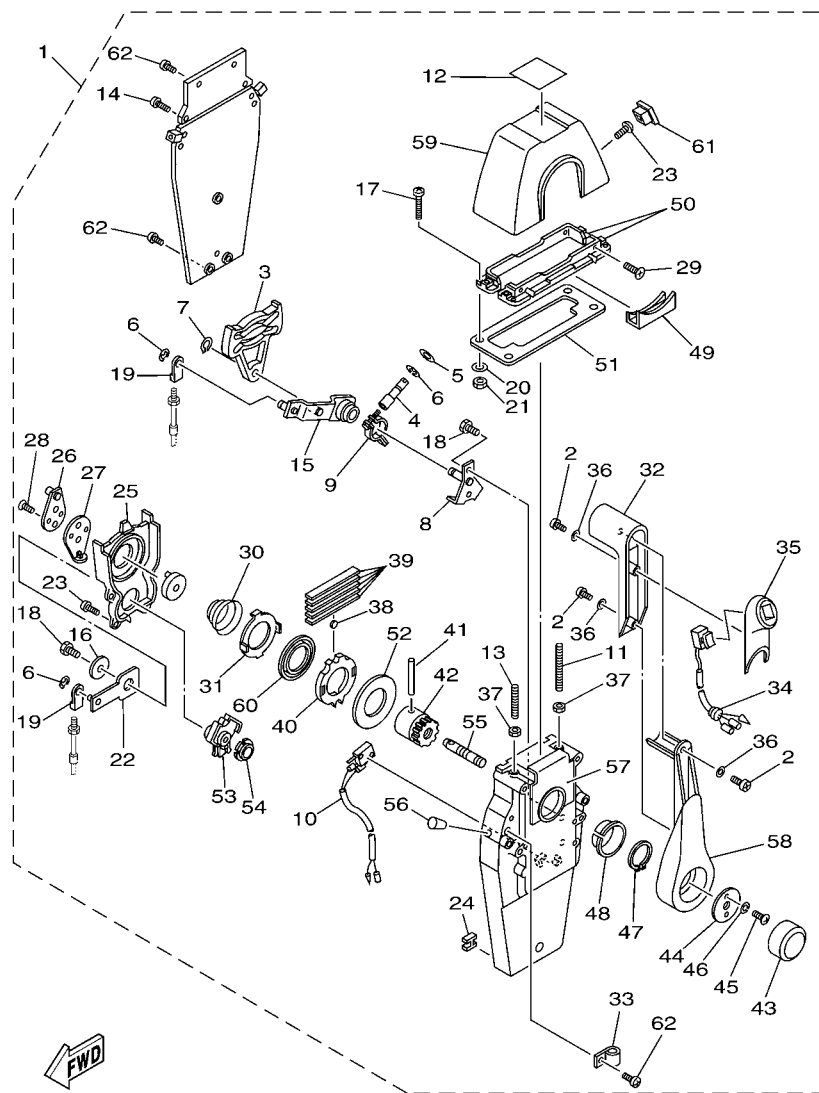
FIG. 34 REMOTE CONTROL ASSY 2 CONTROL REMOTO COMPL 2



6C23100-F340

REF. NO.	PART NO. CODIGO Nº	DESCRIPTION DESCRIPCION	63P9	64P9		REMARKS OBSERVACIONES
1	704-48205-P1	REMOTE CONTROL ASSY (RIGHT) REMOTO CONTROL COMPL (RECTO)	1			AP CAR WITH PT/T SW. AP CAR WITH PT/T SW.
2	704-48128-00	.SCREW 2 .TORNILLO 2	3			
3	EL8-48251-00	.PLATE, CAM .PLACA, LEVA	1			
4	704-48265-00	.SHAFT, FRICTION .EJE FRICCION	1			
5	701-48246-00	.SPACER .ESPACIADOR	1			
6	93430-06024	.CIRCLIP .SEGURO	4			
7	EL8-48259-00	.CIRCLIP 1 .SEGURO	1			
8	704-48262-00	.SHAFT, THROTTLE .EJE DE ACELERADOR	1			
9	704-48264-00	.THROTTLE, FRICTION .FRICCION DE ACELERADOR	1			
10	704-82540-20	.NEUTRAL SWITCH ASSY .INTERRUPTOR NEUTRAL COMPL	1			
11	EL8-48281-00	.SCREW .TORNILLO 1	1			
12	704-48215-20	.GRAPHIC .CALCOMANIA 1	1			
13	704-48281-00	.SCREW .TORNILLO 1	1			
14	97890-05025	.SCREW, PAN HEAD .TORNILLO	2			
15	704-48261-00	.ARM, THROTTLE .BRAZO ACELERADOR	1			
16	EL8-48191-00	.WASHER 1 .ARANDELA	1			
17	704-48283-00	.SCREW .TORNILLO 3	4			
18	97380-06018	.BOLT .TORNILLO HEXAGONAL	3			
19	703-48345-01	.CABLE END, REMOTE CONTROL 2 .TERMINAL CABLE DE CONTROL REMO	2			
20	704-48287-00	.WASHER .ARANDELA	4			
21	95380-05600	.NUT .TUERCA	4			
22	704-48271-00	.ARM, SHIFT .BRAZO CAMBIADOR	1			
23	EL8-48127-00	.SCREW 1 .TORNILLO 1	10			
24	703-48358-00	.ANCHOR, CABLE .ABRAZADERA CABLE	1			
25	704-48231-00	.HOUSING, GEAR .CAJA, ENGRANAJE	1			
26	EL8-48241-00	.ARM, DRIVE .BRAZO, MANDO	1			
27	EL8-48254-00	.STOPPER, THROTTLE ADJUSTING .TAPON	1			

FIG. 34 REMOTE CONTROL ASSY 2 CONTROL REMOTO COMPL 2

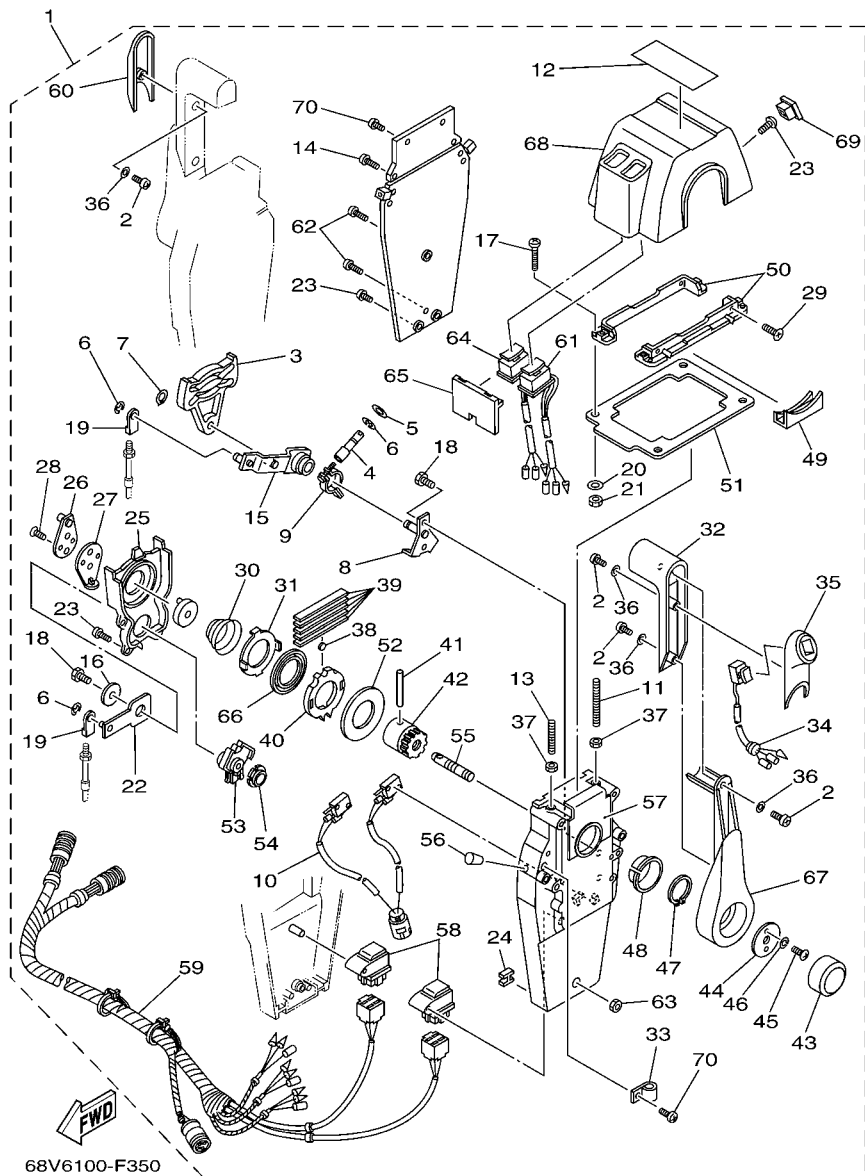


6C23100-F340

REF. NO.	PART NO. CODIGO Nº	DESCRIPTION DESCRIPCION	63P9	64P9	REMARKS OBSERVACIONES
28	92780-06020	.SCREW, FLAT HEAD .TORNILLO CABEZA PLANA	2		
29	98780-05018	.SCREW, FLAT HEAD .TORNILLO CABEZA PLANA	4		
30	EL8-48244-00	.SPRING, FREE ACCEL. .RESORTE ACELERADOR LIBRE	1		
31	EL8-48245-00	.PLATE, LOCK .PLACA CERRADURA	1		
32	704-48222-P0	.GRIP, CONTROL LEVER .MANGO DE PALANCA CONTROL	1		
33	704-82594-00	.CLAMP .GRAMPA	1		
34	704-82563-41	.TRIM & TILT SWITCH ASSY .INTERRUPTOR DE INCLINACION	1		
35	704-48229-P1	.GRIP, CONTROL LEVER .MANGO DE PALANCA CONTROL 2	1		
36	92990-05300	.WASHER, INTERNAL TOOTH .ARANDELA PLANA	3		
37	95380-06600	.NUT, HEXAGON .TUERCA	2		
38	701-48248-00	.ROLLER, FREE ACCEL. .RODILLO ACELERADOR LIBRE	1		
39	704-48238-00	.SPRING, DETENT .RESORTE	5		
40	704-48232-P1	.GEAR .ENGRANAJE 1	1		
41	EL8-48164-00	.PIN 2 .PASADOR 2	1		
42	704-48242-10	.SHAFT, DRIVE .EJE, PROPULSION	1		
43	6X3-48225-20	.COVER .CUBIERTA	1		
44	704-48192-00	.WASHER 2 .RONDANA 2	1		
45	97890-06018	.SCREW, PAN HEAD .TORNILLO	2		
46	92990-06300	.WASHER, INTERNAL TOOTH .ARANDELA PLANA	2		
47	EL8-48279-00	.CIRCLIP 2 .SEGURO2	1		
48	704-48234-00	.BUSHING 1 .BUJE	1		
49	704-48219-P0	.COVER, LEAD .CUBIERTA	1		
50	704-48144-10	.PLATE, STOPPER 2 .PLACA, RETEN 2	2		
51	704-48176-00	.GROMMET .TOPON	1		
52	704-48192-P0	.WASHER 2 .RONDANA 2	1		
53	704-48233-00	.GEAR 2 .ENGRANAJE 2	1		
54	704-48235-00	.BUSHING .BUJE	1		



FIG. 35 REMOTE CONTROL ASSY 3 CONTROL REMOTO COMPL 3



REF. NO.	PART NO. CODIGO Nº	DESCRIPTION DESCRIPCION	63P9	64P9	REMARKS OBSERVACIONES
1	704-48207-P1	REMOTE CONTROL ASSY REMOTO CONTROL COMPL.		1	AP WITH PT/T SW. AP WITH PT/T SW.
2	704-48128-00	.SCREW 2 .TORNILLO 2		6	
3	EL8-48251-00	.PLATE, CAM .PLACA,LEVA		2	
4	704-48265-00	.SHAFT, FRICTION .EJE FRICCION		2	
5	701-48246-00	.SPACER .ESPACIADOR		2	
6	93430-06024	.CIRCLIP .SEGURO		8	
7	EL8-48259-00	.CIRCLIP 1 .SEGURO		2	
8	704-48262-00	.SHAFT, THROTTLE .EJE DE ACELERADOR		2	
9	704-48264-00	.THROTTLE, FRICTION .FRICCION DE ACELERADOR		2	
10	704-82540-30	.NEUTRAL SWITCH ASSY .INTERRUPTOR NEUTRAL COMPL		1	
11	EL8-48281-00	.SCREW .TORNILLO 1		2	
12	704-48215-30	.GRAPHIC .CALCOMANIA 1		1	
13	704-48281-00	.SCREW .TORNILLO 1		2	
14	97890-05025	.SCREW, PAN HEAD .TORNILLO		4	
15	704-48261-00	.ARM, THROTTLE .BRAZO ACELERADOR		2	
16	EL8-48191-00	.WASHER 1 .ARANDELA		2	
17	704-48283-00	.SCREW .TORNILLO 3		4	
18	97380-06018	.BOLT .TORNILLO HEXAGONAL		6	
19	703-48345-01	.CABLE END, REMOTE CONTROL 2 .TERMINAL CABLE DE CONTROL REMO		4	
20	704-48287-00	.WASHER .ARANDELA		4	
21	95380-05600	.NUT .TUERCA		4	
22	704-48271-00	.ARM, SHIFT .BRAZO CAMBIADOR		2	
23	EL8-48127-00	.SCREW 1 .TORNILLO 1		18	
24	703-48358-00	.ANCHOR, CABLE .ABRAZADERA CABLE		2	
25	704-48231-00	.HOUSING, GEAR .CAJA,ENGRANAJE		2	
26	EL8-48241-00	.ARM, DRIVE .BRAZO,MANDO		2	
27	EL8-48254-00	.STOPPER, THROTTLE ADJUSTING .TAPON		2	



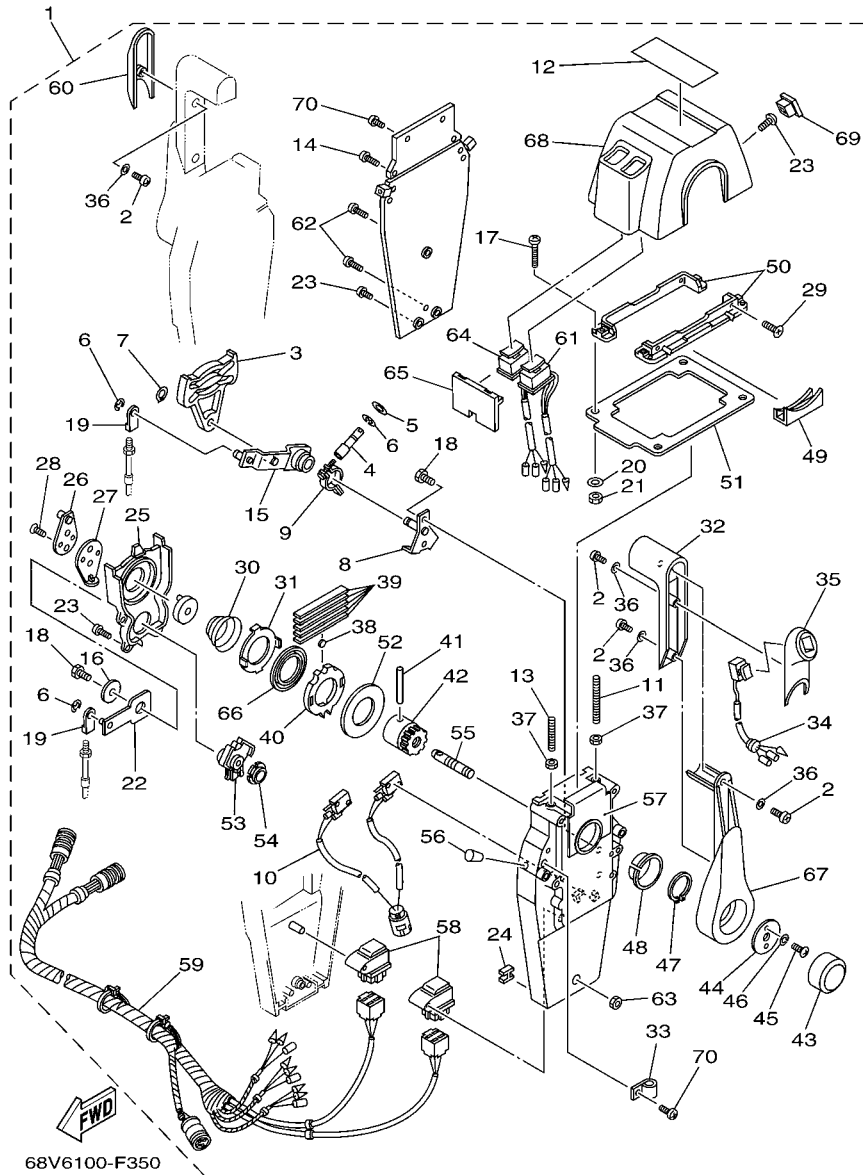


FIG. 35 REMOTE CONTROL ASSY 3 CONTROL REMOTO COMPL 3

REF. NO.	PART NO. CODIGO Nº	DESCRIPTION DESCRIPCION	63P9	64P9	REMARKS OBSERVACIONES
28	92780-06020	.SCREW, FLAT HEAD .TORNILLO CABEZA PLANA		4	
29	98780-05018	.SCREW, FLAT HEAD .TORNILLO CABEZA PLANA		4	
30	EL8-48244-00	.SPRING, FREE ACCEL. .RESORTE ACELERADOR LIBRE		2	
31	EL8-48245-00	.PLATE, LOCK .PLACA CERRADURA		2	
32	704-48222-P0	.GRIP, CONTROL LEVER .MANGO DE PALANCA CONTROL		2	
33	704-82594-00	.CLAMP .GRAMPA		1	
34	704-82563-51	.TRIM & TILT SWITCH ASSY .INTERRUPTOR DE INCLINACION		1	
35	704-48229-P1	.GRIP, CONTROL LEVER .MANGO DE PALANCA CONTROL 2		1	
36	92990-05300	.WASHER, INTERNAL TOOTH .ARANDELA PLANA		6	
37	95380-06600	.NUT, HEXAGON .TUERCA		4	
38	701-48248-00	.ROLLER, FREE ACCEL. .RODILLO ACELERADOR LIBRE		2	
39	704-48238-00	.SPRING, DETENT .RESORTE		10	
40	704-48232-P1	.GEAR .ENGRANAJE 1		2	
41	EL8-48164-00	.PIN 2 .PASADOR 2		2	
42	704-48242-10	.SHAFT, DRIVE .EJE, PROPULSION		2	
43	6X3-48225-20	.COVER .CUBIERTA		2	
44	704-48192-00	.WASHER 2 .RONDANA 2		2	
45	97890-06018	.SCREW, PAN HEAD .TORNILLO		4	
46	92990-06300	.WASHER, INTERNAL TOOTH .ARANDELA PLANA		4	
47	EL8-48279-00	.CIRCLIP 2 .SEGURO2		2	
48	704-48234-00	.BUSHING 1 .BUJE		2	
49	704-48219-P0	.COVER, LEAD .CUBIERTA		2	
50	704-48144-20	.PLATE, STOPPER 2 .PLACA, RETEN 2		2	
51	704-48176-10	.GROMMET .TOPON		1	
52	704-48192-P0	.WASHER 2 .RONDANA 2		2	
53	704-48233-00	.GEAR 2 .ENGRANAJE 2		2	
54	704-48235-00	.BUSHING .BUJE		2	

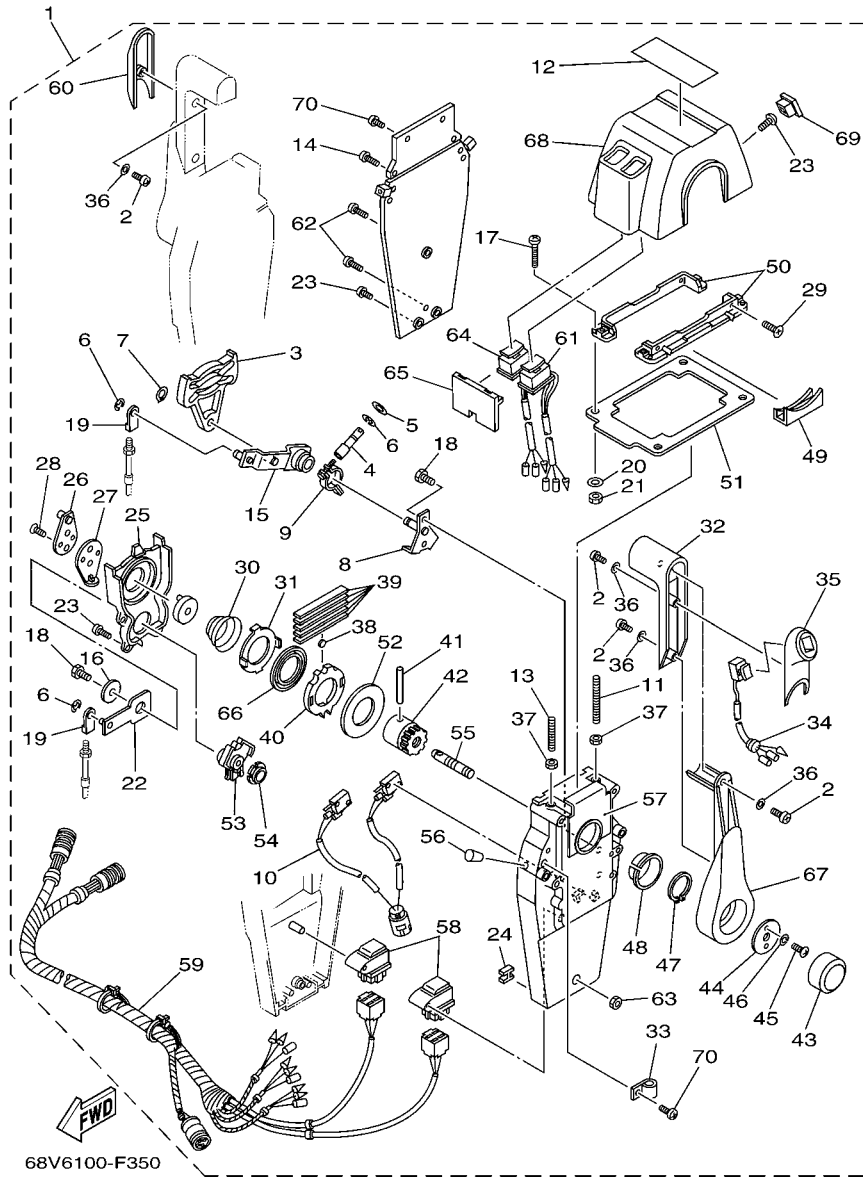
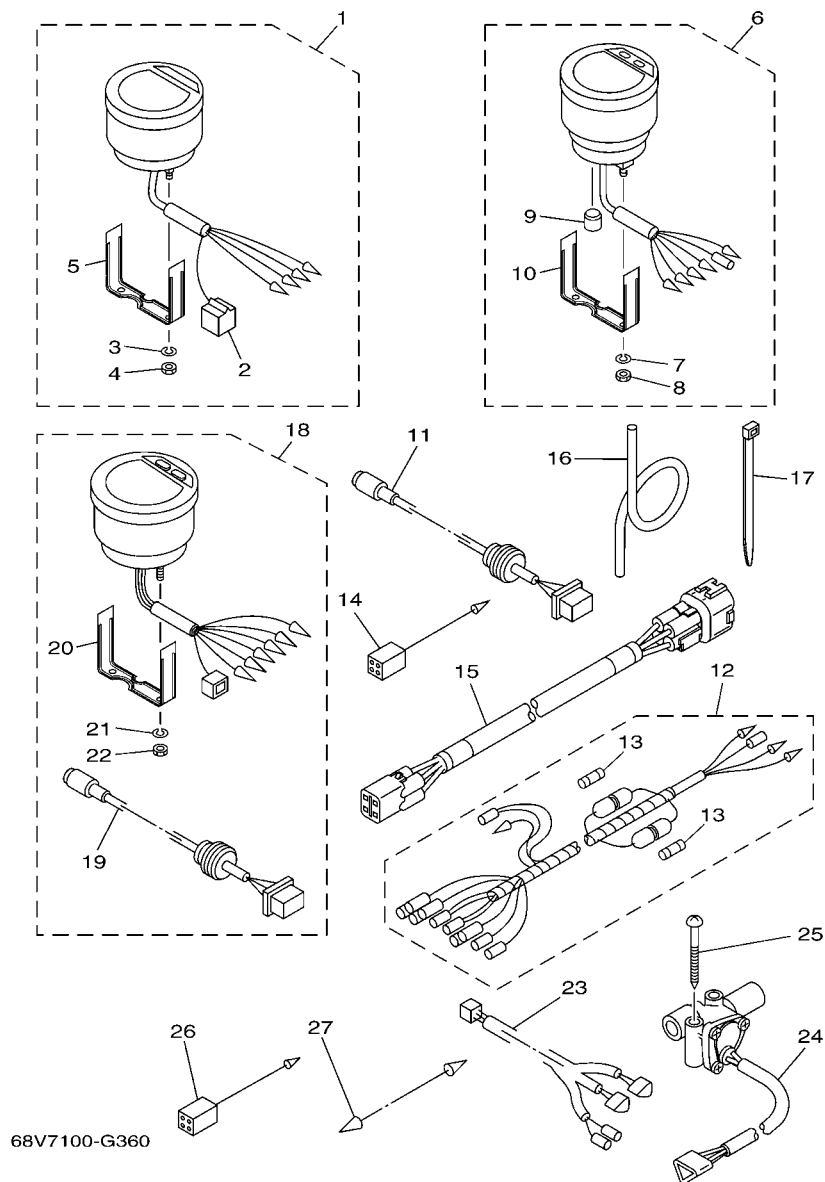


FIG. 35 REMOTE CONTROL ASSY 3 CONTROL REMOTO COMPL 3

REF. NO.	PART NO. CODIGO Nº	DESCRIPTION DESCRIPCION	63P9	64P9	REMARKS OBSERVACIONES
55	704-48153-00	.SHAFT, FREE ACCEL. .EJE		2	
56	704-48166-00	.PLUG .TAPON		2	
57	704-48284-P0	.GROMMET .TAPON		2	
58	704-81950-10	.RELAY ASSY .RELE COMPLETO		2	
59	704-82590-10	.WIRE HARNESS ASSY .CONJUNTO DE CABLES		1	
60	704-48229-R0	.GRIP, CONTROL LEVER .MANGO DE PALANCA CONTROL 2		1	
61	704-82563-H1	.TRIM & TILT SWITCH ASSY .INTERRUPTOR DE INCLINACION		1	
62	704-48128-00	.SCREW 2 .TORNILLO 2		3	
63	704-48156-00	.NUT 1 .TUERCA 1		1	
64	704-82563-J1	.TRIM & TILT SWITCH ASSY .INTERRUPTOR DE INCLINACION		1	
65	704-48285-10	.GROMMET 2 .TAPON 2		1	
66	704-48178-00	.PLATE, SHIFT .PLACA		2	
67	704-48221-P0	.LEVER, CONTROL .PALANCA CONTROL		2	
68	704-48119-41	.COVER .CUBIERTA		1	
69	704-48167-11	.PLUG .TAPON AGUJERO		1	
70	97890-05016	.SCREW, PAN HEAD .TORNILLO		5	

FIG. 36 METER

MEDIDOR

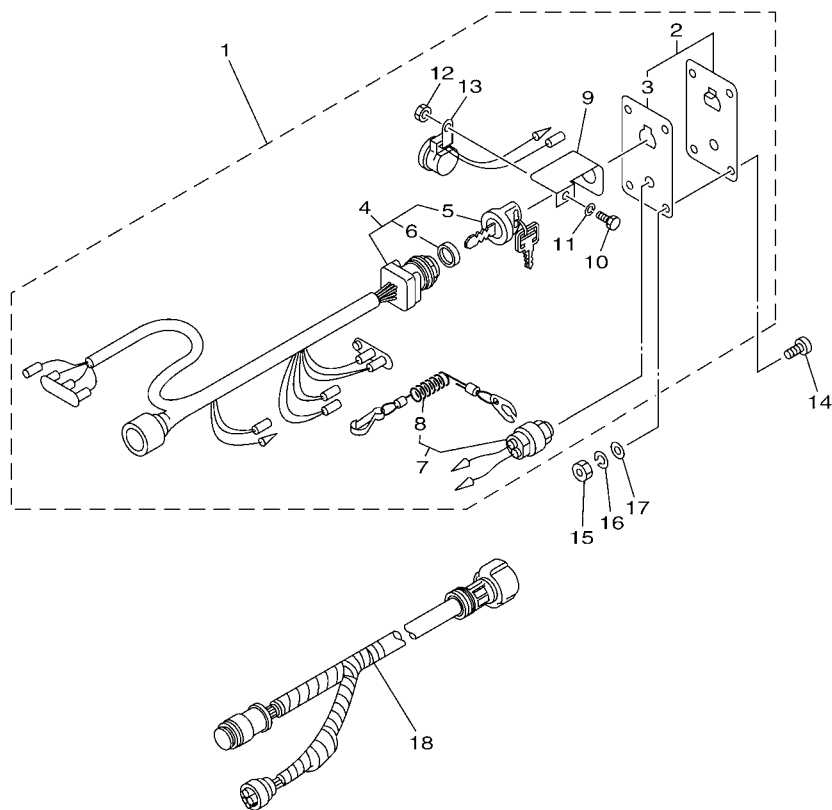


REF. NO.	PART NO. CODIGO Nº	DESCRIPTION DESCRIPCION	63P9	64P9	REMARKS OBSERVACIONES
1	6Y5-8350T-90	DIGITAL TACHOMETER ASSY TACOMETRO DIGITAL COMPLETO	1	1	AP FOR BRA AP FOR BRA
2	9E450-04533	.CONNECTOR .CONECTOR	1	1	F-4-W F-4-W
3	92990-04100	.WASHER, SPRING .ARANDELA PLANA	2	2	
4	95380-04600	.NUT .TUERCA	2	2	
5	6Y5-8355X-T1	.BRACKET, METER 1 .SOSTEN	1	1	
6	6Y5-83570-S5	SPEEDOMETER ASSY VELOCIMETRO COMPLETO	1		AP FOR BRA AP FOR BRA
7	92990-04100	.WASHER, SPRING .ARANDELA PLANA	2		
8	95380-04600	.NUT .TUERCA	2		
9	6Y5-83533-T2	.GROMMET .ANILLO PROTECTOR	1		
10	6Y5-8355X-T1	.BRACKET, METER 1 .SOSTEN	1		
11	6Y5-87122-S0	CORD ASSY 1 CABLE COMPLETA 1	1		AP FOR BRA AP FOR BRA
12	6Y5-83553-M0	WIRE, LEAD (L=2.5M) CABLE CONDUCTOR (L=2.5M)	1		AP FOR BRA AP FOR BRA
	6Y5-83553-00	WIRE, LEAD (L=2.5M) CABLE CONDUCTOR (L=2.5M)		1	AP FOR BRA AP FOR BRA
13	1E6-82151-00	.FUSE (10A) .FUSIBLE (10A)	2		FOR 6Y5-83553-M0 FOR 6Y5-83553-M0
	1E6-82151-00	.FUSE (10A) .FUSIBLE (10A)		1	FOR 6Y5-83553-00 FOR 6Y5-83553-00
14	6Y5-82117-00	WIRE, LEAD (BLACK) (L300) CABLE, CONDUCTOR (NEGRO)	1		AP FOR BRA AP FOR BRA
15	6Y5-83653-30	WIRE, LEAD (L=8.0M) CABLE CONDUCTOR (L=8.0M)	1		AP FOR BRA 4P,8M AP FOR BRA 4P,8M
	6Y5-83653-40	WIRE, LEAD (L=9.0M) CABLE CONDUCTOR (L=9.0M)		1	AP FOR BRA 4P,9M AP FOR BRA 4P,9M
16	6Y5-83557-10	TUBE (8M) TUBO (8M)	1		AP FOR BRA AP FOR BRA
17	90465-11M10	CLAMP BRIDA	2		AP FOR BRA AP FOR BRA
18	6Y5-8350F-00	FUEL MANAGEMENT METER MEDIDOR DE GESTION COMBUSTIBLE	1		AP FOR BRA AP FOR BRA
19	6Y5-87122-S0	.CORD ASSY 1 .CABLE COMPLETA 1	1		
20	6Y5-8355X-T1	.BRACKET, METER 1 .SOSTEN	1		
21	92990-04100	.WASHER, SPRING .ARANDELA PLANA	2		
22	95380-04600	.NUT .TUERCA	2		
23	6Y5-83553-F1	WIRE, LEAD (L=8.0M) CABLE CONDUCTOR (L=8.0M)	1		AP FOR BRA AP FOR BRA
24	6Y5-85752-02	SENDER UNIT ASSY, FUEL METER UNIDAD TRANSM. MED. COMBUST.		2	AP FOR BRA AP FOR BRA



FIG. 37 SWITCH & PANEL 1

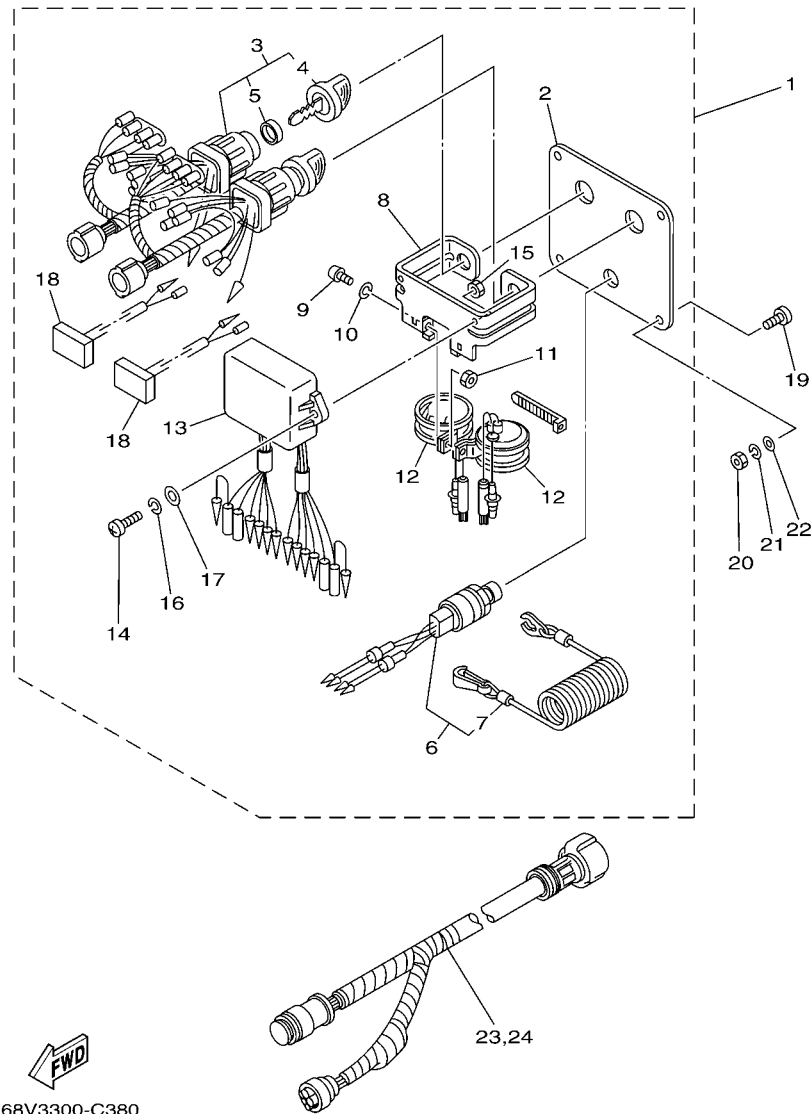
PANEL DE INTERRUPTOR 1



REF. NO.	PART NO. CODIGO Nº	DESCRIPTION DESCRIPCION	63P9	64P9		REMARKS OBSERVACIONES
1	6R5-82570-05	PANEL SWITCH ASSY INTERRUPTOR DE PANEL COMPL.	1			AP FOR CAR AP FOR CAR
2	704-82571-02	.PANEL, SWITCH .PANEL DE INTERRUPTOR	1			
3	6R5-82588-01	..PLATE ..PLACA	1			
4	6R5-82510-02	.MAIN SWITCH ASSY .CONJUNTO DE LLAVE IGNICION	1			
5	676-82577-00	..CAP, KEY ..TAPA	1			
6	703-82532-00	..CAP ..TAPA	1			
7	688-82575-01	.ENGINE STOP SWITCH ASSY .INTERRUPTOR DE PARADA COMPL	1			
8	682-82556-00	..LANYARD, STOP SWITCH ..CORDON DE INTERRUPTOR PARADA	1			
9	64D-82581-00	.STAY, CORD CLAMP .SOPORTE DE GRAMPA DE CABLE	1			
10	97303-05012	.BOLT .TORNILLO	1			
11	92903-05100	.WASHER, SPRING .RONDANA SENCILLA	1			
12	95303-05700	.NUT .TUERCA	1			
13	6R5-83383-00	.BUZZER .ZUMBADOR	1			
14	90149-05M05	SCREW TORNILLO DE REGLAJE	4			AP FOR CAR AP FOR CAR
15	95303-05600	NUT TUERCA	4			AP FOR CAR AP FOR CAR AP FOR CAR
16	92903-05100	WASHER, SPRING RONDANA SENCILLA	4			AP FOR CAR AP FOR CAR AP FOR CAR
17	92903-05600	WASHER, PLATE RONDANA SENCILLA	4			AP FOR CAR AP FOR CAR AP FOR CAR
18	6K1-8258A-40	EXTENSION, WIRE HARNESS (8M) EXTENSION, ARNES DE CABLES (8M)	1			AP FOR CAR (10P) AP FOR CAR (10P)



6BM4200-L370

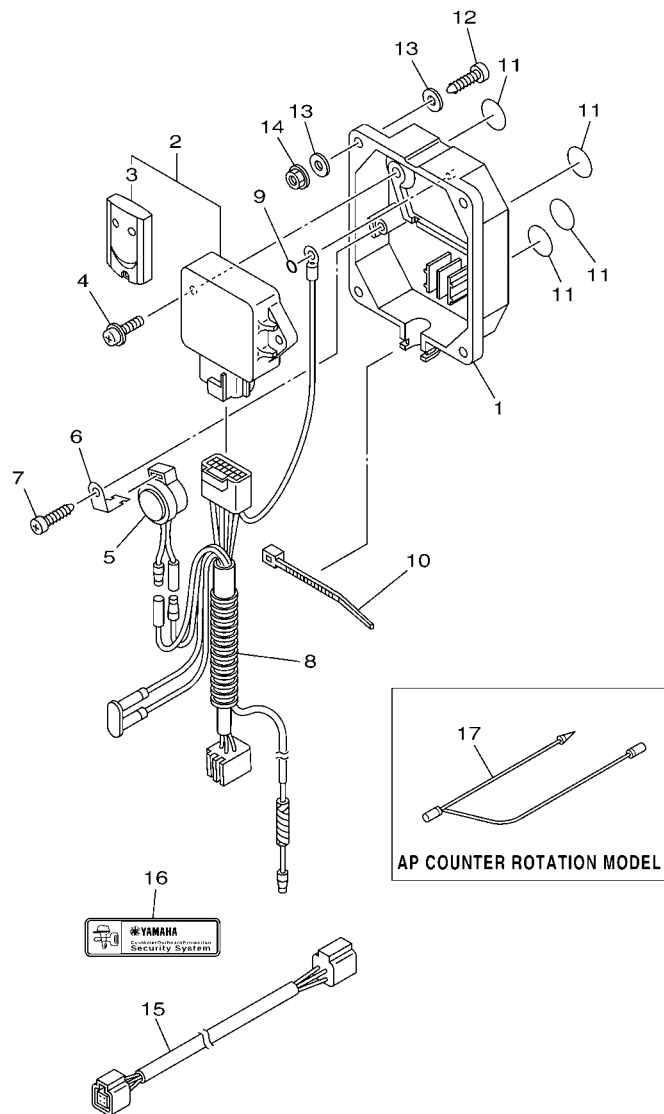


68V3300-C380

FIG. 38 SWITCH & PANEL 2

PANEL DE INTERRUPTOR 2

REF. NO.	PART NO. CODIGO Nº	DESCRIPTION DESCRIPCION	63P9	64P9	REMARKS OBSERVACIONES
1	6K1-82570-08	PANEL SWITCH ASSY INTERRUPTOR DE PANEL COMPL.		1	AP FOR BRA AP FOR BRA
2	6K1-82571-02	.PLATE, PANEL SWITCH .PANEL DE INTERRUPTOR		1	
3	6K1-82510-06	.MAIN SWITCH ASSY .CONJUNTO DE LLAVE IGNICION		2	
4	703-82577-00	..CAP, KEY ..TAPA		1	
5	6K1-82532-00	..CAP ..TAPA		1	
6	6K1-82575-00	.ENGINE STOP SWITCH ASSY .INTERRUPTOR DE PARADA COMPL		1	
7	682-82556-00	..LANYARD, STOP SWITCH ..CORDON DE INTERRUPTOR PARADA		1	
8	6K1-83614-01	.BRACKET .SOPORTE		1	
9	98980-05010	.SCREW, BIND .TORNILLO DE LIGAR		2	
10	92990-05100	.WASHER, SPRING .ARANDELA PLANA		2	
11	95380-05600	.NUT .TUERCA		2	
12	688-83383-11	.BUZZER .ZUMBADOR		2	
13	6K1-85830-01	.CONTROL UNIT ASSY .UNIDAD CONTROL		1	
14	98980-06020	.SCREW, BIND .TORNILLO DE LIGAR		2	
15	95380-06600	.NUT, HEXAGON .TUERCA		2	
16	92990-06100	.WASHER, SPRING .ARANDELA PLANA		2	
17	92990-06600	.WASHER, PLATE .ARANDELA PLANA		2	
18	6K1-81980-00	.DIODE ASSY .CONJUNTO DIODO		2	
19	90149-05M05	SCREW TORNILLO DE REGLAJE		4	AP FOR BRA AP FOR BRA
20	95380-05600	NUT TUERCA		4	AP FOR BRA AP FOR BRA
21	92990-05100	WASHER, SPRING ARANDELA PLANA		4	AP FOR BRA AP FOR BRA
22	92990-05600	WASHER, PLATE ARANDELA PLANA		4	AP FOR BRA AP FOR BRA
23	6K1-8258A-40	EXTENSION, WIRE HARNESS (8M) EXTENSION, ARNES DE CABLES (8M)		1	AP FOR BRA (10P) AP FOR BRA (10P)
24	61B-8258A-01	EXTENSION, WIRE HARNESS (9.5M) EXTENSION, ARNES DE CABLES(9.5		1	AP FOR BRA (10P) AP FOR BRA (10P)



63P9100-L320

FIG. 39 OPTIONAL PARTS

PARTES OPCIONALES

REF. NO.	PART NO. CODIGO Nº	DESCRIPTION DESCRIPCION	63P9	64P9	REMARKS OBSERVACIONES
1	6Y8-86267-00	CASE COMPLETE 1 CAJA COMPLETA 1	1		FOR CAR ONLY FOR CAR ONLY
2	6Y8-86260-11	REMOTE CONTROL UNIT ASSY UNIDAD DE CONTROL REMOTO COMPL	1		FOR CAR ONLY FOR CAR ONLY
3	6AA-86261-21	.TRANSMITTER COMP .TRANSMISOR	2		
4	97980-06216	SCREW, WITH WASHER TORNILLO, CON ARANDELA	2		FOR CAR ONLY FOR CAR ONLY
5	6X4-83383-00	BUZZER ZUMBADOR	1		FOR CAR ONLY FOR CAR ONLY
6	6X4-83386-00	STAY, BUZZER TIRANTE DE ZUMBADOR	1		FOR CAR ONLY FOR CAR ONLY
7	97780-60620	SCREW, TAPPING TORNILLO DE CABEZA DE CONO ACH	1		FOR CAR ONLY FOR CAR ONLY
8	6Y8-82509-10	WIRE, SUB LEAD CABLE SUBCONDUCTOR	1		FOR CAR ONLY FOR CAR ONLY
9	93210-04279	O-RING ANILLO O	1		FOR CAR ONLY FOR CAR ONLY
10	90465-11M10	CLAMP BRIDA	1		FOR CAR ONLY FOR CAR ONLY
11	6Y8-8454G-00	PATCH 1 PARCHE 1	4		FOR CAR ONLY FOR CAR ONLY
12	90167-06M00	SCREW, TAPPING TORNILLO DE ROSCA HEMBRA	4		UR FOR CAR ONLY UR FOR CAR ONLY
	97880-06035	SCREW, PAN HEAD TORNILLO DE CABEZA CON PLANA	4		UR FOR CAR ONLY UR FOR CAR ONLY
13	90201-06M30	WASHER, PLATE ARANDELA PLANA	8		FOR CAR ONLY FOR CAR ONLY
14	95780-06300	NUT, FLANGE TUERCA	4		FOR CAR ONLY FOR CAR ONLY
15	6Y8-82521-11	2FT PIGTAIL BUS CABLE CONDUCTOR	1		FOR CAR ONLY FOR CAR ONLY
16	6Y8-48277-00	STICKER 1 ETIQUETTE 1	4		FOR CAR ONLY FOR CAR ONLY
17	6H5-81315-00	LEAD WIRE ASSY CABLE CONDUCTOR COMPLETO		1	FOR CAR ONLY FOR CAR ONLY

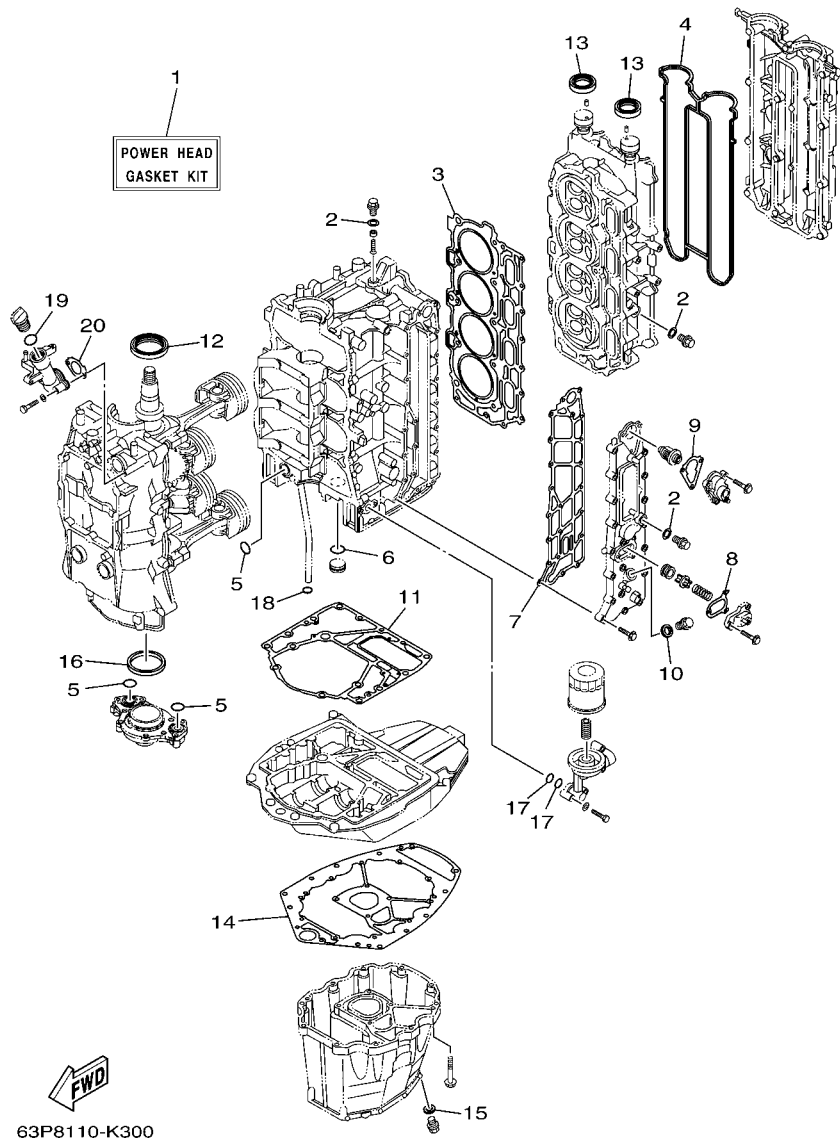


FIG. 40 REPAIR KIT 1

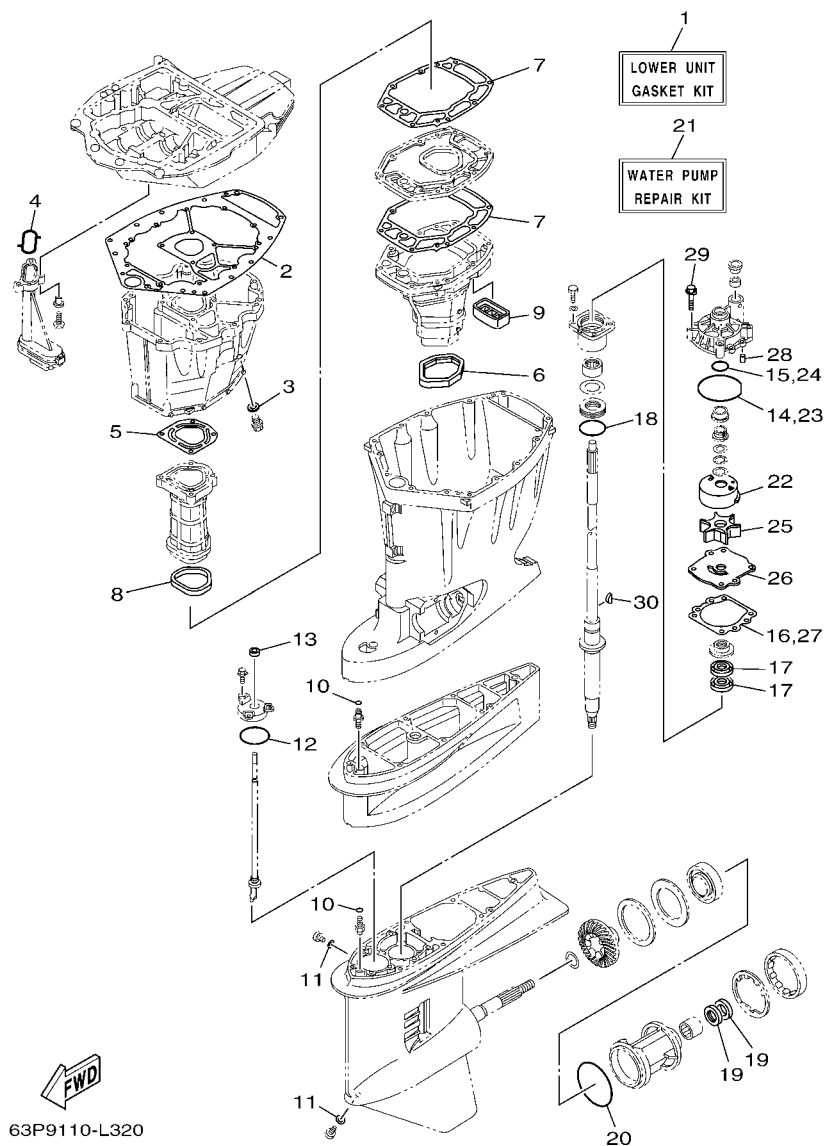
ESTUCHE REPARATION 1

REF. NO.	PART NO. CODIGO Nº	DESCRIPTION DESCRIPCION	63P9	64P9	REMARKS OBSERVACIONES
1	63P-W0001-03	POWER HEAD GASKET KIT JUEGO DE EMPAQUE DE MOTOR	1	1	
2	90430-14115	.GASKET .JUNTA	4	4	
3	63P-11181-00	.GASKET, CYLINDER HEAD 1 .JUNTA, DE CULATA 1	1	1	
4	63P-11193-00	.GASKET, HEAD COVER 1 .EMPAQUE	1	1	
5	93210-25552	.O-RING .ANILLO O	3	3	
6	93210-25647	.O-RING .ANILLO O	1	1	
7	63P-41114-A2	.GASKET, EXHAUST OUTER COVER .EMPAQUE	1	1	
8	67F-12435-A0	.GASKET .EMPAQUE	1	1	
9	63P-12414-00	.GASKET, COVER .EMPAQUE	1	1	
10	90430-18130	.GASKET .JUNTA	1	1	
11	63P-11351-00	.GASKET, CYLINDER .JUNTA, DE CILINDRO	1	1	
12	93102-60008	.OIL SEAL .SELLO ACEITE	1	1	
13	93102-38008	.OIL SEAL .SELLO ACEITE	2	2	
14	63P-15312-00	.GASKET, OIL PAN .EMPAQ BANDEJA DE ACEITE	1	1	
15	90430-14M09	.GASKET .JUNTA	1	1	
16	69J-11355-00	.SEAL, CYLINDER 1 .RETEN ACEITE CILINDRO 1	1	1	
17	93210-19MJ1	.O-RING .ANILLO O	2	2	
18	93210-19MJ3	.O-RING .ANILLO O	1	1	
19	93210-24M79	.O-RING .ANILLO O	1	1	
20	63P-15364-A0	.GASKET, OIL PLUG .EMPAQUE TAPON DE ACEITE	1	1	



FIG. 41 REPAIR KIT 2

ESTUCHE REPARATION 2



63P9110-L320

REF. NO.	PART NO. CODIGO Nº	DESCRIPTION DESCRIPCION	63P9	64P9	REMARKS OBSERVACIONES
1	63P-W0001-20	LOWER UNIT GASKET KIT JUEGO DE EMPAQUE UNIDAD INFER.	1	1	
2	63P-15312-00	.GASKET, OIL PAN .EMPAQ BANDEJA DE ACEITE	1	1	
3	90430-14M09	.GASKET .JUNTA	1	1	
4	63P-13415-00	.SEAL, OIL STRAINER .SELLO COLADOR ACEITE	1	1	
5	63P-41133-A0	.GASKET, EXHAUST MANIFOLD 1 .EMPAQUE ESCAPE MULTIPLE	1	1	
6	69J-45123-00	.GASKET, MUFFLER .EMPAQUE SILENCIADOR	1	1	
7	63P-41134-A0	.GASKET, EXHAUST MANIFOLD .EMPAQUE	2	2	
8	63P-41138-00	.SEAL, EXT. 1 .SELLO, ESCAPE 1	1	1	
9	69J-45127-00	.SEAL .SELLO DE GOMA	1	1	
10	93210-07003	.O-RING .ANILLO O	2	2	
11	90430-08020	.GASKET .JUNTA	2	2	
12	93210-58144	.O-RING .ANILLO O	1	1	
13	93106-09014	.OIL SEAL .SELLO ACEITE	1	1	
14	93210-86M38	.O-RING .ANILLO O	1	1	
15	93210-37160	.O-RING .ANILLO O	1	1	
16	6E5-44315-A0	.GASKET, WATER PUMP .EMPAQUE	1	1	
17	93101-28M16	.OIL SEAL .SELLO ACEITE	2	2	
18	93210-55M14	.O-RING .ANILLO O	1	1	
19	93101-30M17	.OIL SEAL .SELLO ACEITE	2	2	
20	93210-97M55	.O-RING .ANILLO O	1	1	
21	61A-W0078-A3	WATER PUMP REPAIR KIT ESTUCHE REPARACION BOMBA AGUA	1	1	
22	61A-44322-02	.INSERT, CARTRIDGE .CARTUCHO	1	1	
23	93210-86M38	.O-RING .ANILLO O	1	1	
24	93210-37160	.O-RING .ANILLO O	1	1	
25	6E5-44352-01	.IMPELLER .IMPULSOR	1	1	
26	6G5-44323-00	.OUTER PLATE, CARTRIDGE .PLACA EXTERIOR DEL CARTUCHO	1	1	
27	6E5-44315-A0	.GASKET, WATER PUMP .EMPAQUE	1	1	

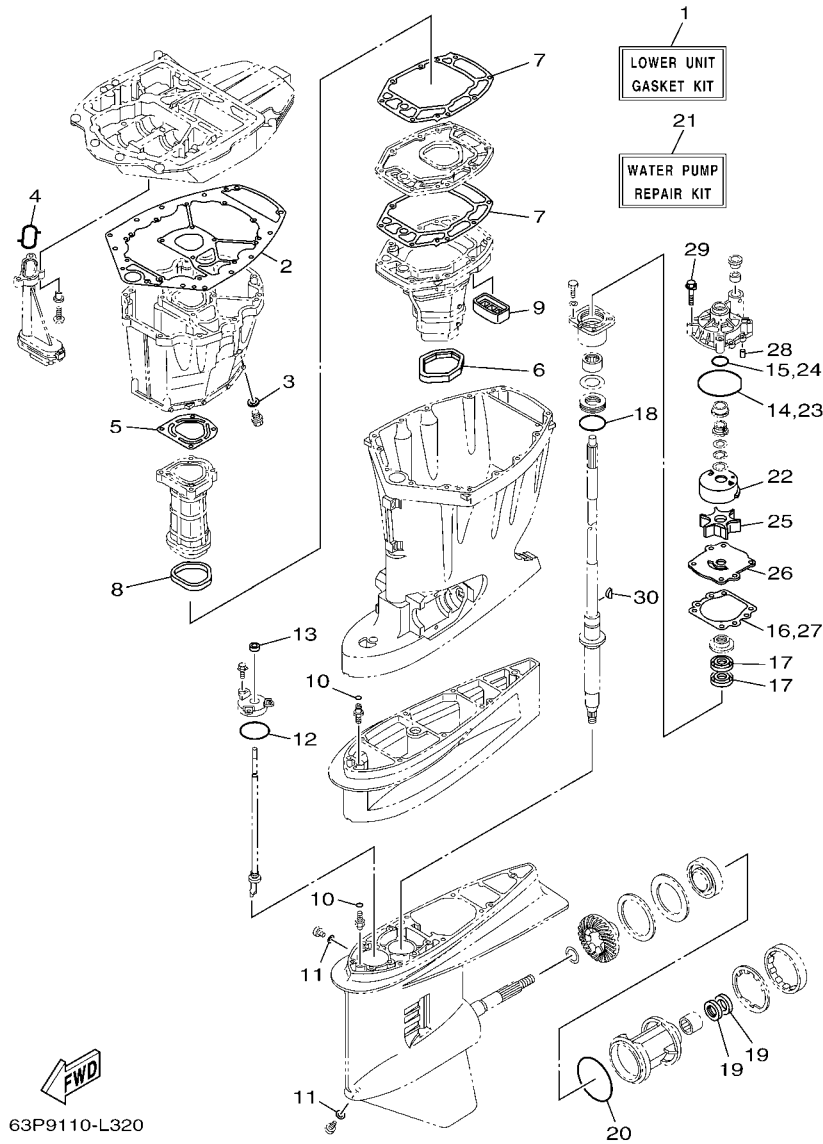


FIG. 41 REPAIR KIT 2

ESTUCHE REPARATION 2

REF. NO.	PART NO. CODIGO Nº	DESCRIPTION DESCRIPCION	63P9	64P9	REMARKS OBSERVACIONES
28	93606-12019	.PIN, DOWEL .PASADOR DE CLAVIJA	2	2	
29	90119-08M14	.BOLT, WITH WASHER .TORNILLO CON ARANDELA	4	4	
30	90280-04M05	.KEY, WOODRUFF .CUNA WOODRUFF	1	1	
-----					
-----					
-----					
-----					
-----					
-----					
-----					
-----					
-----					
-----					

NUMERICAL INDEX  
INDICE NUMERICO

PART NO. CODIGO N°	REF. NO.	PART NO. CODIGO N°	REF. NO.	PART NO. CODIGO N°	REF. NO.	PART NO. CODIGO N°	REF. NO.	PART NO. CODIGO N°	REF. NO.	PART NO. CODIGO N°	REF. NO.
63P-11110-10-9S	4 - 2	63P-11631-10-93	3 - 10	68V-13577-00	11 - 15	68V-14356-00	9 - 10	63P-24311-20	12 - 19	68V-24519-00	11 - 13
63P-11119-00	2 - 22	63P-11633-10	3 - 12	6BM-13593-00	10 - 25	68V-14386-00	10 - 16	63P-24311-30	12 - 19	6P3-24519-00	12 - 11
68F-11119-00	2 - 23	63P-11634-00	3 - 13	69J-13631-00	26 - 15	63P-14435-00	17 - 19	64P-24312-00	8 - 10	6P3-24560-03	12 - 7
6S5-11133-10	4 - 3	63P-11635-10	3 - 10	63P-13641-00	9 - 13	63P-14440-00	7 - 10	63P-24312-10	12 - 35	6P3-24562-03	12 - 9
63P-11135-00	4 - 21	63P-11654-10	3 - 8	63P-13643-00	9 - 22	63P-14446-00	9 - 21	63P-24312-20	12 - 35	6P3-24563-01	12 - 8
63P-11181-00	4 - 16	63P-11656-30	3 - 9	63P-13645-00	9 - 16	68V-14446-00	10 - 28	64P-24313-00	8 - 8	6P3-24564-00	12 - 12
	40 - 3	63P-11656-40	3 - 9	69J-13716-00	10 - 24	63P-14449-00	7 - 11	63P-24313-10	12 - 36	63P-24566-00	12 - 13
63P-11191-00-9S	4 - 20	63P-11656-50	3 - 9	63P-13751-01	9 - 2	63P-14457-00	7 - 12	63P-24313-20	12 - 36	69J-24599-10	11 - 17
63P-11192-01	4 - 27	63P-12111-00	6 - 1	63P-13751-11	9 - 2	63P-14496-00	9 - 14	63P-24314-00	12 - 33	68V-2481H-00	11 - 20
63P-11193-00	4 - 24	6CB-12113-00	6 - 4	6P2-13758-00	11 - 19	63P-14546-01	10 - 15	63P-24314-10	12 - 33	67F-28100-01	12 - 41
	40 - 4	51Y-12119-00	6 - 7	63P-13761-01	9 - 23	63P-14546-10	10 - 15	64P-24314-10	8 - 18	67F-2812A-00	16 - 35
63P-11197-00	2 - 10	63P-12121-00	6 - 2	68V-13766-00	9 - 25	63P-14565-00	10 - 10	63P-24315-00	12 - 34	63P-41113-03-9S	5 - 1
69J-11301-00	4 - 10	63P-12171-10	6 - 9	63P-13769-00	9 - 32	68V-14565-00	9 - 11	64P-24315-00	8 - 13	63P-41114-A2	5 - 4
	5 - 12	63P-12181-10	6 - 10	68V-13781-10	10 - 14	63P-14567-00	10 - 11	63P-24315-10	12 - 34		40 - 7
68T-11325-00	5 - 2	63P-1240H-01-9S	5 - 20	63P-13784-00	10 - 19	3CF-14594-00	9 - 9	63P-24316-00	12 - 6	63P-41131-01-9S	25 - 9
63P-11325-01	2 - 20	67F-12411-01	5 - 18	63P-13784-10	10 - 19	69J-14624-01	25 - 25	64P-24316-00	8 - 14	63P-41133-A0	25 - 10
67F-11325-01	4 - 11	67F-12412-00	5 - 19	63P-13898-00	9 - 31	63P-14711-01-9S	25 - 12	63P-24316-20	12 - 6		41 - 5
	5 - 13	63P-12414-00	5 - 21	63P-13905-00	9 - 30	63P-14777-00	10 - 23	63P-24317-10	11 - 11	63P-41134-A0	25 - 16
	2 - 14		40 - 9	63P-13906-00	10 - 9	63P-14984-00	10 - 13	63P-24317-20	11 - 11		41 - 7
63P-11325-11	2 - 14		40 - 9	63P-13907-03	10 - 18	63P-14984-10	10 - 13	63P-24325-10	11 - 14	63P-41137-02-CA	25 - 1
63P-11325-21	4 - 11	6G5-12416-00	5 - 6	63P-13907-12	10 - 18	63P-14985-00	10 - 17	63P-24325-30	11 - 14	63P-41138-00	25 - 18
67F-11328-00	4 - 12	67F-12435-A0	5 - 10	63P-13915-00	10 - 20	63P-15311-02-CA	26 - 2	6E5-24351-51	13 - 3		41 - 8
	5 - 14		40 - 8	63P-13915-00	10 - 20	63P-15312-00	26 - 1	6Y2-24360-60	13 - 5	63P-41213-00	20 - 43
63P-11351-00	2 - 25	67F-1246A-01-9S	5 - 9	63P-13971-00	11 - 2		40 - 14	6YK-24360-71	13 - 6	63P-41237-00	20 - 49
	40 - 11	68T-12572-00	19 - 29	63P-13974-20	11 - 8		41 - 2	63P-24364-01	8 - 20	6H4-41237-00	9 - 17
69J-11355-00	26 - 16	6R3-12581-00	19 - 31	63P-13974-30	11 - 8	63P-15316-00	26 - 5	63P-24367-01	8 - 12	682-41238-01	9 - 19
	40 - 16	6R3-12582-00	19 - 32	63P-13975-20	11 - 18	63P-15319-00-9S	5 - 35	68V-24374-00	12 - 27	63P-42154-00	20 - 38
63P-11372-00	2 - 4	6R3-12583-00	19 - 33	63P-13975-30	11 - 18	63P-15362-10	26 - 20	6R3-24377-10	12 - 3	63P-42157-00	20 - 50
63P-11377-00	2 - 30	6S5-12858-00	5 - 29	63P-13976-20	11 - 9	6G8-15363-00	5 - 33		12 - 3	68V-42171-00	20 - 51
63P-11410-03	3 - 1	6AW-13119-00	26 - 14	63P-13976-30	11 - 9		5 - 36	6E5-24378-00	12 - 32	66K-42510-02-8D	22 - 9
63P-11416-31	3 - 4	63P-1312A-01	9 - 26	63P-14148-00	10 - 21	63P-15364-A0	40 - 20	69J-24379-00	10 - 22	63P-42541-00	19 - 34
63P-11416-41	3 - 4	63P-13131-00	12 - 24	63P-14149-00	11 - 1		7 - 5	6E5-24379-00	8 - 22	63P-42610-40	1 - 1
63P-11416-51	3 - 4	63P-13160-00	11 - 6	68V-1416A-00	9 - 24	63P-15373-00	26 - 21	63P-24410-10	12 - 21	63P-42613-00	1 - 14
63P-11417-41	3 - 5	63P-13300-02	26 - 12	63P-14180-02	10 - 1	63P-15377-10	7 - 8	68V-24411-00	12 - 26	63P-42615-00	19 - 2
63P-11417-51	3 - 5	63P-13329-00	26 - 13	63P-14180-12	10 - 1	63P-15378-00	8 - 2	68V-24412-00	12 - 22	63P-42617-00	1 - 16
63P-11417-61	3 - 5	63P-13411-00	26 - 8	63P-14181-00	10 - 7	63P-2134X-00	10 - 27	68V-24413-10	12 - 28	63P-42643-01	1 - 11
63P-11417-71	3 - 5	63P-13415-00	26 - 10	63P-14181-10	10 - 7	69J-21841-02	10 - 2	63P-24414-00	12 - 29	63P-42644-00	1 - 13
63P-11417-81	3 - 5		41 - 4	63P-14182-00	10 - 2	35R-22435-A0	23 - 13	63P-24423-00	12 - 25	63P-42647-00	1 - 4
63P-11426-31	3 - 6	67F-13434-20	1 - 26	63P-14182-10	10 - 2	63P-2247B-00	11 - 12	68V-24444-00	12 - 30	60V-42651-01	1 - 7
63P-11426-41	3 - 6	63P-13437-62	14 - 22	63P-14191-00	10 - 8	68V-2411M-00	11 - 10	68V-24452-00	12 - 5	63P-42662-00	1 - 25
63P-11426-51	3 - 6	69J-13440-01	5 - 28	63P-14200-32	9 - 1	63P-2411R-00	10 - 4	4SV-24453-00	10 - 3	68F-42663-00	1 - 12
6CB-11478-00	3 - 2	63P-13446-00-9S	5 - 30	63P-14200-41	9 - 1	63P-2411T-00	10 - 5		10 - 6	69J-42663-00	1 - 8
63P-11500-03	2 - 26	67F-13448-00	1 - 21	63P-14225-00	11 - 7	68V-24149-00	12 - 31	69J-24453-00	10 - 3	63P-42677-40	1 - 17
63P-11512-00	2 - 29	63P-13490-00	2 - 34	69J-14225-01	10 - 12	6P2-24170-00	8 - 1		10 - 6	63P-42678-40	1 - 18
63P-11536-01	6 - 17	63P-13532-10	11 - 5	63P-14291-00	9 - 12	63P-2417H-00	11 - 21		12 - 23	63P-42681-20	1 - 20
63P-11537-00	6 - 12	63P-13545-00	11 - 4	63P-14292-00	9 - 33	63P-2417J-00	11 - 22	68V-24454-00	12 - 10	63P-42710-01-8D	19 - 1
63P-11590-01	6 - 16	63P-13546-00	11 - 3	69J-14321-00	9 - 3	63P-2419A-01	8 - 3	6P3-24469-00	11 - 16	648-42715-00	20 - 29
63P-11603-01	3 - 11	8FP-13556-00	9 - 25	68V-14323-00	9 - 5	6Y2-24307-50	13 - 1	69J-24501-10	8 - 9	63P-42716-00	19 - 36
63P-11604-00	3 - 11	63P-13557-00	9 - 20	68V-14331-00	9 - 4	64P-24311-00	8 - 11				

NUMERICAL INDEX  
INDICE NUMERICO

PART NO. CODIGO N°	REF. NO.	PART NO. CODIGO N°	REF. NO.	PART NO. CODIGO N°	REF. NO.	PART NO. CODIGO N°	REF. NO.	PART NO. CODIGO N°	REF. NO.	PART NO. CODIGO N°	REF. NO.			
61A-42717-00	19 - 28	6CJ-43816-00	23 - 62	63P-44121-00	20 - 17	63P-44556-00-8D	22 - 27	61A-45527-00	27 - 23	6K1-45578-60	29 - 65			
63P-42717-00	19 - 20	6BC-43818-00	21 - 23	63P-44122-00	20 - 14	61A-44575-00	22 - 16	29 - 24	6E5-45587-01	27 - 39				
63P-42718-00	19 - 21	63P-4381J-10	23 - 63	69J-44135-00	20 - 44	63P-45111-00-8D	25 - 20	6G5-45536-01	27 - 9	29 - 40	6E5-45587-10	27 - 39		
69J-42723-01	17 - 22	63P-43820-10	23 - 26	63P-44150-01	27 - 18	69J-45123-00	25 - 13	29 - 10	61A-45538-00	27 - 20	29 - 40	6E5-45587-20	27 - 39	
6E5-42724-00	25 - 8	63P-43821-10	23 - 25	63P-44150-11	27 - 18	41 - 6	61A-45538-00	29 - 21	63P-45551-00	27 - 46	29 - 40	6E5-45587-30	27 - 39	
63P-42725-00	19 - 23	6H1-43822-10	23 - 23	64P-44150-11	29 - 19	69J-45127-00	25 - 19	29 - 21	64P-45560-01	29 - 49	29 - 40	6E5-45587-40	27 - 39	
6H1-42726-21	19 - 25	63P-43828-10	23 - 29	63P-44176-00	20 - 8	41 - 9	63P-45560-01	27 - 46	63P-45560-02	27 - 48	29 - 40	6E5-45587-50	27 - 39	
61A-42727-00	19 - 43	63P-43829-10	23 - 21	61A-44311-01	27 - 24	6C5-45155-00	25 - 28	29 - 47	6G5-45567-01	27 - 5	29 - 40	6E5-45587-60	27 - 39	
63P-42738-00-8D	19 - 19	63P-4382A-10	23 - 32	29 - 25	63P-45181-01-9S	25 - 17	64P-45560-01	29 - 49	6G5-45567-10	27 - 5	29 - 40	6E5-45587-70	27 - 39	
63P-42741-01-8D	19 - 37	63P-43830-10	23 - 45	27 - 29	63P-45211-00-8D	25 - 34	63P-45560-02	27 - 48	6G5-45567-20	27 - 5	29 - 40	6E5-45587-80	27 - 39	
6H4-42748-00	19 - 49	69J-43831-00	23 - 58	28 - 5	6J9-45214-00	28 - 12	6G5-45567-01	27 - 5	6G5-45567-30	27 - 5	29 - 40	6E5-45587-90	27 - 39	
68F-42753-00	19 - 50	6H1-43841-11	23 - 38	29 - 30	30 - 12	30 - 12	6G5-45567-10	27 - 5	6G5-45567-40	27 - 5	29 - 40	6E5-45587-00	27 - 39	
63P-42756-00	19 - 45	63P-43843-10	23 - 50	30 - 5	6J9-45215-00	28 - 13	6G5-45567-20	27 - 5	6G5-45567-50	27 - 5	29 - 40	6E5-45587-10	27 - 39	
6AH-42794-40	19 - 52	6CJ-43844-00	23 - 55	27 - 33	30 - 13	30 - 13	6G5-45567-30	27 - 5	6G5-45567-60	27 - 5	29 - 40	6E5-45587-20	27 - 39	
6AH-42794-50	19 - 53	6H1-43844-10	23 - 49	29 - 34	41 - 16	6G5-45251-02	21 - 2	6G5-45567-40	27 - 5	6G5-45567-70	27 - 5	29 - 40	6E5-45587-30	27 - 39
6AH-42794-70	19 - 52	63P-43845-10	23 - 35	41 - 16	63P-45300-03-8D	27 - 1	6G5-45567-50	27 - 5	6G5-45567-80	27 - 5	29 - 40	6E5-45587-40	27 - 39	
63P-42811-01	19 - 44	63P-43847-10	23 - 30	41 - 27	64P-45300-12-8D	29 - 1	6G5-45567-90	27 - 5	6G5-45567-00	27 - 5	29 - 40	6E5-45587-50	27 - 39	
63P-42815-00-8D	19 - 6	63P-4384G-10	23 - 69	27 - 25	63P-45300-13-8D	27 - 1	6G5-45567-10	27 - 5	6G5-45567-20	27 - 5	29 - 40	6E5-45587-60	27 - 39	
63P-42816-00-8D	19 - 7	6H1-4384G-11	23 - 47	29 - 26	6J9-45301-07-8D	27 - 2	6G5-45567-30	27 - 5	6G5-45567-40	27 - 5	29 - 40	6E5-45587-70	27 - 39	
63P-42818-01	19 - 11	63P-4384H-10	23 - 33	41 - 22	29 - 2	29 - 2	6G5-45567-40	27 - 5	6G5-45567-50	27 - 5	29 - 40	6E5-45587-80	27 - 39	
63P-42828-00-8D	19 - 9	63P-43851-10	23 - 53	27 - 32	6E5-45318-00	25 - 23	6G5-45567-50	27 - 5	6G5-45567-60	27 - 5	29 - 40	6E5-45587-90	27 - 39	
68F-42828-03-8D	19 - 8	63P-43854-10	23 - 31	29 - 33	6E5-45321-00	27 - 14	6G5-45567-70	27 - 5	6G5-45567-80	27 - 5	29 - 40	6E5-45587-00	27 - 39	
64E-43111-02-8D	21 - 1	69J-43855-00	23 - 52	41 - 26	29 - 15	29 - 15	6G5-45567-90	27 - 5	6G5-45567-00	27 - 5	29 - 40	6E5-45587-10	27 - 39	
64E-43112-02-8D	21 - 9	6H1-43856-10	23 - 48	27 - 30	6E5-45331-00-9S	27 - 36	6G5-45567-10	27 - 5	6G5-45567-20	27 - 5	29 - 40	6E5-45587-20	27 - 39	
64E-43126-00	21 - 39	63P-4385H-10	23 - 68	29 - 31	29 - 37	29 - 37	6G5-45567-30	27 - 5	6G5-45567-40	27 - 5	29 - 40	6E5-45587-30	27 - 39	
64E-43131-01	21 - 14	6H1-43861-00	23 - 7	41 - 25	6J9-45332-00-CA	27 - 59	6G5-45567-50	27 - 5	6G5-45567-60	27 - 5	29 - 40	6E5-45587-40	27 - 39	
64E-43139-10	22 - 1	6H1-43862-00	23 - 10	28 - 1	6K1-45332-01-CA	29 - 60	6G5-45567-70	27 - 5	6G5-45567-80	27 - 5	29 - 40	6E5-45587-50	27 - 39	
64D-43144-00	19 - 16	23 - 16	63P-44361-00	30 - 1	688-45341-10	27 - 7	6G5-45567-90	27 - 5	6G5-45567-00	27 - 5	29 - 40	6E5-45587-60	27 - 39	
6G5-43144-00	21 - 29	63P-43862-10	23 - 24	28 - 3	29 - 8	29 - 8	6G5-45567-10	27 - 5	6G5-45567-20	27 - 5	29 - 40	6E5-45587-70	27 - 39	
6E5-43145-01	31 - 8	63P-43863-10	23 - 8	30 - 3	6E5-45344-00	27 - 42	6G5-45567-30	27 - 5	6G5-45567-40	27 - 5	29 - 40	6E5-45587-80	27 - 39	
6G5-43148-00	21 - 34	6H1-43866-01	23 - 42	63P-44363-00	28 - 6	29 - 43	6G5-45567-50	27 - 5	6G5-45567-60	27 - 5	29 - 40	6E5-45587-90	27 - 39	
6G5-43181-02	21 - 31	62X-43871-00	23 - 27	30 - 6	6J9-45371-01	28 - 16	6G5-45567-70	27 - 5	6G5-45567-80	27 - 5	29 - 40	6E5-45587-00	27 - 39	
6G5-43185-02	21 - 32	62Y-43871-00	23 - 64	27 - 28	6K1-45371-02	30 - 16	6G5-45567-90	27 - 5	6G5-45567-00	27 - 5	29 - 40	6E5-45587-10	27 - 39	
64E-43311-10-8D	21 - 25	6H1-43875-00	23 - 37	28 - 2	688-45375-00	27 - 11	6G5-45567-10	27 - 5	6G5-45567-20	27 - 5	29 - 40	6E5-45587-20	27 - 39	
63P-43338-10	23 - 61	63P-43875-10	23 - 22	28 - 4	29 - 12	29 - 12	6G5-45567-30	27 - 5	6G5-45567-40	27 - 5	29 - 40	6E5-45587-30	27 - 39	
63P-43376-00	22 - 6	63P-43876-10	23 - 18	29 - 29	663-45376-00	27 - 10	6G5-45567-50	27 - 5	6G5-45567-60	27 - 5	29 - 40	6E5-45587-40	27 - 39	
63P-43800-10	23 - 1	61A-43878-00	23 - 72	30 - 2	29 - 11	29 - 11	6G5-45567-70	27 - 5	6G5-45567-80	27 - 5	29 - 40	6E5-45587-50	27 - 39	
63P-43801-10	23 - 4	63P-43879-10	24 - 8	30 - 4	63P-45378-00	25 - 35	6G5-45567-90	27 - 5	6G5-45567-00	27 - 5	29 - 40	6E5-45587-60	27 - 39	
63P-43802-10	23 - 39	63P-43880-10	24 - 1	6E5-44366-00	25 - 27	27 - 12	6G5-45567-10	27 - 5	6G5-45567-20	27 - 5	29 - 40	6E5-45587-70	27 - 39	
63P-43804-10	24 - 3	63P-43881-10	24 - 10	6P2-44391-00	19 - 27	29 - 13	6G5-45567-30	27 - 5	6G5-45567-40	27 - 5	29 - 40	6E5-45587-80	27 - 39	
63P-43805-10	24 - 2	63P-4388H-10	23 - 70	63P-44511-00	22 - 36	25 - 32	6G5-45567-50	27 - 5	6G5-45567-60	27 - 5	29 - 40	6E5-45587-90	27 - 39	
63P-4380F-10	24 - 6	63P-43892-10	24 - 4	63P-44514-00	22 - 29	27 - 69	6G5-45567-70	27 - 5	6G5-45567-80	27 - 5	29 - 40	6E5-45587-00	27 - 39	
62X-4380K-00	24 - 7	69J-43899-01	23 - 65	6G5-44526-00	21 - 3	29 - 71	6G5-45567-90	27 - 5	6G5-45567-00	27 - 5	29 - 40	6E5-45587-10	27 - 39	
63P-4380L-10	23 - 2	63P-43899-10	23 - 71	69J-44533-00	22 - 23	27 - 70	6G5-45567-10	27 - 5	6G5-45567-20	27 - 5	29 - 40	6E5-45587-20	27 - 39	
63P-4380P-10	23 - 9	69J-4389J-00	23 - 34	68V-44551-00-8D	22 - 14	29 - 72	6G5-45567-30	27 - 5	6G5-45567-40	27 - 5	29 - 40	6E5-45587-30	27 - 39	
63P-43810-10	23 - 3	63P-44117-00	20 - 9	63P-44553-00-8D	22 - 26	27 - 45	6G5-45567-50	27 - 5	6G5-45567-60	27 - 5	29 - 40	6E5-45587-40	27 - 39	
63P-43811-10	23 - 6	63P-44118-00	20 - 24	60V-44555-00	22 - 17	27 - 45	6G5-45567-70	27 - 5	6G5-45567-80	27 - 5	29 - 40	6E5-45587-50	27 - 39	
63P-43814-10	23 - 15	63P-44120-00	20 - 19	63P-44555-00	22 - 17	29 - 46	6G5-45567-90	27 - 5	6G5-45567-00	27 - 5	29 - 40	6E5-45587-60	27 - 39	

NUMERICAL INDEX  
INDICE NUMERICO

PART NO. CODIGO N°	REF. NO.	PART NO. CODIGO N°	REF. NO.	PART NO. CODIGO N°	REF. NO.	PART NO. CODIGO N°	REF. NO.	PART NO. CODIGO N°	REF. NO.	PART NO. CODIGO N°	REF. NO.
6G5-45976-01	28 - 23	703-48207-1A	33 - 1	703-48243-00	33 - 15	704-48284-P0	35 - 57	67F-81809-00	18 - 19	66K-82149-00	21 - 28
6J9-45976-10	28 - 23	704-48207-P1	32 - 3	703-48244-00	33 - 21	704-48285-10	35 - 65	67F-81810-00	18 - 3	1E6-82151-00	36 - 13
6R1-45976-A0	30 - 23		35 - 1	EL8-48244-00	34 - 30	701-48287-00	33 - 42	67F-81813-00	18 - 6		36 - 13
6R4-45976-A0	28 - 23	703-48211-02	33 - 62		35 - 30	704-48287-00	34 - 20	67F-81820-00	18 - 7	63P-82151-00	16 - 28
6K1-45978-02	30 - 23	703-48212-00	33 - 59	703-48245-00	33 - 11		35 - 20	67F-81821-00	18 - 13	67F-82151-00	16 - 30
6G5-45978-03	28 - 23	703-48213-00	33 - 60	EL8-48245-00	34 - 31	703-48291-10	33 - 39	6K7-81826-11	18 - 24	67F-82151-10	16 - 31
6R1-45978-A0	30 - 23	703-48215-00	33 - 43		35 - 31	703-48293-10	33 - 41	69J-81828-00	18 - 25	63P-82170-00	16 - 27
6R4-45978-A0	28 - 23	704-48215-20	34 - 12	701-48246-00	34 - 5	701-48320-50	32 - 4	68V-8182L-00	9 - 8	68F-82176-00	16 - 36
63P-45987-00	28 - 18	704-48215-30	35 - 12		35 - 5	701-48320-60	32 - 4	67F-81830-00	18 - 17	63P-82181-10	24 - 5
	30 - 18	703-48219-00	33 - 30	703-48246-00	33 - 23	701-48320-80	32 - 4	67F-81832-00	18 - 11	63P-82310-01	15 - 1
688-45997-01	28 - 19	704-48219-P0	34 - 49	701-48248-00	33 - 13	6E5-48344-00	20 - 6	67F-81836-00	18 - 12	663-82317-01	14 - 18
	30 - 19		35 - 49		34 - 38		20 - 36	6C5-81839-00	18 - 21	63P-82341-00	15 - 2
63P-46241-00	6 - 15	703-48221-00	33 - 57		35 - 38	703-48345-01	33 - 19	67F-8183R-00	18 - 16	63P-82342-00	15 - 3
704-48119-31	34 - 59	704-48221-P0	34 - 58	EL8-48251-00	34 - 3		34 - 19	60V-8183T-00	18 - 18	63P-82343-00	15 - 7
704-48119-41	35 - 68		35 - 67		35 - 3		35 - 19	69J-81840-00	18 - 4	63P-82344-01	15 - 8
EL8-48127-00	34 - 23	703-48222-00	33 - 27	703-48252-00	33 - 12	701-48350-00	32 - 4	67F-81841-00	18 - 14	67F-82361-00	15 - 4
	35 - 23	704-48222-P0	34 - 32	EL8-48254-00	34 - 27	701-48350-20	32 - 4	69J-81842-00	18 - 20		15 - 10
704-48128-00	34 - 2		35 - 32		35 - 27	703-48358-00	33 - 20	63P-81845-00	14 - 11	67F-82362-00	15 - 5
	35 - 2	703-48223-00	33 - 28	EL8-48259-00	34 - 7		34 - 24	63P-81845-10	8 - 17		15 - 9
	35 - 62	703-48225-00	33 - 29		35 - 7		35 - 24	67F-81846-00	18 - 26	63P-82380-00	9 - 28
704-48144-10	34 - 50	6X3-48225-20	34 - 43	704-48261-00	34 - 15	63P-48531-00	20 - 1	67F-81850-00	18 - 2	63P-82388-00	15 - 50
704-48144-20	35 - 50		35 - 43		35 - 15	63P-48532-00	20 - 2	67F-81857-00	18 - 9	6Y8-82509-10	39 - 8
703-48152-00	33 - 58	703-48226-00	33 - 26	703-48261-01	33 - 2	63P-48538-00	20 - 4	6C5-81869-00	18 - 23	6R5-82510-02	37 - 4
703-48153-00	33 - 3	703-48227-00	33 - 24	704-48262-00	34 - 8	6E5-61301-01	31 - 10	67F-81891-00	18 - 15	6K1-82510-06	38 - 3
704-48153-00	34 - 55	704-48229-P1	34 - 35		35 - 8	6E5-61303-00	31 - 14	63P-81919-00	16 - 38	703-82510-43	33 - 44
	35 - 55		35 - 35	703-48264-00	33 - 6	6E5-61311-11	31 - 12	60V-81925-00	18 - 28	6Y8-82521-11	39 - 15
704-48156-00	35 - 63	704-48229-P0	35 - 60	704-48264-00	34 - 9	6E5-61313-00	31 - 11	63P-81941-00	18 - 22	703-82531-00	33 - 47
EL8-48164-00	34 - 41	704-48231-00	34 - 25		35 - 9	6E5-61315-00	31 - 13	63P-81942-00	16 - 25		36 - 27
	35 - 41		35 - 25	703-48265-00	33 - 9	6E5-61350-02	31 - 1	63P-81948-00	16 - 13	6K1-82532-00	33 - 46
704-48166-00	34 - 56	703-48232-00	33 - 63	704-48265-00	34 - 4	6E5-61351-01	31 - 2	68F-81949-02	17 - 32		38 - 5
	35 - 56	704-48232-P1	34 - 40		35 - 4	6E5-61355-00	31 - 5	68V-8194A-00	16 - 4	703-82532-00	37 - 6
704-48167-01	34 - 61		35 - 40	703-48268-00	33 - 5	68V-81145-01	9 - 7	63P-81950-00	16 - 9	703-82540-00	33 - 51
704-48167-11	35 - 69	704-48233-00	34 - 53	703-48271-00	33 - 61	68V-81146-01	9 - 27	704-81950-10	35 - 58	704-82540-20	34 - 10
704-48176-00	34 - 51		35 - 53	704-48271-00	34 - 22	68V-81147-00	9 - 29	68V-81953-00	16 - 5	704-82540-30	35 - 10
704-48176-10	35 - 51	703-48234-00	33 - 18		35 - 22	6H5-81315-00	39 - 17	68F-8195A-00	16 - 29	682-82556-00	33 - 49
704-48178-00	35 - 66	704-48234-00	34 - 48	6Y8-48277-00	39 - 16	63P-8132G-00	14 - 19	63P-81960-01	15 - 17		37 - 8
704-48178-10	34 - 60		35 - 48	EL8-48279-00	34 - 47	6P2-81332-00	14 - 15	63P-81975-00	15 - 19		38 - 7
703-48189-00	33 - 17	703-48235-00	33 - 4		35 - 47	63P-81336-00	16 - 37	6K1-81980-00	38 - 18	6P2-82560-01	17 - 26
EL8-48191-00	34 - 16	704-48235-00	34 - 54	703-48281-00	33 - 31	63P-81337-00	14 - 17	6AH-81994-40	14 - 23	69J-82563-00	17 - 21
	35 - 16		35 - 54	704-48281-00	34 - 13	63D-81345-20	14 - 5	6AH-81994-50	14 - 24	703-82563-12	33 - 56
704-48192-00	34 - 44	703-48236-00	33 - 16		35 - 13	63P-81410-00	14 - 4	6AH-81994-70	14 - 23	704-82563-41	34 - 34
	35 - 44	703-48238-00	33 - 22	EL8-48281-00	34 - 11	63P-81450-00	14 - 1	704-81996-00	19 - 54	704-82563-51	35 - 34
704-48192-P0	34 - 52	704-48238-00	34 - 39		35 - 11	63P-81460-00	14 - 2	63P-82105-00	17 - 1	704-82563-H1	35 - 61
	35 - 52		35 - 39	703-48282-00	33 - 32	63P-81673-01	14 - 6	6Y5-82117-00	36 - 14	704-82563-J1	35 - 64
703-48198-00	33 - 14	EL8-48241-00	34 - 26	704-48283-00	34 - 17	6BR-81800-01	18 - 1		36 - 26	6R5-82570-05	37 - 1
704-48205-P1	32 - 2		35 - 26		35 - 17	69J-81801-00	18 - 5	6G5-82119-00	16 - 8	6K1-82570-08	38 - 1
	34 - 1	704-48242-10	34 - 42	703-48284-10	33 - 53	67F-81807-00	18 - 10	6E5-82148-00	21 - 6	6K1-82571-02	38 - 2
703-48207-1A	32 - 1		35 - 42	704-48284-P0	34 - 57	67F-81808-00	18 - 8		21 - 10	704-82571-02	37 - 2

NUMERICAL INDEX  
INDICE NUMERICO

PART NO. CODIGO N°	REF. NO.	PART NO. CODIGO N°	REF. NO.	PART NO. CODIGO N°	REF. NO.	PART NO. CODIGO N°	REF. NO.	PART NO. CODIGO N°	REF. NO.	PART NO. CODIGO N°	REF. NO.
6K1-82575-00	38 - 6	6Y5-8355X-T1	36 - 20	K0F-A3751-E0	6 - 8	90109-14007	22 - 22	90169-05M00	16 - 26	90250-08M07	27 - 56
688-82575-01	33 - 48	6Y5-83570-S5	36 - 6	K0F-A3751-F0	6 - 8	90110-05020	6 - 18	90170-09M05	31 - 19		29 - 57
	37 - 7	63P-83614-01	17 - 24	K0F-A3751-G0	6 - 8	90119-06071	12 - 18	90170-14M06	31 - 15	90280-04M05	27 - 31
676-82577-00	37 - 5	6K1-83614-01	38 - 8	K0F-A3751-H0	6 - 8	90119-06076	7 - 14	90170-16M01	27 - 47		29 - 32
703-82577-00	33 - 45	63P-83626-00	4 - 29	K0F-A3751-J0	6 - 8	90119-06134	15 - 6		29 - 48		41 - 30
	38 - 4	67F-83627-01	18 - 32	K0F-A3751-K0	6 - 8	90119-06135	8 - 25	90171-18M04	28 - 21	90280-05015	14 - 12
64D-82581-00	37 - 9	6AW-83651-00	17 - 20	K0F-A3751-L0	6 - 8		12 - 40		30 - 21	90282-04M00	27 - 68
68F-82582-00	18 - 29	6Y5-83653-30	36 - 15	K0F-A3751-M0	6 - 8	90119-06M10	27 - 17	90179-06M24	1 - 15		29 - 70
6P2-82582-00	17 - 5	6Y5-83653-40	36 - 15	K0F-A3751-N0	6 - 8		29 - 18	90179-08003	18 - 27	90338-25004	2 - 7
6P2-82582-10	17 - 6	63P-8366P-01	17 - 29	K0F-A3751-P0	6 - 8		25 - 33	90179-24002	14 - 14	90340-08002	27 - 6
69J-82587-00	17 - 23	67H-83672-01	22 - 3	K0F-A3751-R0	6 - 8	90119-06M81	2 - 18	90185-05002	28 - 15		29 - 7
63P-82588-00	2 - 35	6Y8-8454G-00	39 - 11	K0F-A3751-S0	6 - 8	90119-06M82	7 - 16		30 - 15	90340-14M06	4 - 8
6E9-82588-00	17 - 27	68F-85119-00	16 - 17	K0F-A3751-T0	6 - 8	90119-06M83	12 - 39	90185-09M01	31 - 6		5 - 26
61A-82588-01	20 - 11	68F-85516-01	16 - 15	K0F-A3753-00	6 - 8	90119-06MA2	2 - 24		31 - 20		26 - 6
6R5-82588-01	37 - 3	60V-85544-00	16 - 34	K0F-A3753-10	6 - 8		5 - 11	90185-14M00	22 - 34	90340-18M09	5 - 23
61B-8258A-01	38 - 24	689-85547-00	12 - 1	K0F-A3753-20	6 - 8	90119-06MA4	5 - 5	90185-22M11	21 - 19	90340-27129	2 - 16
688-8258A-10	17 - 33	68V-85548-00	16 - 23	K0F-A3753-30	6 - 8		5 - 22	90201-06068	19 - 14	90344-51019	4 - 4
688-8258A-20	33 - 50	63P-85580-00	14 - 3	K0F-A3753-40	6 - 8		15 - 18	90201-06M30	39 - 13	90386-06M12	20 - 18
6K1-8258A-40	37 - 18	6Y5-85752-02	36 - 24	K0F-A3753-50	6 - 8	90119-06MA6	2 - 28	90201-06M31	20 - 39	90386-08001	7 - 13
	38 - 23	61A-85790-00	17 - 16	K0F-A3753-60	6 - 8	90119-07234	4 - 7		20 - 45	90386-10M16	21 - 33
704-82590-10	35 - 59	6K1-85830-01	38 - 13	K0F-A3753-70	6 - 8	90119-07235	4 - 6		20 - 52	90386-12069	20 - 31
63P-82590-50	17 - 4	6S1-85885-00	9 - 6	63P-W0001-03	40 - 1	90119-08102	25 - 2	90201-10060	21 - 21	90386-15M73	19 - 12
703-82591-00	33 - 54	63P-85886-00	17 - 18	63P-W0001-20	41 - 1	90119-08M14	27 - 35	90201-10M20	31 - 7	90386-16M66	20 - 21
703-82592-00	33 - 55	63P-8591A-63	16 - 1	63P-W0070-20	1 - 19		29 - 36	90201-10M76	31 - 17	90386-22M98	21 - 24
63P-82594-00	16 - 19	63P-8591A-73	16 - 1	61A-W0078-A3	41 - 21		41 - 29	90201-12426	21 - 45		21 - 40
703-82594-00	33 - 25	6C5-86120-00	8 - 15	63P-W009A-03-9S	4 - 1	90119-08M22	19 - 3	90201-13M01	21 - 44	90386-25M31	21 - 17
704-82594-00	34 - 33	6Y8-86260-11	39 - 2	63P-W009B-10-9S	2 - 1	90119-08M58	25 - 6	90201-15M58	22 - 21	90386-38M32	22 - 12
	35 - 33	6AA-86261-21	39 - 3	63P-W1165-10	3 - 7	90119-08M66	2 - 19	90201-16M01	22 - 33	90387-06010	16 - 14
60V-8259F-00	20 - 32	6Y8-86267-00	39 - 1	63P-W1510-03-9S	2 - 2		2 - 2	90201-16M55	22 - 20	90387-06038	7 - 15
69J-8259F-00	20 - 10	6Y5-87122-S0	36 - 11	90101-09M70	31 - 18	90119-08M91	4 - 19	90201-22M01	27 - 21	90387-06176	16 - 16
63P-8259L-00	10 - 26		36 - 19	90101-12M05	21 - 43	90119-10007	25 - 21		29 - 22	90387-06263	26 - 9
63P-8259M-00	17 - 10	K0F-A3741-00	6 - 5		21 - 43	90119-10008	28 - 11	90201-24014	14 - 13	90387-06M29	20 - 41
68F-82846-00	16 - 32	K0F-A3742-00	6 - 6	90101-12M77	21 - 43		30 - 11	90201-26M59	21 - 18		20 - 54
6R5-83383-00	37 - 13	K0F-A3743-00	6 - 3	90105-06M07	4 - 13	90119-10049	22 - 28	90201-30M92	27 - 67	90387-06M43	19 - 42
6X4-83383-00	39 - 5	K0F-A3751-00	6 - 8		5 - 15	90119-10050	6 - 13	90201-35008	22 - 18	90387-06M60	8 - 5
688-83383-11	38 - 12	K0F-A3751-10	6 - 8	90105-10071	2 - 9	90119-10MA2	28 - 11	90201-38M60	22 - 10		12 - 16
703-83383-11	33 - 52	K0F-A3751-20	6 - 8	90105-10M00	28 - 17	90149-05M05	37 - 14	90202-08M20	20 - 15	90387-06M82	20 - 47
6X4-83386-00	39 - 6	K0F-A3751-30	6 - 8		30 - 17		38 - 19	90202-16061	20 - 22	90387-08M37	19 - 5
6Y5-8350F-00	36 - 18	K0F-A3751-40	6 - 8	90109-06M80	17 - 28		5 - 3	90202-28001	22 - 38	90387-10M05	21 - 36
6Y5-8350T-90	36 - 1	K0F-A3751-50	6 - 8		19 - 40	90151-06M02	2 - 15	90202-32M19	22 - 19	90387-10M61	31 - 3
6Y5-83533-T2	36 - 9	K0F-A3751-60	6 - 8	90109-06M82	19 - 10		2 - 21	90202-40M47	22 - 13	90387-14004	22 - 37
6Y5-83553-00	36 - 12	K0F-A3751-70	6 - 8		19 - 22	90152-05M08	28 - 14	90206-10M04	20 - 40	90430-06M03	4 - 14
6Y5-83553-F1	36 - 23	K0F-A3751-80	6 - 8	90109-06M86	17 - 25		30 - 14		20 - 46		5 - 16
6Y5-83553-M0	36 - 12	K0F-A3751-90	6 - 8		19 - 17	90155-10006	4 - 18		20 - 53	90430-08020	27 - 8
6Y5-83557-10	36 - 16	K0F-A3751-A0	6 - 8		19 - 47	90158-06003	36 - 25	90206-15M18	19 - 13		29 - 9
6E5-83558-00	25 - 29	K0F-A3751-B0	6 - 8		20 - 3	90159-05059	22 - 2	90206-22M19	27 - 22		41 - 11
6Y5-8355X-T1	36 - 5	K0F-A3751-C0	6 - 8	90109-08019	20 - 34	90159-06M28	19 - 39		29 - 23	90430-14115	2 - 13
	36 - 10	K0F-A3751-D0	6 - 8	90109-14005	22 - 32	90167-06M00	39 - 12	90249-06M19	21 - 35		4 - 9

NUMERICAL INDEX  
INDICE NUMERICO

PART NO. CODIGO N°	REF. NO.	PART NO. CODIGO N°	REF. NO.	PART NO. CODIGO N°	REF. NO.	PART NO. CODIGO N°	REF. NO.	PART NO. CODIGO N°	REF. NO.	PART NO. CODIGO N°	REF. NO.
90430-14115	5 - 27	90480-10627	16 - 18	92990-06100	1 - 22	93101-28M16	41 - 17	93210-55M14	29 - 42	93604-29184	23 - 59
	40 - 2	90480-10M23	8 - 4		38 - 16	93101-30M17	27 - 64		41 - 18	93605-10108	6 - 11
90430-14M09	26 - 7		12 - 17	92990-06300	34 - 46		29 - 67	93210-58144	27 - 15	93605-17002	6 - 19
	40 - 15	90480-12314	4 - 28		35 - 46		41 - 19		29 - 16	93606-12019	2 - 3
	41 - 3	90480-13M24	19 - 41	92990-06600	38 - 17	93102-08414	24 - 11		41 - 12		27 - 34
90430-18130	5 - 24	90480-20M05	5 - 8	92990-08600	33 - 34	93102-38008	6 - 14	93210-68N50	23 - 17		29 - 35
	40 - 10	90480-22M81	19 - 4	92990-10600	17 - 17		40 - 13	93210-86M38	27 - 26		41 - 28
90445-070F1	25 - 31	90501-12082	20 - 28	92990-18200	28 - 20	93102-60008	3 - 3		29 - 27	93606-19M23	25 - 15
90445-10027	5 - 25	90501-16M11	5 - 7		30 - 20		40 - 12		41 - 14	93608-16M16	25 - 5
90445-11020	1 - 24	90501-16M37	27 - 52	92995-06100	14 - 9	93106-09014	27 - 16		41 - 23		25 - 22
90445-13511	12 - 2		29 - 53		15 - 13		29 - 17	93210-97M55	27 - 65		25 - 37
90445-13M01	13 - 2	90506-16003	21 - 38		17 - 8		41 - 13		29 - 68		26 - 4
90450-22M14	7 - 6	90506-16M34	19 - 18		17 - 12	93106-19N50	23 - 5		41 - 20		28 - 7
90462-06013	5 - 39	90508-20M31	20 - 30		21 - 5	93210-04279	39 - 9	93306-209U0	27 - 60		30 - 7
90462-10023	7 - 7	90560-12M01	31 - 4	92995-06600	1 - 10	93210-064A5	23 - 51	93311-928U5	27 - 3	93700-06M01	20 - 33
90464-05141	15 - 16	91318-04025	23 - 57		4 - 26		23 - 66		29 - 3	93700-06M03	20 - 35
90464-07M41	15 - 11	91318-05025	23 - 60		5 - 38	93210-07003	25 - 36	93315-425V3	27 - 49		21 - 13
90464-09M31	8 - 19	91318-05040	23 - 43		5 - 41		27 - 13		29 - 50		21 - 27
90464-11012	8 - 21	91490-40030	28 - 22		8 - 7		29 - 14	93315-43061	27 - 63	94702-00391	4 - 30
90464-13M34	12 - 20		30 - 22		12 - 15		41 - 10		29 - 66	95303-05600	37 - 15
90464-16013	2 - 32	91609-16012	23 - 12		14 - 10	93210-07N51	23 - 56	93317-330U2	27 - 38	95303-05700	37 - 12
90464-20006	7 - 9	91690-30010	20 - 5		14 - 21	93210-09165	20 - 20		29 - 39	95333-08600	18 - 33
90464-20181	19 - 46		20 - 26		15 - 14		23 - 20	93332-00048	29 - 61	95380-04600	36 - 4
90464-20258	19 - 51	91690-30020	21 - 37		16 - 3	93210-10M74	23 - 41	93332-000V3	27 - 4		36 - 8
90464-23199	16 - 21	91690-50014	7 - 4		17 - 9	93210-11N52	23 - 19	93341-440U5	29 - 64		36 - 22
	19 - 48	91809-08006	4 - 5		17 - 13	93210-12N52	23 - 40	93341-465U4	29 - 5	95380-05600	33 - 7
90465-08M63	21 - 26	91814-18002	2 - 5		17 - 15	93210-16275	31 - 9	93341-930V2	27 - 40		34 - 21
90465-10032	1 - 2		2 - 6		17 - 31	93210-18397	23 - 36		29 - 41		35 - 21
90465-11M10	8 - 24	92780-06020	34 - 28		21 - 8	93210-19MJ1	5 - 31	93390-000U2	29 - 4		38 - 11
	12 - 4		35 - 28		21 - 12		40 - 17	93410-16006	20 - 23		38 - 20
	12 - 4	92902-06200	23 - 14		26 - 18	93210-19MJ3	26 - 22	93410-22M11	21 - 41	95380-05700	9 - 18
	12 - 37	92903-05100	37 - 11	92995-08100	21 - 16		40 - 18	93410-37M04	22 - 15	95380-06600	1 - 6
	19 - 26		37 - 16	92995-08600	17 - 3	93210-24M79	5 - 34	93420-36M01	25 - 24		1 - 23
	19 - 35	92903-05600	37 - 17		27 - 44		40 - 19	93430-06024	33 - 10		8 - 16
	21 - 20	92903-06600	16 - 12		29 - 45	93210-25552	2 - 17		34 - 6		19 - 38
	22 - 5	92903-08100	18 - 34	92995-10100	25 - 39		26 - 19		35 - 6		33 - 40
	25 - 30	92903-08600	7 - 3		28 - 9		40 - 5	93501-04M02	20 - 27		34 - 37
	36 - 17		18 - 31		30 - 9	93210-25647	2 - 8	93501-08001	23 - 54		35 - 37
	39 - 10	92907-04600	4 - 23	92995-10600	22 - 8		40 - 6		23 - 67		38 - 15
90465-13M18	16 - 22	92990-04100	36 - 3		22 - 31	93210-29375	23 - 28	93503-16003	23 - 46	95380-12600	21 - 46
90465-13M30	19 - 24		36 - 7		25 - 4	93210-30682	12 - 38		27 - 55	95380-14600	22 - 24
90467-09M09	8 - 23		36 - 21		25 - 40	93210-37160	27 - 27		29 - 56	95380-14700	31 - 16
90467-15M14	2 - 31	92990-05100	38 - 10		28 - 10		29 - 28	93505-32038	23 - 11	95780-06300	39 - 14
	2 - 33		38 - 21		30 - 10		41 - 15		23 - 73	95780-10300	22 - 7
90468-18008	20 - 7	92990-05300	34 - 36	92995-14600	22 - 25		41 - 24	93507-32009	27 - 53	95812-06025	26 - 11
	20 - 16		35 - 36		22 - 35	93210-37MH7	22 - 11		29 - 54	95895-06010	21 - 42
	20 - 37	92990-05600	38 - 22	93101-28M16	27 - 37	93210-554A9	24 - 12	93511-32017	27 - 54	95895-06016	26 - 23
90480-06M19	13 - 4	92990-06100	1 - 5		29 - 38	93210-55M14	27 - 41		29 - 55	97013-06020	16 - 11

NUMERICAL INDEX  
INDICE NUMERICO

PART NO. CODIGO N°	REF. NO.	PART NO. CODIGO N°	REF. NO.	PART NO. CODIGO N°	REF. NO.	PART NO. CODIGO N°	REF. NO.	PART NO. CODIGO N°	REF. NO.	PART NO. CODIGO N°	REF. NO.
97013-08020	7 - 2	97595-06516	9 - 15								
97013-08045	18 - 30	97595-06550	20 - 13								
97075-10045	22 - 30	97595-06610	16 - 7								
	25 - 3		16 - 10								
97095-06010	21 - 7	97595-06625	23 - 44								
	21 - 30	97602-04316	24 - 9								
97095-06012	5 - 40	97780-50620	1 - 3								
	17 - 14		16 - 33								
	17 - 30	97780-60520	19 - 30								
97095-06014	12 - 14	97780-60620	16 - 6								
97095-06016	1 - 9		16 - 20								
	8 - 6		16 - 24								
	14 - 20		39 - 7								
	16 - 2	97880-06035	39 - 12								
	17 - 7	97885-06012	21 - 11								
	17 - 11	97885-06016	22 - 4								
97095-06020	19 - 15	97890-05016	34 - 62								
97095-06025	15 - 12		35 - 70								
	20 - 42	97890-05025	34 - 14								
	20 - 55		35 - 14								
97095-06030	4 - 25	97890-06018	34 - 45								
	21 - 4		35 - 45								
97095-06035	14 - 8	97980-06216	25 - 26								
	20 - 48		39 - 4								
97095-06040	26 - 17	97985-04116	20 - 12								
97095-06045	5 - 37	97985-06210	14 - 16								
97095-08016	17 - 2	98507-04008	4 - 22								
97095-08020	21 - 15	98580-03015	33 - 38								
97095-08025	27 - 43	98580-04006	33 - 36								
	29 - 44	98580-04010	33 - 35								
97095-10045	25 - 38	98580-05010	33 - 37								
	28 - 8	98780-05016	2 - 12								
	30 - 8	98780-05018	34 - 29								
97303-05012	37 - 10		35 - 29								
97380-05025	33 - 8	98980-05010	38 - 9								
97380-06018	34 - 18	98980-06020	38 - 14								
	35 - 18	99001-08600	27 - 19								
97380-08030	33 - 33		29 - 20								
97575-06535	20 - 25	99530-08012	14 - 7								
97575-06540	5 - 32	99530-14016	4 - 17								
97575-08535	25 - 14	9E450-04533	36 - 2								
	26 - 3										
97575-08540	4 - 15										
	5 - 17										
	7 - 1										
97575-08560	25 - 11										
97575-10530	21 - 22										
97575-10535	25 - 7										