



**PARTS
CATALOGUE
CATALOGO
DE REPUESTOS**

F75BET'12 (6D68)

F80BET'12 (6D78)

F90BET'12 (6D88)

F100DET'12 (6D98)

F75BET/F80BET
F90BET/F100DET
PARTS CATALOGUE
©2011 by Yamaha Motor Co., Ltd.
1st edition, September 2011
All rights reserved.
Any reprinting or unauthorized use
without the written permission of
Yamaha Motor Co., Ltd.
is expressly prohibited.
Printed in Japan.

F75BET/F80BET
F90BET/F100DET
CATALOGO DE REPUESTOS
©2011 por Yamaha Motor Co., Ltd.
1ª edición, septiembre 2011
Todos los derechos reservados.
Toda reproducción o uso no autorizado
sin el consentimiento escrito de
Yamaha Motor Co., Ltd.
quedan expresamente prohibidos
Impreso en Japón.

FOREWORD

This Parts Catalogue is related to the parts for the model(s) on the cover page. When you are ordering replacement parts, please refer to this Parts Catalogue and quote both part numbers and part names correctly.

1. Modifications or additions which have been made after the issue of the Parts Catalogue will be announced in the Parts News.
It is advisable that you make the necessary corrections to the Parts Catalogue according to the Parts News.

2. Abbreviations

The following abbreviations are used in this Parts Catalogue.

“UR” Use specified parts number.

“UN” Use as many as needed.

“AP” Alternate Parts

“LM” Locally Made (Parts need to be ordered locally)

“F#” Frame No. (Applicable machine No.)

“O/S” Over Size

3. The number of components for assembly

- Parts, which are to be supplied in an assembly, are listed with a dot (.) in front of the part name as shown below.
- The numeral appearing to the right of each component part indicates the quantity of parts for each assembly unit.

PART NO.	DESCRIPTION	Q'TY	REMARKS
2F5-83310-60	FRONT FLASHER LIGHT ASSY	2	
115-83311-60	.BULB (6V-18W)	1	

4. Applicable colours of graphics are represented in the “REMARKS” as shown below.

PART NO.	DESCRIPTION	Q'TY	REMARKS
2N4-24110-00-X5	FUEL TANK COMP.	2	MXR
3J1-24240-10	.GRAPHIC, FUEL TANK	1	FOR MXR

5. Note that the illustrations for reference in finding parts numbers are not to be used for assembling. When assembling, please use the applicable service manual.

6. The asterisk (*) before a reference number indicates modified items after the first edition.

7. Applicable Serial No.

Engine Serial No.

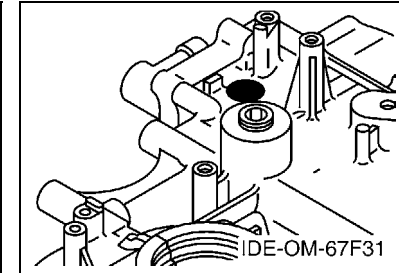
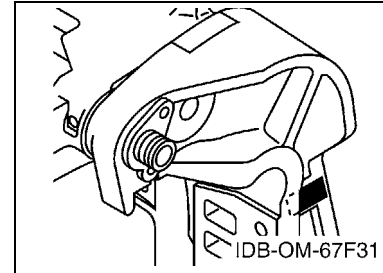

8. Applicable Engine Starting Serial No.

Model	Serial No.	Model	Serial No.
F75B	62P-1013956	F80B	6D7-1013666
F90B	61P-1050228	F100D	6D9-1018900

9. Applicable Colour Code

Abbreviation	Colour Name	Colour Code
DBN1	DARK BLUISH GRAY 1	008D

10. Quantity Column Information

Column No.	Name Of Q'ty Column	Applicable Model
1	6D68	F75BET
2	6D78	F80BET
3	6D88	F90BET
4	6D98	F100DET

PROLOGO

Este catálogo de repuestos corresponde a las piezas para el o los modelos que figuran en la página de portada. Al formular el pedido de repuestos, se ruega citar este catálogo y especificar correctamente el número y el nombre de las piezas.

- Las modificaciones y agregados que se hayan realizado después de la edición de este Catálogo de Repuestos, serán anunciados en las Informaciones de Recambios. Es recomendable que se hagan las correcciones necesarias en el Catálogo de Repuestos de acuerdo con las Informaciones de Recambios.

2. Abreviaciones

En este. Catálogo de Repuestos se emplean las siguientes abreviaciones.

“UR” Usar el número de partes especificado

“UN” Usar la cantidad necesaria

“AP” Piezas sustitutivas

“LM” Fabricación local (Hay que pedir los repuestos en las cercanías)

“F#” N° de bastidor (N° aplicable a la máquina)

“O/S” Sobredimensionado

3. La cantidad de componentes para el montaje

- Los componentes, suministrados como conjunto, se describen con un punto (.) que precede al nombre del parte como se indica a continuación.
- La numeración que aparece a la derecha de cada descripción indica la cantidad de partes por cada unidad de conjunto.

CODIGO N°	DESCRIPCION	CANT.	OBSERVACIONES
2F5-83310-60	ENSAMBLAJE DE LA LUZ	2	
115-83311-60	.BOMBILLA (6V-18W)	1	

4. Los colores de los componentes se indican como sigue en la columna de “OBSERVACIONES”.

CODIGO N°	DESCRIPCION	CANT.	OBSERVACIONES
2N4-24110-00-X5	COMP. DEL TANQUE	2	MXR
3J1-24240-10	.GRAFICO, DEL TANQUE	1	PARA MXR

- Debe tenerse en cuenta que las ilustraciones sirven como guía para la búsqueda de los números de partes y no deben usarse para el montaje. Durante el montaje, se recomienda usar el manual de taller correspondiente.

- EL asterisco (*) antes del número de referencia indica los elementos modificados después de la primera edición.

7. Números de serie

N° de Serie del motor

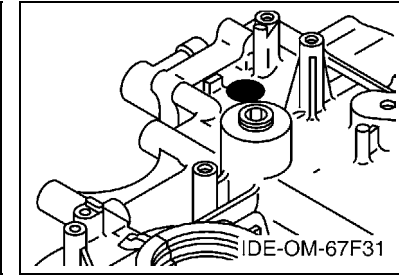
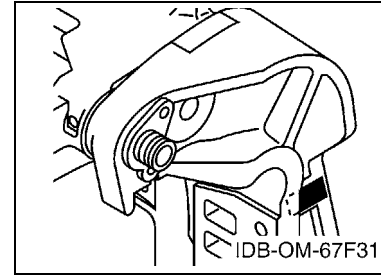

8. Números de serie del motor

Modelo	N° de serie	Modelo	N° de serie
F75B	62P-1013956	F80B	6D7-1013666
F90B	61P-1050228	F100D	6D9-1018900

9. Códigos de color aplicables

Abreviatura	Nombre de color	Código de color
DBN1	DARK BLUISH GRAY 1	008D

10. Información para la columna de cantidades

Columna N°	Nombre de la columna de cantidades	Modelo aplicable
1	6D68	F75BET
2	6D78	F80BET
3	6D88	F90BET
4	6D98	F100DET

CONTENTS

TOP COWLING	1
CYLINDER & CRANKCASE 1	3
CRANKSHAFT & PISTON	5
CYLINDER & CRANKCASE 2	6
VALVE	8
INTAKE 1	10
INTAKE 2	11
INTAKE 3	13
FUEL INJECTION PUMP 1	15
FUEL INJECTION PUMP 2	17
FUEL 1	18
FUEL 2	20
GENERATOR	21
ELECTRICAL 1	23
ELECTRICAL 2	25
ELECTRICAL 3	27
ELECTRICAL 4	29
STARTING MOTOR	30
BOTTOM COWLING	32
CONTROL	34
BRACKET 1	36
BRACKET 2	38
OPTIONAL PARTS 1	40
POWER TRIM & TILT ASSY 1	41
POWER TRIM & TILT ASSY 2	45
UPPER CASING	46
OIL PAN	48
LOWER CASING & DRIVE 1	50
LOWER CASING & DRIVE 2	54
FUEL TANK 1	56
FUEL TANK 2	57
STEERING GUIDE	58
REMOTE CONTROL BOX	59
REMOTE CONTROL ASSY	60
METER	63
OPTIONAL PARTS 2	64
REPAIR KIT 1	65
REPAIR KIT 2	66

INDEX

NUMERICAL INDEX	68
-----------------------	----

CONTENIDO

SOPORTE SUPERIOR	1
CILINDRO & CARTER 1	3
CIGUENAL & PISTON	5
CILINDRO & CARTER 2	6
VALVULA	8
ADMISION 1	10
ADMISION 2	11
ADMISION 3	13
BOMBA DE INYECTOR 1	15
BOMBA DE INYECTOR 2	17
COMBUSTIBLE 1	18
COMBUSTIBLE 2	20
GENERADOR	21
EQUIPO ELECTRICO 1	23
EQUIPO ELECTRICO 2	25
EQUIPO ELECTRICO 3	27
EQUIPO ELECTRICO 4	29
MOTOR DE ARRANQUE	30
CUBIERTA INFERIOR	32
CONTROL	34
SOPORTE 1	36
SOPORTE 2	38
PARTES OPCIONALES 1	40
COMPONER Y PODER VARILLA 1	41
COMPONER Y PODER VARILLA 2	45
FUNDA SUPERIOR	46
OIL PAN	48
IMPULSOR E INFERIOR 1	50
IMPULSOR E INFERIOR 2	54
DEPOSITO DE COMBUSTIBLE 1	56
DEPOSITO DE COMBUSTIBLE 2	57
DIRECCIONGUIAR	58
CONTROL REMOTO COMPLETO	59
CONTROL REMOTO COMPL	60
MEDIDOR	63
PARTES OPCIONALES 2	64
ESTUCHE REPARATION 1	65
ESTUCHE REPARATION 2	66

INDICE

INDICE NUMERICO	68
-----------------------	----

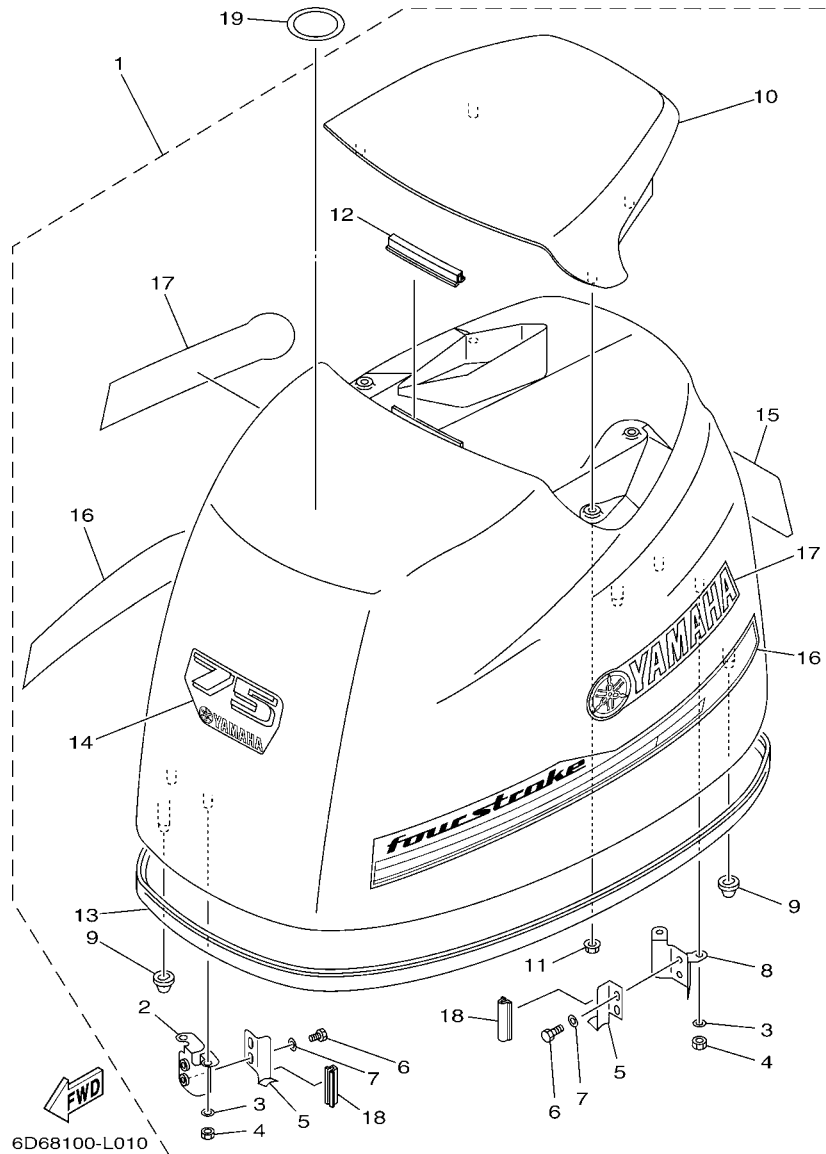

FIG. 1 TOP COWLING

SOPORTE SUPERIOR

REF. NO.	PART NO. CODIGO Nº	DESCRIPTION DESCRIPCION					REMARKS OBSERVACIONES
			6D68	6D78	6D88	6D98	
1	6D6-42610-20	TOP COWLING ASSY SOPORTE SUPERIOR COMPL.	1				
	6D7-42610-20	TOP COWLING ASSY SOPORTE SUPERIOR COMPL.		1			
	6D8-42610-30	TOP COWLING ASSY SOPORTE SUPERIOR COMPL.			1		
	6D9-42610-20	TOP COWLING ASSY SOPORTE SUPERIOR COMPL.				1	
2	67F-42647-00	.HOLDER, CLAMP BAND .MORDAZA DE ABRAZADERA	1	1	1	1	
3	92990-06100	.WASHER, SPRING .ARANDELA PLANA	4	4	4	4	
4	95380-06600	.NUT, HEXAGON .TUERCA	4	4	4	4	
5	68V-42652-00	.HOOK .GANCHO	2	2	2	2	
6	97095-06012	.BOLT .PERNO	4	4	4	4	
7	92995-06600	.WASHER .ARANDELA	4	4	4	4	
8	67F-42649-00	.HOLDER, CLAMP BAND .MORDAZA DE ABRAZADERA	1	1	1	1	
9	67F-42662-00	.DAMPER .AMORTIGUADOR	3	3	3	3	
10	67F-42613-00-8D	.MOLDING, AIR DUCT .MOLDURA CONDUCTO AIRE	1	1	1	1	
11	90179-06M24	.NUT .TUERCA	4	4	4	4	
12	61N-42628-00	.SEAL .SELLO DE GOMA	1	1	1	1	
13	67F-42615-00	.SEAL .SELLO	1	1	1	1	
14	6D6-42677-10	.GRAPHIC, FRONT .CALCAMONIA FRONTAL	1				
	6D7-42677-10	.GRAPHIC, FRONT .CALCAMONIA FRONTAL		1			
	6D8-42677-20	.GRAPHIC, FRONT .CALCAMONIA FRONTAL			1		
	60C-42677-10	.GRAPHIC, FRONT .CALCAMONIA FRONTAL				1	
15	6D6-42678-20	.GRAPHIC, REAR .CALCAMONIA TRASERA	1				
	6D7-42678-20	.GRAPHIC, REAR .CALCAMONIA TRASERA		1			
	6D8-42678-30	.GRAPHIC, REAR .CALCAMONIA TRASERA			1		
	6D9-42678-20	.GRAPHIC, REAR .CALCAMONIA TRASERA				1	
16	6D6-W0070-00	.GRAPHIC SET .JUEGO DE EMBLEMA	1	1	1	1	
17	6D6-42681-00	.MARK, COWLING .MARCA DE CUBIERTA	2	2	2	2	
18	67F-42628-00	.SEAL .SELLO DE GOMA	2	2	2	2	

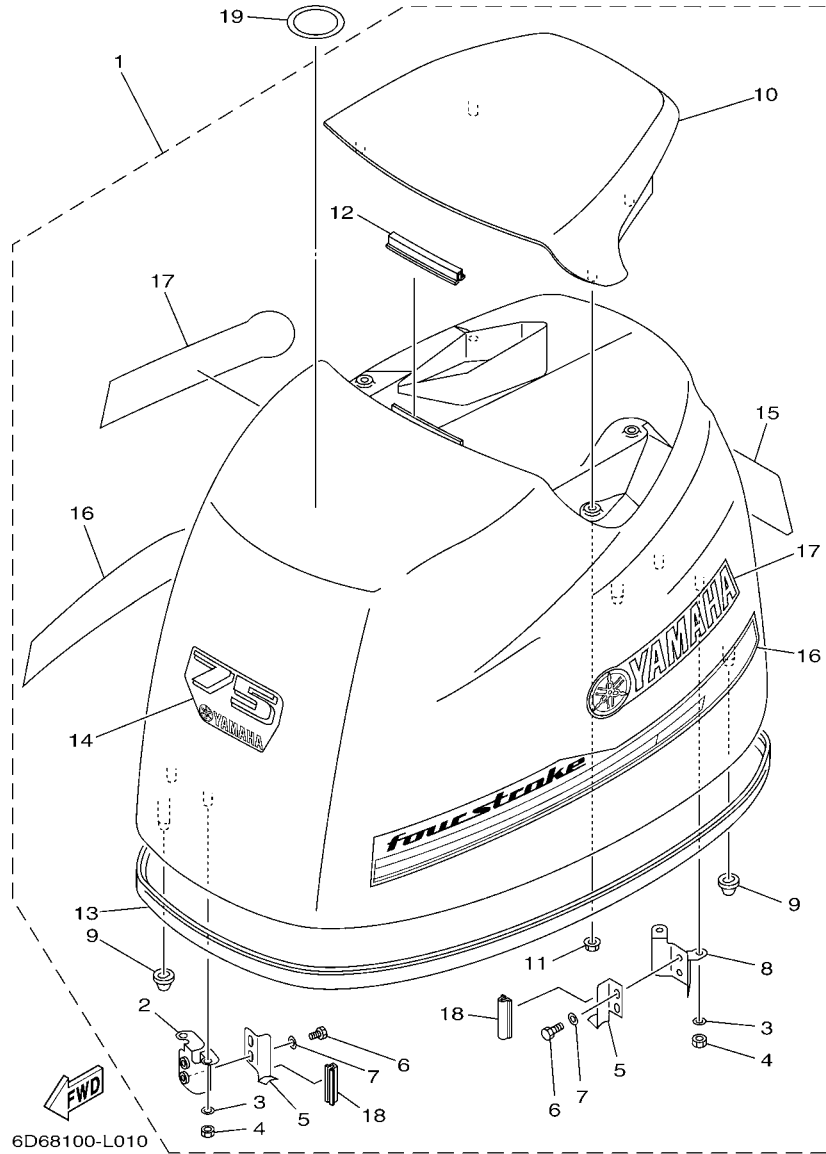

FIG. 1 TOP COWLING

SOPORTE SUPERIOR

REF. NO.	PART NO. CODIGO Nº	DESCRIPTION DESCRIPCION	6D68	6D78	6D88	6D98	REMARKS OBSERVACIONES
19	67F-13434-20	LABEL, CAUTION ETIQUETA DE PRECAUCION	1	1	1	1	

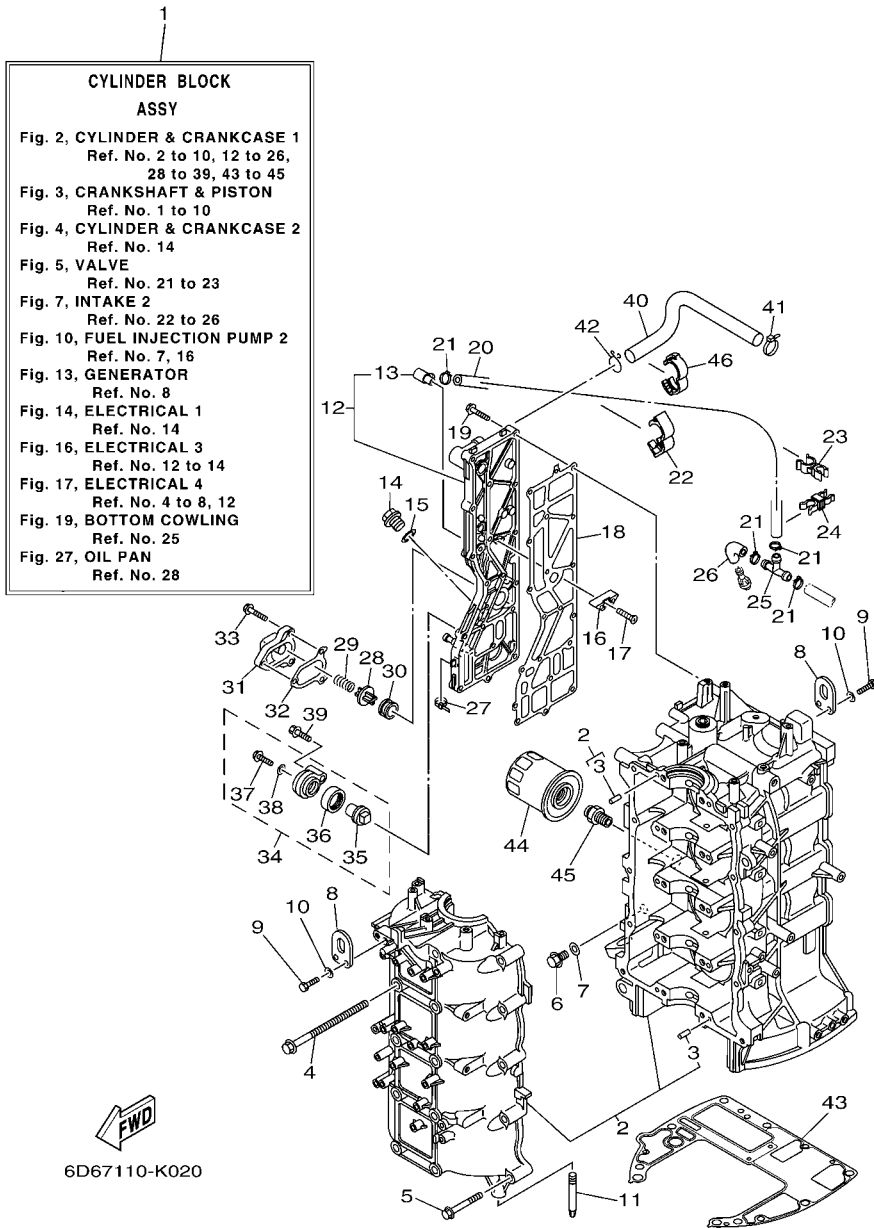

FIG. 2 CYLINDER & CRANKCASE 1 CILINDRO & CARTER 1

REF. NO.	PART NO. CODIGO Nº	DESCRIPTION DESCRIPCION	6D68	6D78	6D88	6D98	REMARKS OBSERVACIONES
1	6D8-W009B-05-9S	CYLINDER BLOCK ASSY CILINDRO BLOQUE COMPLETO	1	1	1	1	
2	6D8-15100-01	CRANKCASE ASSY CARTER COMPLETO	1	1	1	1	
3	93606-12019	.PIN, DOWEL .PASADOR DE CLAVIJA	10	10	10	10	
4	90119-10M88	BOLT, WITH WASHER TORNILLO CON ARANDELA	10	10	10	10	
5	90119-08M66	BOLT, WITH WASHER TORNILLO CON ARANDELA	10	10	10	10	
6	90340-14M06	PLUG, STRAIGHT SCREW TORNILLO, DE DRENAJE	1	1	1	1	
7	90430-14115	GASKET JUNTA	1	1	1	1	
8	62Y-11119-00	HANGER, ENGINE SOPORTE DEL MOTOR	2	2	2	2	
9	97095-06020	BOLT PERNO	4	4	4	4	
10	92995-06600	WASHER ARANDELA	4	4	4	4	
11	67F-15142-00	GUIDE 1 GUIA 1.	2	2	2	2	
12	6D8-41113-40-9S	OUTER COVER, EXHAUST CUBOERTA EXTERIOR DE ESCAPE	1	1	1	1	
13	676-11372-00	.NIPPLE, HOSE .NIPLE DE MANGUERA	1	1	1	1	
14	90340-18M09	PLUG, STRAIGHT SCREW TORNILLO, DE DRENAJE	1	1	1	1	
15	90430-18130	GASKET JUNTA	1	1	1	1	
16	6E5-11325-00	ANODE ANODO	3	3	3	3	
17	98780-04016	SCREW, FLAT HEAD TORNILLO CABEZA PLANA	3	3	3	3	
18	67F-41114-A2	GASKET, EXHAUST OUTER COVER EMPAQUE	1	1	1	1	
19	90119-06MA4	BOLT, WITH WASHER TORNILLO CON ARANDELA	18	18	18	18	
20	6D8-42541-00	PIPE 1 TUBO 1	1	1	1	1	
21	90465-11M10	CLAMP BRIDA	4	4	4	4	
22	90464-18004	CLAMP BRIDA	1	1	1	1	
23	90464-10010	CLAMP BRIDA	1	1	1	1	
24	90464-11009	CLAMP BRIDA	1	1	1	1	
25	688-24378-00	PIPE, JOINT 3 TUBO DE UNION 3	1	1	1	1	
26	61A-24316-00	PIPE 6 TUBO 6	1	1	1	1	
27	90465-11M10	CLAMP BRIDA	1	1	1	1	

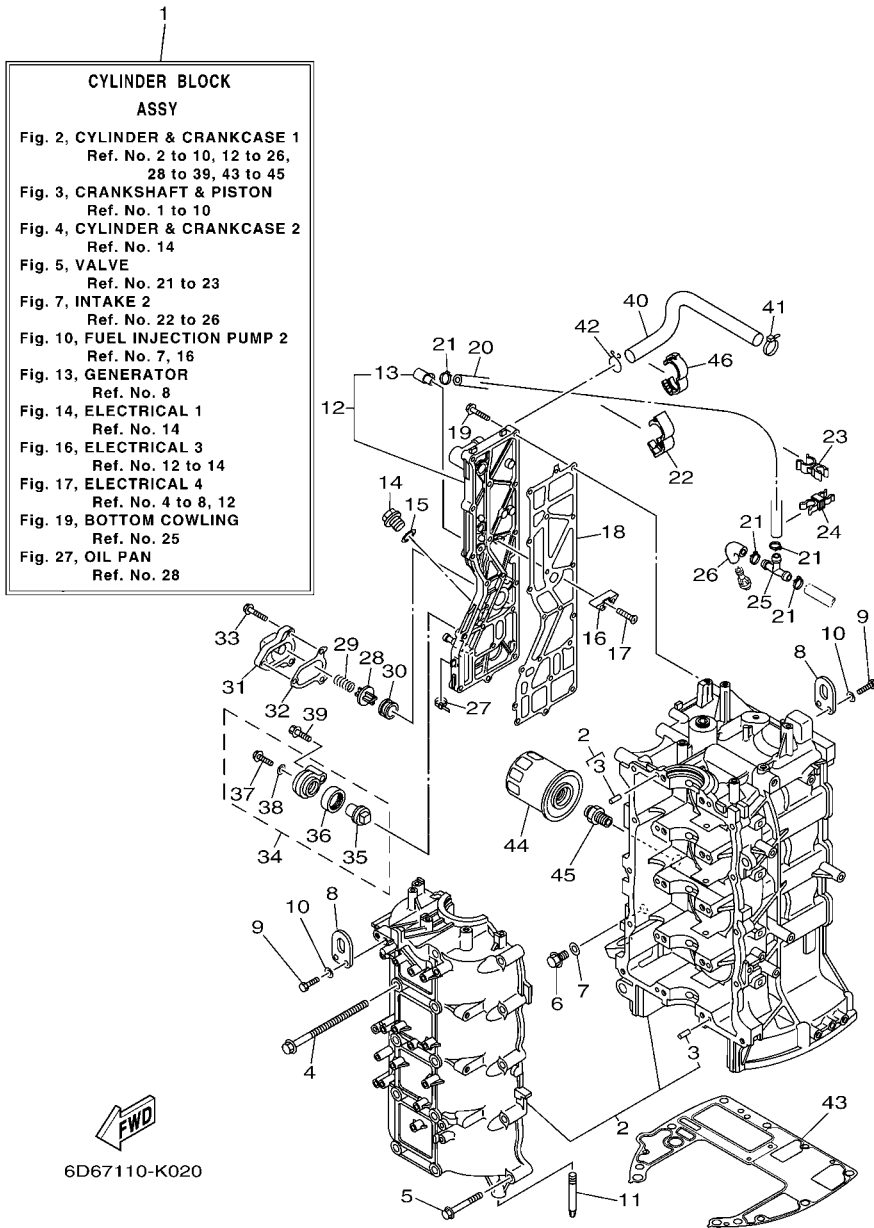
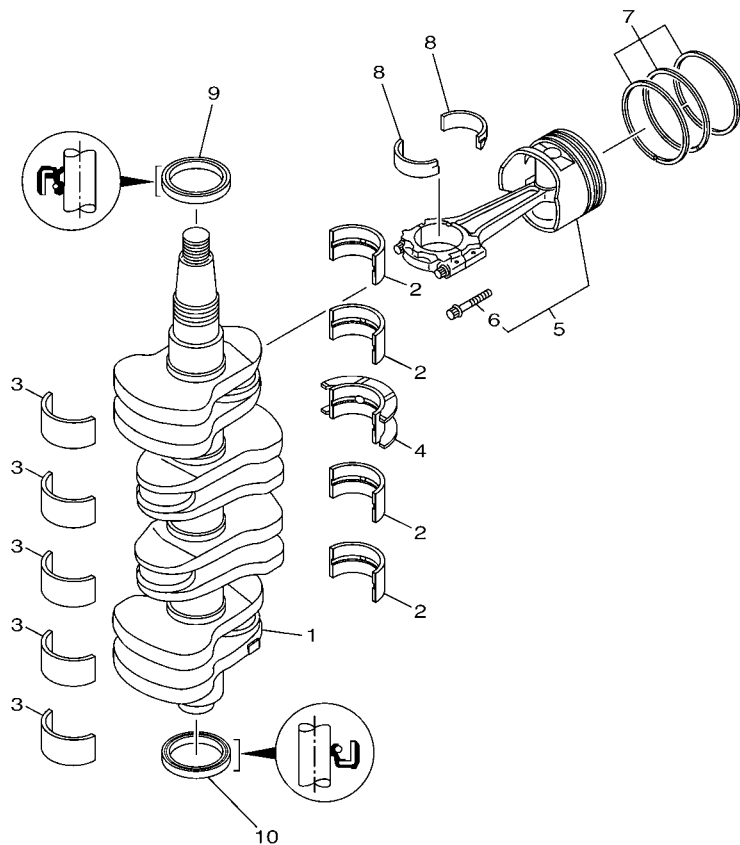

FIG. 2 CYLINDER & CRANKCASE 1 CILINDRO & CARTER 1

REF. NO.	PART NO. CODIGO Nº	DESCRIPTION DESCRIPCION	6D66	6D76	6D86	6D96	REMARKS OBSERVACIONES
28	6G5-12416-00	VALVE, PRESSURE CONTROL VALVULA DE CONTROL DE PRESION	1	1	1	1	
29	90501-16M11	SPRING, COMPRESSION RESORTE DE COMPRESION	1	1	1	1	
30	90480-20M05	GROMMET TAPON	1	1	1	1	
31	67F-1246A-01-9S	COVER 1 CUBIERTA 1	1	1	1	1	
32	67F-12435-A0	GASKET EMPAQUE	1	1	1	1	
33	90119-06MA2	BOLT, WITH WASHER TORNILLO CON ARANDELA	3	3	3	3	
34	69J-11301-00	ANODE COVER ASSY CONJUNTO CUBIERTA DE ANODO	1	1	1	1	
35	67F-11325-01	.ANODE .ANODO	1	1	1	1	
36	67F-11328-00	.GROMMET, ANODE .TAPON	1	1	1	1	
37	90105-06M07	.BOLT, FLANGE .TORNILLO	1	1	1	1	
38	90430-06M03	.GASKET .JUNTA	1	1	1	1	
39	97575-08540	BOLT, WITH WASHER PERNO CON ARANDELA	1	1	1	1	
40	67F-1243A-00	HOSE 1 TUBO 1	1	1	1	1	
41	90465-11M59	CLAMP BRIDA	1	1	1	1	
42	90467-20M15	CLIP PRESILLA	1	1	1	1	
43	68V-11351-00	GASKET, CYLINDER JUNTA, DE CILINDRO	1	1	1	1	
44	5GH-13440-00	ELEMENT ASSY, OIL CLEANER ELEMENTO FILTRO DE ACEITE	1	1	1	1	
45	90401-20007	BOLT, UNION PERNO DE UNION	1	1	1	1	
46	90464-16001	CLAMP BRIDA	1	1	1	1	

FIG. 3 CRANKSHAFT & PISTON

CIGUENAL & PISTON



6D67110-K030

REF. NO.	PART NO. CODIGO N°	DESCRIPTION DESCRIPCION	6D66	6D76	6D86	6D96	REMARKS OBSERVACIONES
1	6D8-11411-00	CRANKSHAFT CIGUENAL	1	1	1	1	
2	6D8-11416-00	PLANE BEARING, CRANKSHAFT 1 COJINETE PLANO 1	4	4	4	4	UR GREEN UR GREEN
	6D8-11416-10	PLANE BEARING, CRANKSHAFT 1 COJINETE PLANO 1	4	4	4	4	UR BLUE UR BLUE
	6D8-11416-20	PLANE BEARING, CRANKSHAFT 1 COJINETE PLANO 1	4	4	4	4	UR RED UR RED
3	6D8-11417-00	PLANE BEARING, CRANKSHAFT 2 COJINETE PLANO 2	5	5	5	5	UR YELLOW UR YELLOW
	6D8-11417-10	PLANE BEARING, CRANKSHAFT 2 COJINETE PLANO 2	5	5	5	5	UR GREEN UR GREEN
	6D8-11417-20	PLANE BEARING, CRANKSHAFT 2 COJINETE PLANO 2	5	5	5	5	UR BLUE UR BLUE
	6D8-11417-30	PLANE BEARING, CRANKSHAFT 2 COJINETE PLANO 2	5	5	5	5	UR RED UR RED
4	6D8-11418-00	PLANE BEARING, CRANKSHAFT 3 COJINETE PLANO 3	1	1	1	1	UR GREEN UR GREEN
	6D8-11418-10	PLANE BEARING, CRANKSHAFT 3 COJINETE PLANO 3	1	1	1	1	UR BLUE UR BLUE
	6D8-11418-20	PLANE BEARING, CRANKSHAFT 3 COJINETE PLANO 3	1	1	1	1	UR RED UR RED
5	6D8-W1164-21	PISTON/CON-ROD ASSY(STD) PISTON/BIELA COMPLETA(NORMA)	4	4	4	4	
	6D8-W1164-31	PISTON/CON-ROD ASSY(0.25MM OS) PISTON/BIELA COMP. (0.25MM OS)	4	4	4	4	AP AP
6	K1C-A3275-00	.BOLT, CONNECTING ROD .TORNILLO DE BIELA	2	2	2	2	
7	6D8-11603-01	PISTON RING SET (STD) JUEGO DE ANILLOS (NORMA)	4	4	4	4	
	6D8-11604-01	PISTON RING SET (0.25MM O/S) JUEGO DE ANILLOS (0.25MM O/S)	4	4	4	4	AP AP
8	6D8-11656-00	PLANE BEARING, CONNECTING ROD COJINETE PLANO	8	8	8	8	UR YELLOW UR YELLOW
	6D8-11656-10	PLANE BEARING, CONNECTING ROD COJINETE PLANO	8	8	8	8	UR GREEN UR GREEN
	6D8-11656-20	PLANE BEARING, CONNECTING ROD COJINETE PLANO	8	8	8	8	UR BLUE UR BLUE
	6D8-11656-30	PLANE BEARING, CONNECTING ROD COJINETE PLANO	8	8	8	8	UR RED UR RED
9	93102-48008	OIL SEAL SELLO ACEITE	1	1	1	1	
10	93101-48001	OIL SEAL SELLO ACEITE	1	1	1	1	

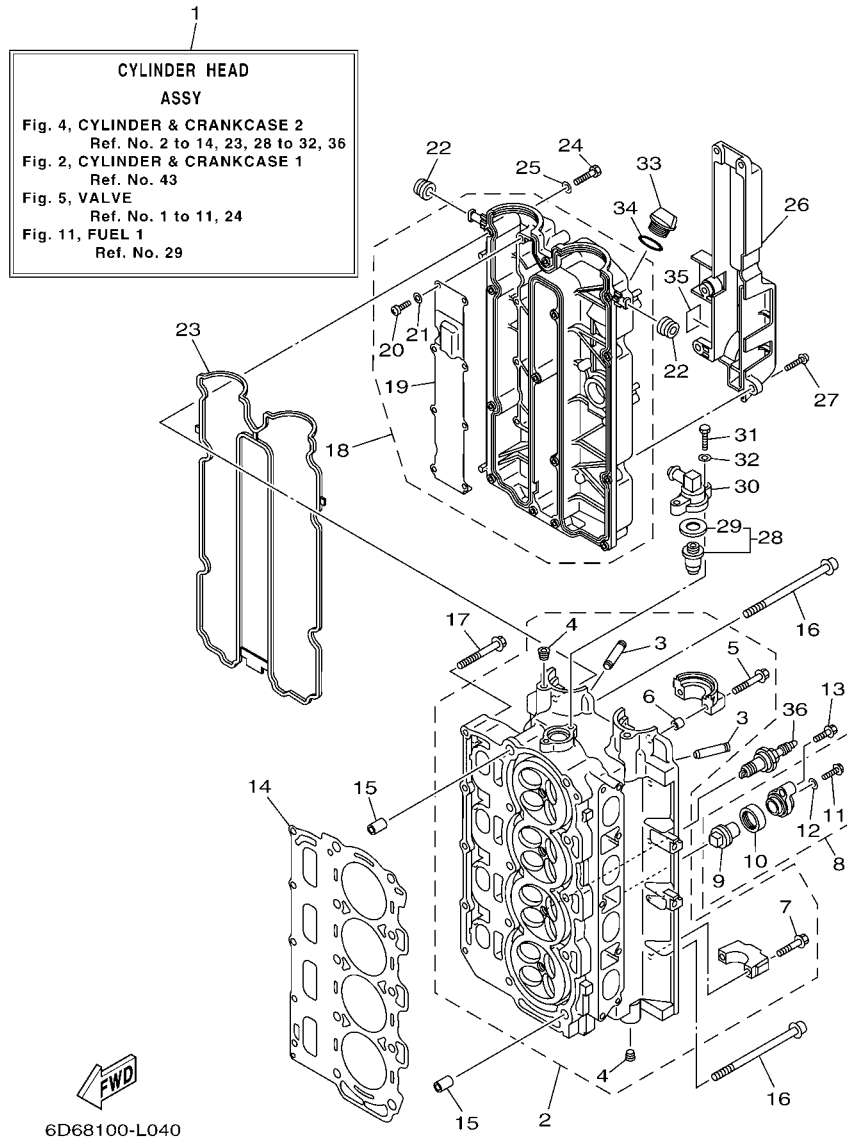

FIG. 4 CYLINDER & CRANKCASE 2 CILINDRO & CARTER 2

REF. NO.	PART NO. CODIGO Nº	DESCRIPTION DESCRIPCION	6D68	6D78	6D88	6D98	REMARKS OBSERVACIONES
1	6D8-W009A-03-9S	CYLINDER HEAD ASSY CILINDRO CULATA COMPLETO	1	1	1		
	6D9-W009A-03-9S	CYLINDER HEAD ASSY CILINDRO CULATA COMPLETO				1	
2	6D8-11110-13-9S	CYLINDER HEAD ASSY CULATA DE CILINDRO COMPLETA	1	1	1	1	
3	67F-11133-10	.GUIDE, VALVE 1 .GUIA DE VALVULA 1	16	16	16	16	
4	90344-51019	.PLUG, TAPER SCREW .TAPON DE TORNILLO AHUSADO	4	4	4	4	
5	90119-07235	.BOLT/WASHER-CAM CAPS .TORNILLO CON ARANDELA	4	4	4	4	
6	91809-08006	.PIN, DOWEL .PASADOR DE CLAVIJA	4	4	4	4	
7	90119-07234	.BOLT, WITH WASHER .TORNILLO CON ARANDELA	16	16	16	16	
8	69J-11301-00	ANODE COVER ASSY CONJUNTO CUBIERTA DE ANODO	2	2	2	2	
9	67F-11325-01	.ANODE .ANODO	1	1	1	1	
10	67F-11328-00	.GROMMET, ANODE .TAPON	1	1	1	1	
11	90105-06M07	.BOLT, FLANGE .TORNILLO	1	1	1	1	
12	90430-06M03	.GASKET .JUNTA	1	1	1	1	
13	97575-08540	BOLT, WITH WASHER PERNO CON ARANDELA	2	2	2	2	
14	67F-11181-03	GASKET, CYLINDER HEAD 1 JUNTA, DE CULATA 1	1	1	1	1	
15	99530-14016	PIN, DOWEL PASADOR, DE ESPIGA	2	2	2	2	
16	90155-10005	SCREW, FLAT FILLISTER TORNILLO CABEZA PLANA RAN.	10	10	10	10	
17	90119-08M91	BOLT, WITH WASHER TORNILLO CON ARANDELA	5	5	5	5	
18	6D8-11191-01-9S	COVER, CYLINDER HEAD 1 TAPA CULATA DE CILINDRO 1	1	1	1	1	
19	67F-11168-00	.COVER, BREATHER .CUBIERTA RESPIRADERO	1	1	1	1	
20	98507-04008	.SCREW, PAN HEAD .TORNILLO DE CABEZA CON PLANA	8	8	8	8	
21	92907-04600	.WASHER .ARANDELA	8	8	8	8	
22	90480-12072	GROMMET TAPON	2	2	2	2	
23	6D8-11356-01	SEAL, CYLINDER 2 RETEN ACEITE CILINDRO 2	1	1	1	1	
24	97095-06030	BOLT PERNO	14	14	14	14	
25	92995-06600	WASHER ARANDELA	14	14	14	14	
26	67F-11192-01	COVER, CYLINDER HEAD 2 TAPA CULATA DE CILINDRO 2	1	1	1	1	

 6D67110-K050

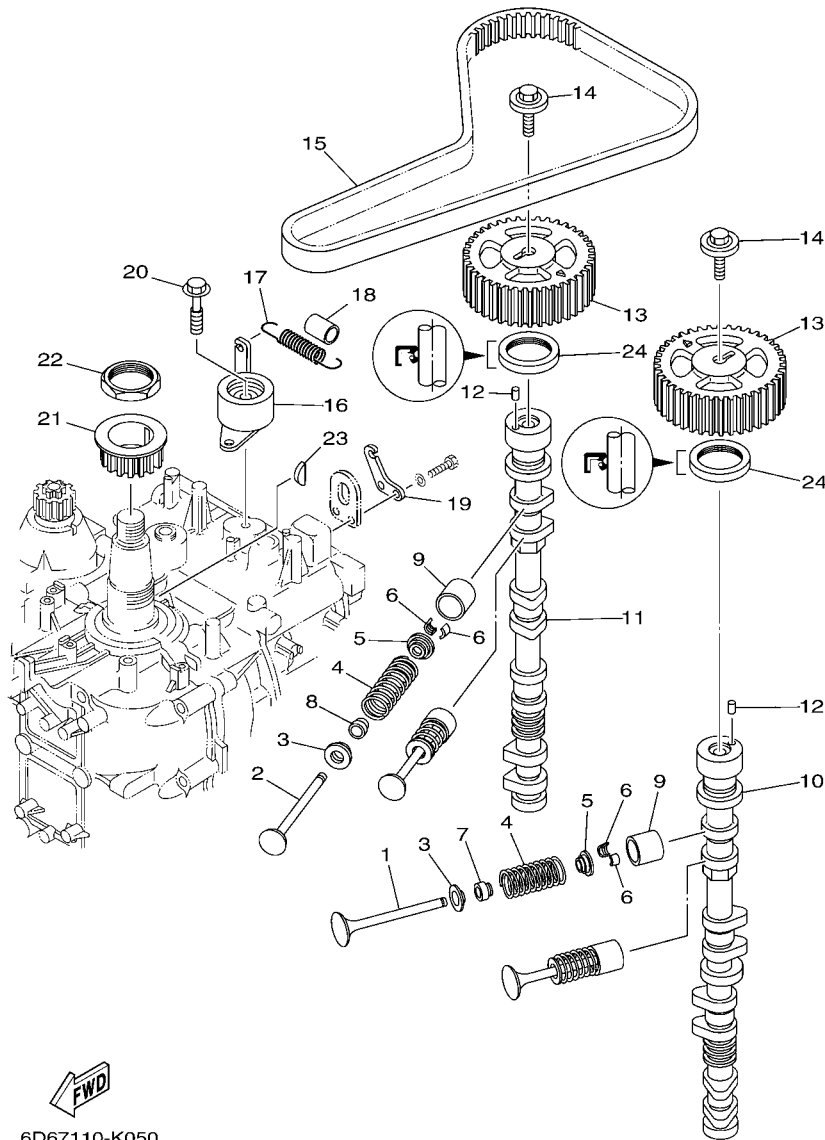

FIG. 5 VALVE

VALVULA

REF. NO.	PART NO. CODIGO Nº	DESCRIPTION DESCRIPCION	6D66	6D76	6D86	6D96	REMARKS OBSERVACIONES
1	6D8-12111-00	VALVE, INTAKE VALVULA DE ADMISION	8	8	8	8	
2	6D8-12121-00	VALVE, EXHAUST VALVULA DE ESCAPE	8	8	8	8	
3	6D8-12116-00	SEAT, VALVE SPRING ASIENTO RESORTE DE VALVULA	16	16	16	16	
4	6D8-12113-00	SPRING, VALVE INNER RESORTE VALVULA INTERNA	16	16	16	16	
5	26H-12117-00	RETAINER, VALVE SPRING RETEN RESORTE DE VALVULA	16	16	16	16	
6	4G0-12118-00	COTTER, VALVE SEGURO DE VALVULA	32	32	32	32	
7	K0A-A3721-00	SEAL, VALVE STEM SELLO DE ACEITE VALVULA	8	8	8	8	
8	K0A-A3722-00	SEAL, VALVE STEM 2 SELLO DE ACEITE VALVULA 2	8	8	8	8	
9	6D8-12153-00	LIFTER, VALVE (12) LEVANTADOR DE VALVULA (12)	16	16	16	16	UR
	6D8-12153-10	LIFTER, VALVE (14) LEVANTADOR DE VALVULA (14)	16	16	16	16	UR
	6D8-12153-20	LIFTER, VALVE (16) LEVANTADOR DE VALVULA (16)	16	16	16	16	UR
	6D8-12153-30	LIFTER, VALVE (18) LEVANTADOR DE VALVULA (18)	16	16	16	16	UR
	6D8-12153-40	LIFTER, VALVE (20) LEVANTADOR DE VALVULA (20)	16	16	16	16	UR
	6D8-12153-50	LIFTER, VALVE (22) LEVANTADOR DE VALVULA (22)	16	16	16	16	UR
	6D8-12153-60	LIFTER, VALVE (24) LEVANTADOR DE VALVULA (24)	16	16	16	16	UR
	6D8-12153-70	LIFTER, VALVE (26) LEVANTADOR DE VALVULA (26)	16	16	16	16	UR
	6D8-12153-80	LIFTER, VALVE (28) LEVANTADOR DE VALVULA (28)	16	16	16	16	UR
	6D8-12153-90	LIFTER, VALVE (30) LEVANTADOR DE VALVULA (30)	16	16	16	16	UR
	6D8-12153-A0	LIFTER, VALVE (32) LEVANTADOR DE VALVULA (32)	16	16	16	16	UR
	6D8-12153-B0	LIFTER, VALVE (34) LEVANTADOR DE VALVULA (34)	16	16	16	16	UR
	6D8-12153-C0	LIFTER, VALVE (36) LEVANTADOR DE VALVULA (36)	16	16	16	16	UR
	6D8-12153-D0	LIFTER, VALVE (38) LEVANTADOR DE VALVULA (38)	16	16	16	16	UR
	6D8-12153-E0	LIFTER, VALVE (40) LEVANTADOR DE VALVULA (40)	16	16	16	16	UR
	6D8-12153-F0	LIFTER, VALVE (42) LEVANTADOR DE VALVULA (42)	16	16	16	16	UR
	6D8-12153-G0	LIFTER, VALVE (44) LEVANTADOR DE VALVULA (44)	16	16	16	16	UR
	6D8-12153-H0	LIFTER, VALVE (46) LEVANTADOR DE VALVULA (46)	16	16	16	16	UR
	6D8-12153-J0	LIFTER, VALVE (48) LEVANTADOR DE VALVULA (48)	16	16	16	16	UR

6D67110-K050

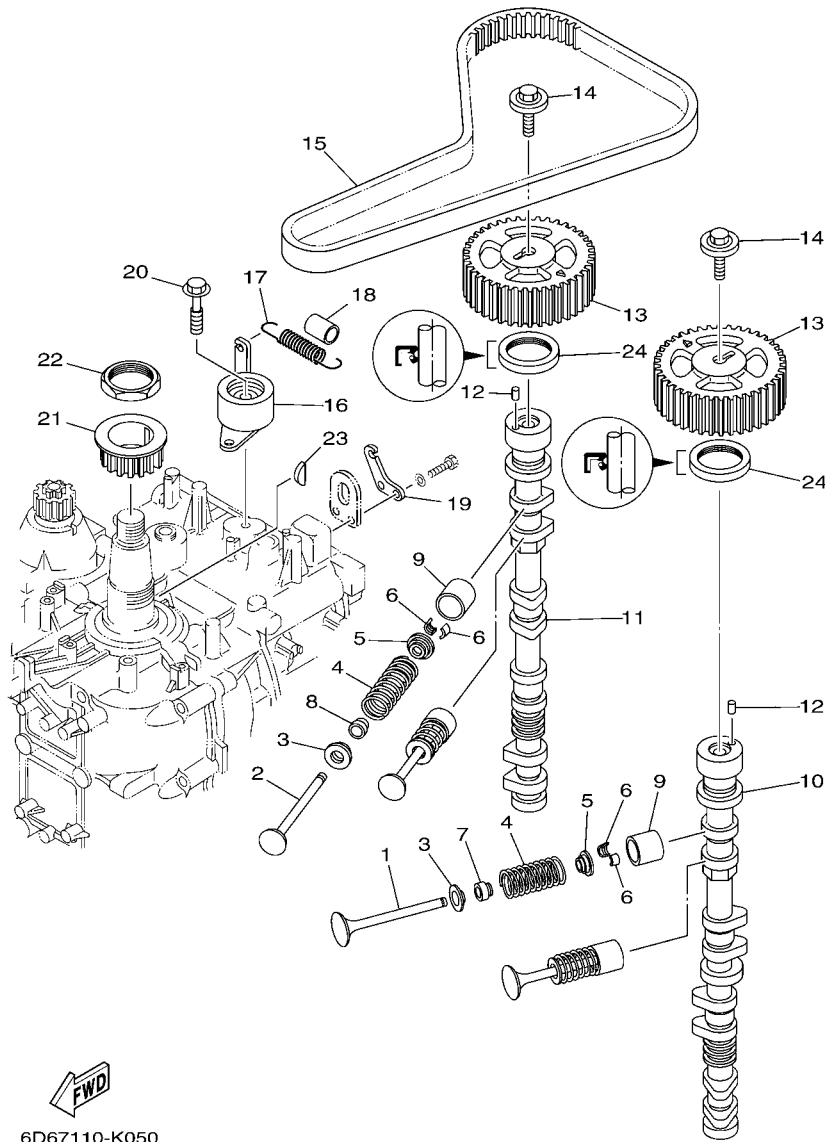

FIG. 5 VALVE

VALVULA

REF. NO.	PART NO. CODIGO Nº	DESCRIPTION DESCRIPCION	6D68	6D78	6D88	6D98	REMARKS OBSERVACIONES
9	6D8-12153-K0	LIFTER, VALVE (50) LEVANTADOR DE VALVULA (50)	16	16	16	16	UR UR
	6D8-12153-L0	LIFTER, VALVE (52) LEVANTADOR DE VALVULA (52)	16	16	16	16	UR UR
	6D8-12153-M0	LIFTER, VALVE (54) LEVANTADOR DE VALVULA (54)	16	16	16	16	UR UR
	6D8-12153-N0	LIFTER, VALVE (56) LEVANTADOR DE VALVULA (56)	16	16	16	16	UR UR
	6D8-12153-P0	LIFTER, VALVE (58) LEVANTADOR DE VALVULA (58)	16	16	16	16	UR UR
	6D8-12153-R0	LIFTER, VALVE (60) LEVANTADOR DE VALVULA (60)	16	16	16	16	UR UR
	6D8-12153-S0	LIFTER, VALVE (62) LEVANTADOR DE VALVULA (62)	16	16	16	16	UR UR
	6D8-12153-T0	LIFTER, VALVE (64) LEVANTADOR DE VALVULA (64)	16	16	16	16	UR UR
	6D8-12153-U0	LIFTER, VALVE (66) LEVANTADOR DE VALVULA (66)	16	16	16	16	UR UR
	6D8-12153-V0	LIFTER, VALVE (68) LEVANTADOR DE VALVULA (68)	16	16	16	16	UR UR
10	6D8-12171-00	CAMSHAFT 1 ARBOL DE LEVAS 1	1	1	1		
	6D9-12171-00	CAMSHAFT 1 ARBOL DE LEVAS 1				1	
11	6D8-12181-00	CAMSHAFT 2 ARBOL DE LEVAS 2	1	1	1	1	
12	93605-10108	PIN, DOWEL PASADOR DE CLAVIJA	2	2	2	2	
13	67F-11537-00	GEAR, DRIVEN ENGRANAJE TRACCION	2	2	2	2	
14	90119-10050	BOLT, WITH WASHER TORNILLO CON ARANDELA	2	2	2	2	
15	67F-46241-00	BELT CORREA	1	1	1	1	
16	67F-11590-00	TENSIONER ASSY TENSOR COMPLET	1	1	1	1	
17	90506-16M39	SPRING, TENSION RESORTE DE TENSION	1	1	1	1	
18	90445-15M03	HOSE (L23) TUBO (L23)	1	1	1	1	
19	67F-11595-00	PLATE, VALVE PLACA DE VALVULA	1	1	1	1	
20	90119-10M72	BOLT, WITH WASHER TORNILLO CON ARANDELA	1	1	1	1	
21	6D8-11536-00	GEAR, DRIVE ENGRANAJE TRACCION	1	1	1	1	
22	90170-40008	NUT TUERCA	1	1	1	1	
23	90280-04008	KEY, WOODRUFF CUNA WOODRUFF	1	1	1	1	
24	93102-38008	OIL SEAL SELLO ACEITE	2	2	2	2	

FIG. 6 INTAKE 1

ADMISION 1

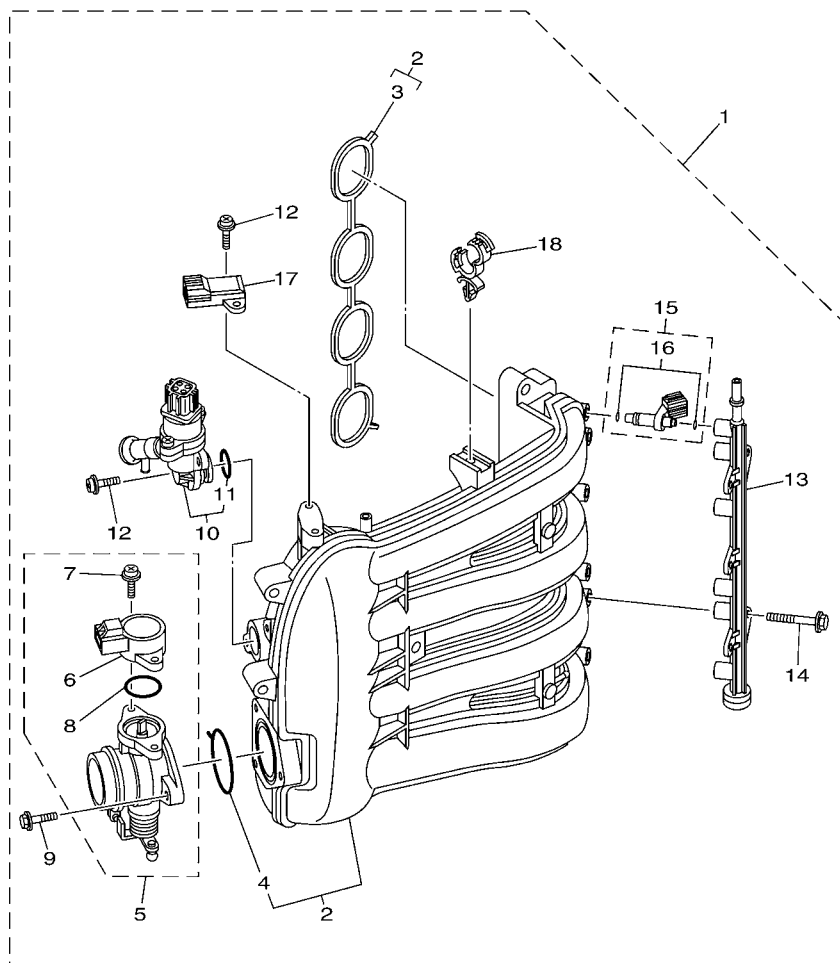

6D81100-D060

REF. NO.	PART NO. CODIGO Nº	DESCRIPTION DESCRIPCION	6D66	6D76	6D86	6D96	REMARKS OBSERVACIONES
1	6D8-14200-00	INTAKE ASSY ADMISION COMPL.	1	1	1	1	
2	6D8-13641-00	.MANIFOLD, INTAKE 1 .CONECTOR DE ADMISION 1	1	1	1	1	
3	6D8-13645-00	..GASKET, MANIFOLD 1 ..EMPAQUE	1	1	1	1	
4	6D8-13557-00	..GASKET ..EMPAQUE	1	1	1	1	
5	6D8-13750-00	.THROTTLE BODY ASSY .CAJA DE ACELERADOR COMPL.	1	1	1	1	
6	6C5-85885-00	..THROTTLE SENSOR ASSY ..TERMICA SENSORIO	1	1	1	1	
7	6C5-81145-00	..SCREW 1 ..TORNILLO 1	2	2	2	2	
8	6C5-8182L-00	..O-RING 1 ..ANILLO EN O	1	1	1	1	
9	6C5-14496-00	.BOLT .PERNO	3	3	3	3	
10	6D8-13105-01	.CONTROL VALVE ASSY .VALVULA DE CONTROL COMPLET	1	1	1	1	
11	6C5-14397-00	..O-RING ..ANILLO O	1	1	1	1	
12	6C5-81146-00	.SCREW 2 .TORNILLO 2	4	4	4	4	
13	6D8-13161-00	.PIPE, DELIVERY 1 .TUBO CONDUCTOR 1	1	1	1	1	
14	6C5-14446-00	.BOLT .PERNO	2	2	2	2	
15	6D8-13761-00	.INJECTOR .INYECTOR	4	4	4	4	
16	6C5-1410B-00	..PACKING KIT ..JUEGO DE EMPAQUE	1	1	1	1	
17	68F-83688-00	.SENSOR ASSY .SENSOR COMP.	1	1	1	1	
18	90464-18246	.CLAMP .BRIDA	1	1	1	1	

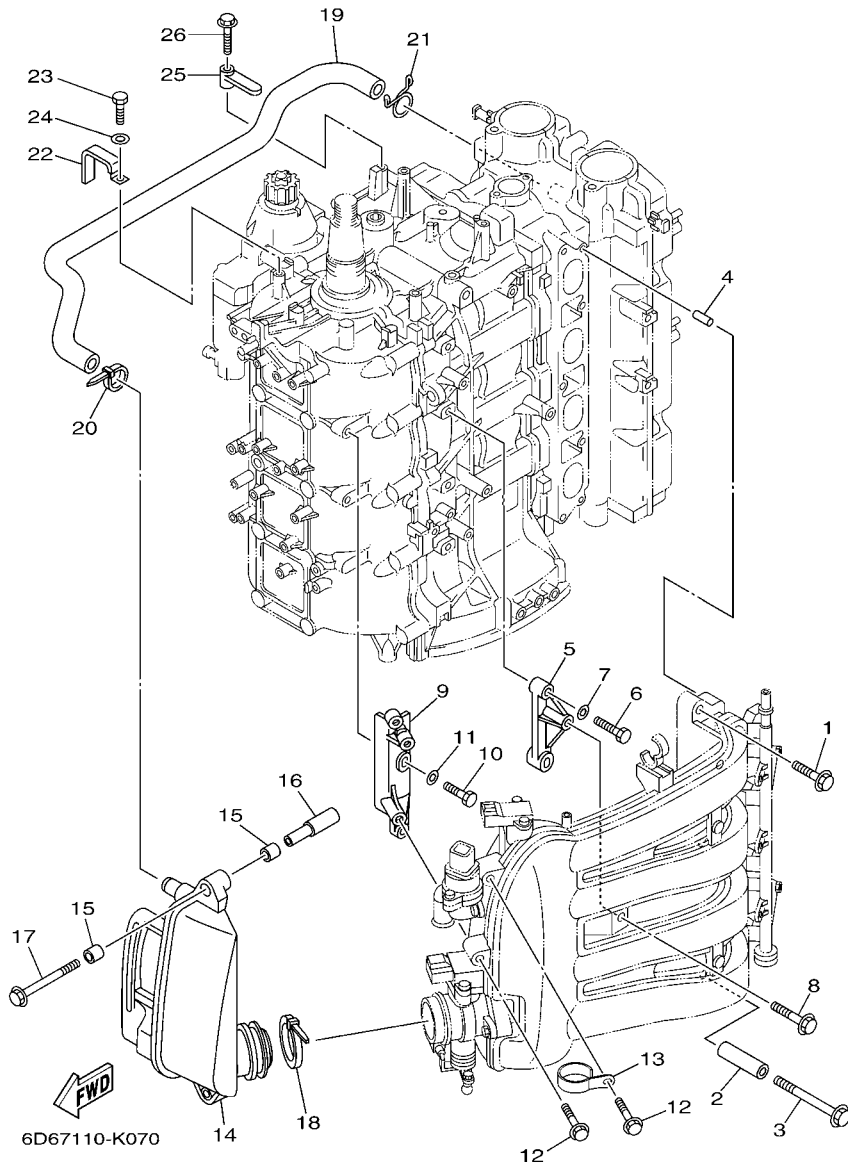

FIG. 7 INTAKE 2

ADMISION 2

REF. NO.	PART NO. CODIGO Nº	DESCRIPTION DESCRIPCION	6D66	6D76	6D88	6D98	REMARKS OBSERVACIONES
1	90119-08069	BOLT, WITH WASHER TORNILLO CON ARANDELA	4	4	4	4	
2	90387-08033	COLLAR ESPACIADOR	1	1	1	1	
3	90119-08M03	BOLT, WITH WASHER TORNILLO CON ARANDELA	1	1	1	1	
4	91690-50014	PIN, SPRING PASADOR DE RESORTE	2	2	2	2	
5	6D8-14291-00	BRACKET 1 SOPORTE 1	1	1	1	1	
6	97095-06030	BOLT PERNO	2	2	2	2	
7	92995-06600	WASHER ARANDELA	2	2	2	2	
8	90119-06087	BOLT, WITH WASHER TORNILLO CON ARANDELA	1	1	1	1	
9	6D8-14292-00	BRACKET 2 SOPORTE 2	1	1	1	1	
10	97095-06020	BOLT PERNO	2	2	2	2	
11	92995-06600	WASHER ARANDELA	2	2	2	2	
12	90119-06087	BOLT, WITH WASHER TORNILLO CON ARANDELA	2	2	2	2	
13	6D8-13782-00	STAY SOPORTE	1	1	1	1	
14	6D6-14440-00 6D8-14440-01 6D9-14440-01	SILENCER ASSY, INTAKE SILENCIADOR COMPL DE ADMISION SILENCIADOR ASSY, INTAKE SILENCIADOR COMPL DE ADMISION SILENCER ASSY, INTAKE SILENCIADOR COMPL DE ADMISION	1	1	1	1	
15	90386-08001	BUSH BUJE	4	4	4	4	
16	90387-07013	COLLAR ESPACIADOR	2	2	2	2	
17	90119-06113	BOLT, WITH WASHER TORNILLO CON ARANDELA	2	2	2	2	
18	90464-76001	CLAMP BRIDA	1	1	1	1	
19	6D8-15373-00	PIPE, BREATHER MANGUELA DE RESPIRADERO	1	1	1	1	
20	90465-11M59	CLAMP BRIDA	1	1	1	1	
21	90467-20M15	CLIP PRESILLA	1	1	1	1	
22	90465-12M03	CLAMP BRIDA	1	1	1	1	
23	97095-06012	BOLT PERNO	1	1	1	1	
24	92995-06600	WASHER ARANDELA	1	1	1	1	
25	6D8-82544-00	CLAMP GRAMPA	1	1	1	1	

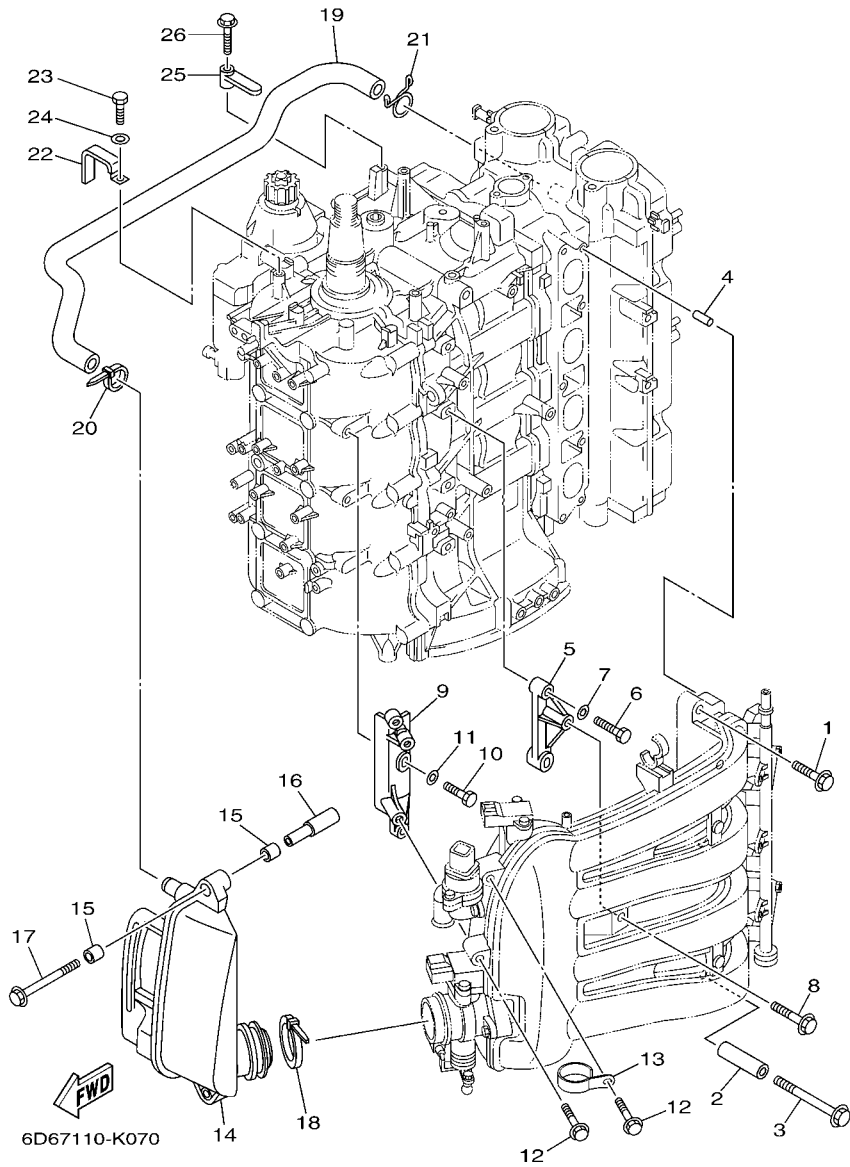
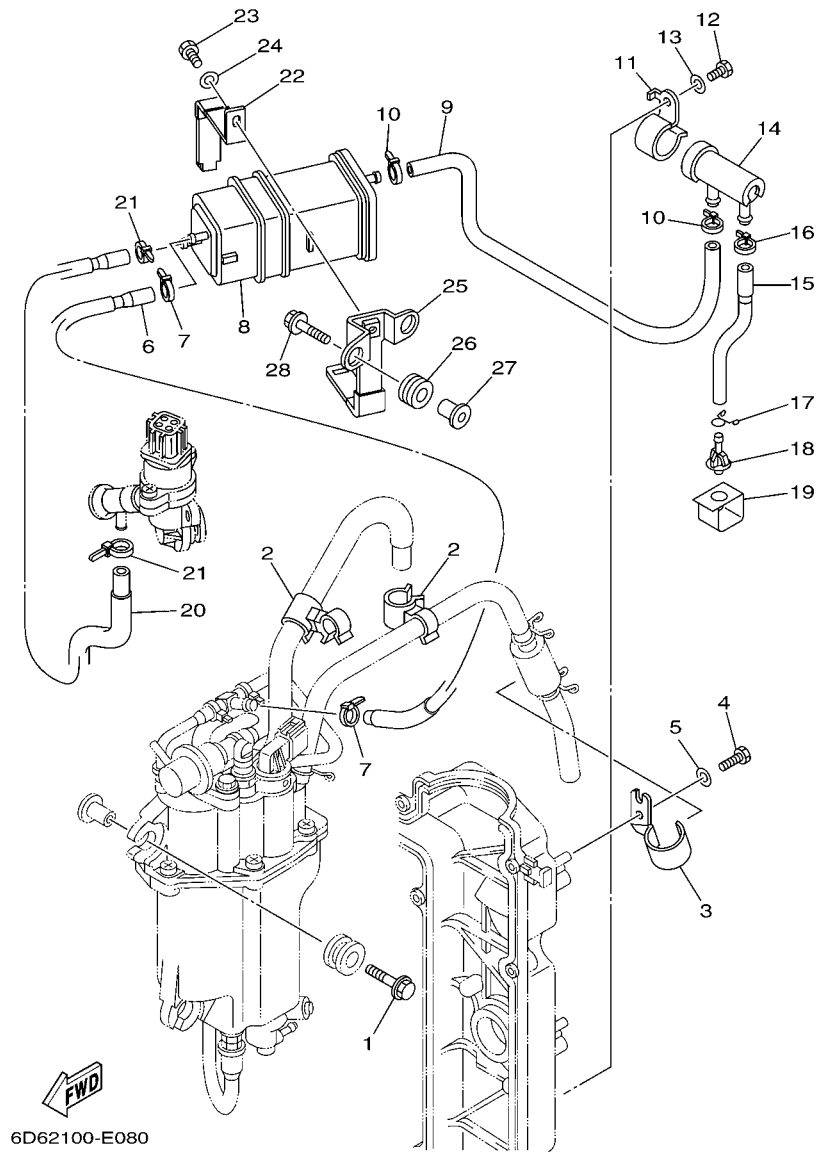

FIG. 7 INTAKE 2

ADMISION 2

REF. NO.	PART NO. CODIGO Nº	DESCRIPTION DESCRIPCION	6D66	6D76	6D86	6D96	REMARKS OBSERVACIONES
26	95895-06025	BOLT, FLANGE TORNILLO DE REBORDE	1	1	1	1	



6D62100-E080

FIG. 8 INTAKE 3

ADMISION 3

REF. NO.	PART NO. CODIGO N°	DESCRIPTION DESCRIPCION	6D66	6D76	6D86	6D96	REMARKS OBSERVACIONES
1	90119-06M08	BOLT, WITH WASHER TORNILLO CON ARANDELA	3	3	3	3	
2	90464-15007	CLAMP BRIDA	2	2	2	2	
3	6D8-13428-01	BRACKET, STRAINER 1 SOPORTE COLADOR 1	1	1	1	1	
4	97095-06012	BOLT PERNO	1	1	1	1	
5	92995-06600	WASHER ARANDELA	1	1	1	1	
6	6D8-24314-01	PIPE 4 TUBO 4	1	1	1	1	
7	90465-11M10	CLAMP BRIDA	2	2	2	2	
8	69J-24170-00	CANISTER ASSY FRANJA DE DEPOSITO DE COMBUST.	1	1	1	1	
9	6D8-24315-00	PIPE 5 TUBO DE DESAGUE	1	1	1	1	
10	90465-11M10	CLAMP BRIDA	2	2	2	2	
11	6D8-2417H-01	CLAMP 1 GRAMPA 1	1	1	1	1	
12	97095-06010	BOLT PERNO	1	1	1	1	
13	92995-06600	WASHER ARANDELA	1	1	1	1	
14	69J-24502-00	FILTER, FUEL FILTRO	1	1	1	1	
15	6D8-24316-00	PIPE 6 TUBO 6	1	1	1	1	
16	90465-11M10	CLAMP BRIDA	1	1	1	1	
17	90467-09M03	CLIP PRESILLA	1	1	1	1	
18	69J-44391-00	NIPPLE, HOSE NIPLE MANGUERA	1	1	1	1	
19	6D8-2413X-01	PLATE PLACA	1	1	1	1	
20	6D8-24317-01	PIPE 7 TUBO 7	1	1	1	1	
21	90465-11M10	CLAMP BRIDA	2	2	2	2	
22	69J-2419A-01	HOLDER SOSTEN	1	1	1	1	
23	97095-06016	BOLT PERNO	1	1	1	1	
24	92995-06600	WASHER ARANDELA	1	1	1	1	
25	6D8-2134X-00	BRACKET, CANISTER SOPORTE	1	1	1	1	
26	90480-10M23	GROMMET TAPON	2	2	2	2	
27	90387-06M60	COLLAR ESPACIADOR	2	2	2	2	

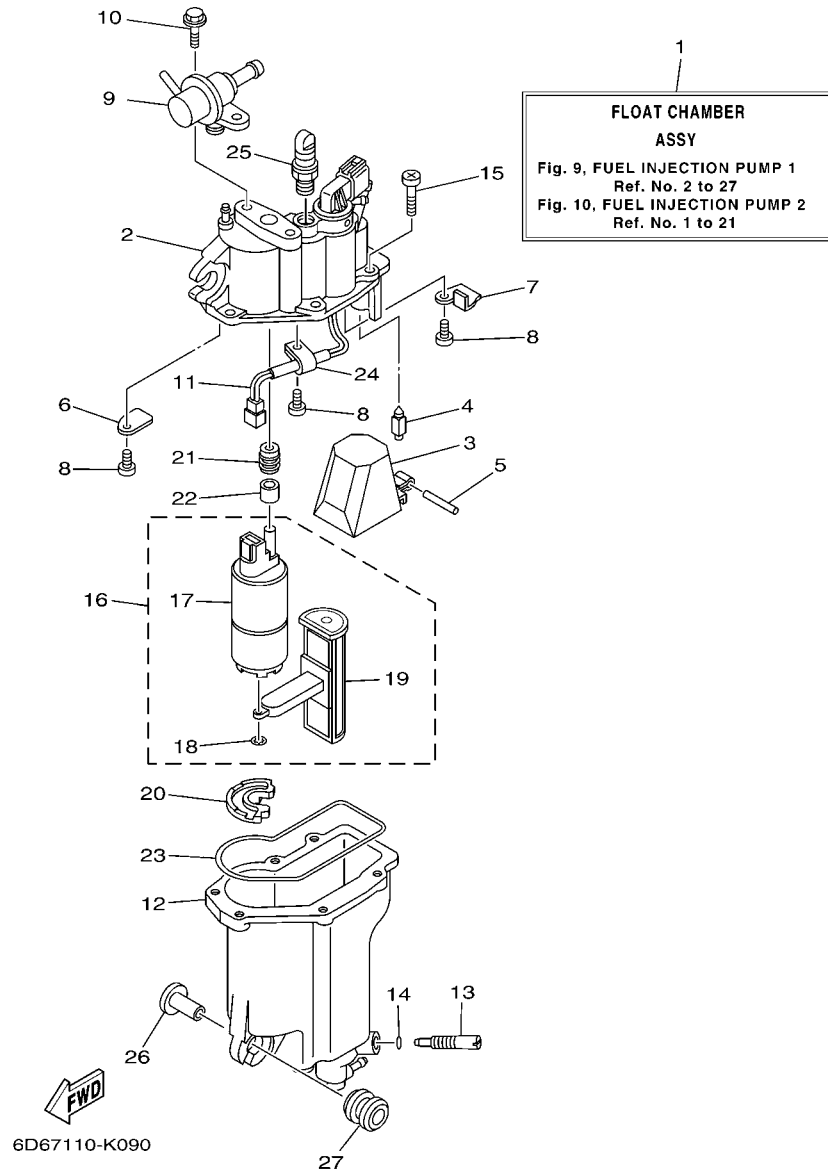
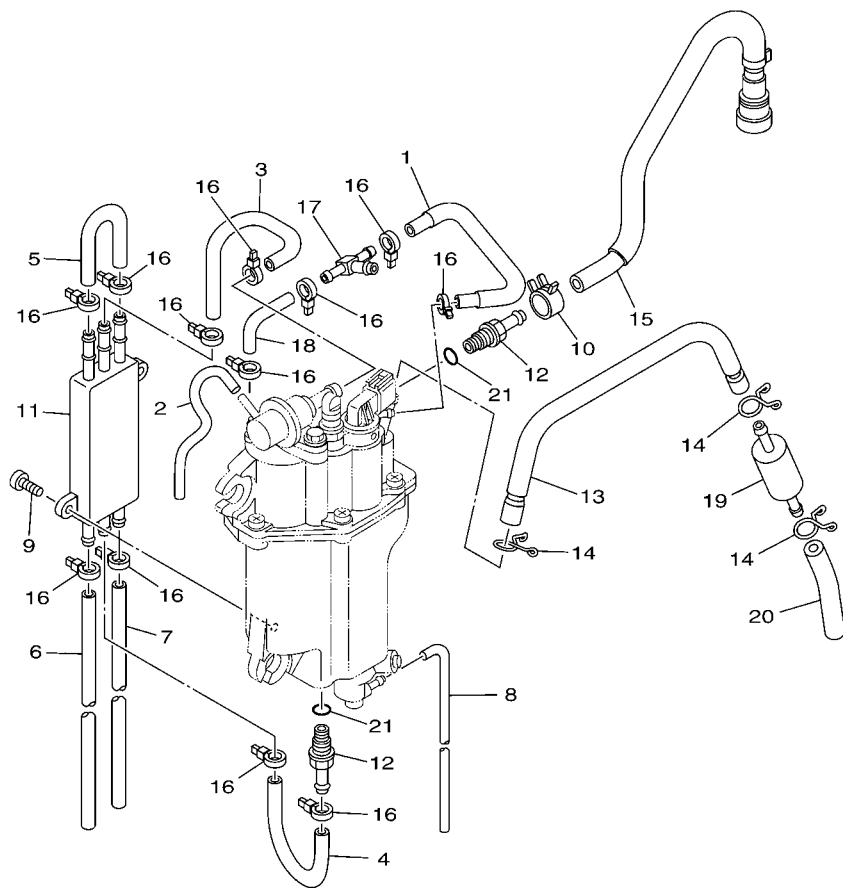

FIG. 9 FUEL INJECTION PUMP 1 BOMBA DE INYECTOR 1

REF. NO.	PART NO. CODIGO Nº	DESCRIPTION DESCRIPCION	6D66	6D76	6D88	6D98	REMARKS OBSERVACIONES
1	6D8-14180-21	FLOAT CHAMBER ASSY CAMARA DE BOIA COMPLETE		1	1	1	FOR CAR(EPA),BRA FOR CAR(EPA),BRA
	6D8-14180-40	FLOAT CHAMBER ASSY CAMARA DE BOIA COMPLETE	1		1		
2	6D8-14182-10	COVER, FLOAT CHAMBER TAPA DE CAMARA DE BOIA	1	1	1	1	
3	6C5-14985-00	FLOAT BOIA	1	1	1	1	
4	6C5-14546-10	VALVE, NEEDLE VALVULA DE AGUJA	1	1	1	1	
5	6C5-14386-00	PIN, FLOAT PASADOR DE BOIA	1	1	1	1	
6	6C5-2441R-10	PLATE, BAFFLE 1 PLACA DEFLECTORA 1	1	1	1	1	
7	6C5-2441T-10	PLATE, BAFFLE 2 PLACA DEFLECTORA 2	1	1	1	1	
8	6C5-24453-00	SCREW TORNILLO	3	3	3	3	
9	6C5-13906-01	REGULATOR, PRESSURE REGULADOR	1	1	1	1	
10	6C5-24592-00	BOLT TORNILLO	2	2	2	2	
11	6C5-87226-00	WIRE HARNESS ASSY CONJUNTO DE CABLES	1	1	1	1	
12	6D8-14960-10	BODY ASSY CAJA COMPL.	1	1	1	1	
13	6C5-14191-00	PLUG, DRAIN TORNILLO, DE DRENAJE	1	1	1	1	
14	6C5-14397-00	O-RING ANILLO O	1	1	1	1	
15	6C5-14567-00	SCREW TORNILLO	6	6	6	6	
16	6C5-13910-10	FUEL PUMP ASSY BOMBA DE COMBUSTIBLE COMPLETE	1	1	1	1	
17	6C5-13907-00	.FUEL PUMP COMP. .BOMBA DE COMBUSTIBLE COMPLETE	1	1	1	1	
18	6C5-14127-10	.CLIP .PRESILLA	1	1	1	1	
19	6C5-13915-00	.FILTER .FILTRO	1	1	1	1	
20	6C5-13593-00	DAMPER COJINETE DE RODILLOS	1	1	1	1	
21	6C5-13781-00	DAMPER, PUMP AMORTIGUADOR DE BOMBA	1	1	1	1	
22	6C5-13716-00	COLLAR COLLAR	1	1	1	1	
23	6C5-14984-00	GASKET, FLOAT CHAMBER EMPAQUE CAMARA DE BOIA	1	1	1	1	
24	6C5-21337-10	CLAMP, CABLE GRAMPA DE CABLE	1	1	1	1	
25	6C5-14225-00	CAP TAPA	1	1	1	1	
26	90387-06M69	COLLAR ESPACIADOR	3	3	3	3	

FIG. 10 FUEL INJECTION PUMP 2

BOMBA DE INYECTOR 2



6D67110-K100

REF. NO.	PART NO. CODIGO Nº	DESCRIPTION DESCRIPCION	6D66	6D76	6D86	6D96	REMARKS OBSERVACIONES
1	6D8-13546-01	HOSE 2 SELLO	1	1	1	1	
2	6D8-13542-01	HOSE, VACUUM SENSING 1 MANGUERA, DE VACIO 1	1	1	1	1	
3	6C5-24321-00	PIPE 10 TUBO 10		1	1	1	
	6C5-24321-20	PIPE 10 TUBO 10	1		1		FOR CAR(EPA),BRA FOR CAR(EPA),BRA
4	6C5-24322-00	PIPE 11 TUBO 11		1	1	1	
	6C5-24322-20	PIPE 11 TUBO 11	1		1		FOR CAR(EPA),BRA FOR CAR(EPA),BRA
5	6C5-24323-00	PIPE 12 TUBO 12	1	1	1	1	
6	6D8-24324-01	PIPE 13 TUBO 13	1	1	1	1	
7	6D8-24325-10	PIPE 14 TUBO 14	1	1	1	1	
8	6BG-14149-00	PIPE TUBO	1	1	1	1	
9	6C5-24444-00	SCREW TORNILLO	2	2	2	2	
10	6C5-13577-00	CLIP PRESILLA	1	1	1	1	
11	6C5-21841-00	COOLER ENFRIADOR	1	1	1	1	
12	6C5-14251-00	NIPPLE NIPLE	2	2	2	2	
13	6D8-14148-00	PIPE TUBO		1	1	1	
	6D8-14148-20	PIPE TUBO	1		1		FOR CAR(EPA),BRA FOR CAR(EPA),BRA
14	6C5-24387-00	CLIP MORDAZA	3	3	3	3	
15	6D8-13974-00	PIPE, FUEL 4 TUBO, COMBUSTIBLE 4	1	1	1	1	
16	90465-11M10	CLAMP BRIDA	12	12	12	12	
17	6C5-24379-00	PIPE, JOINT 4 TUBO DE UNION 4	1	1	1	1	
18	6C5-13545-00	HOSE 1 SELLO	1	1	1	1	
19	6C5-24251-00	STRAINER 1 COLADOR 1	1	1	1	1	
20	6D8-2451B-00	HOSE, FUEL INLET TUBO		1	1	1	
	6D8-2451B-20	HOSE, FUEL INLET TUBO	1		1		FOR CAR(EPA),BRA FOR CAR(EPA),BRA
21	6C5-13739-00	O-RING ANILLO O	2	2	2	2	

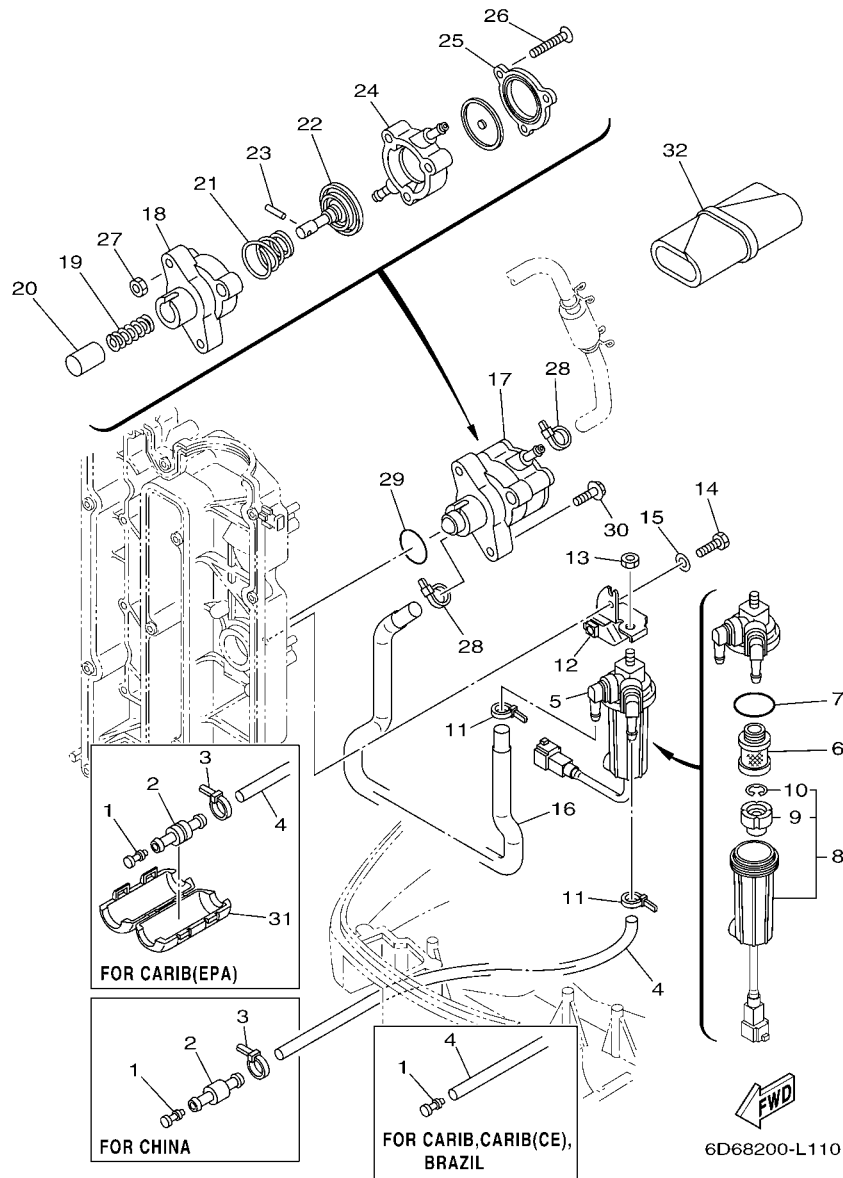

FIG. 11 FUEL 1

COMBUSTIBLE 1

REF. NO.	PART NO. CODIGO Nº	DESCRIPTION DESCRIPCION	6D68	6D78	6D88	6D98	REMARKS OBSERVACIONES
1	689-85547-00	DAMPER AMORTIGUADOR	1	1	1	1	
2	6R3-24377-10	PIPE, JOINT 2 TUBO DE UNION 2	1	1			FOR CAR(EPA) FOR CAR(EPA)
	6R3-24377-00	PIPE, JOINT 2 TUBO DE UNION 2		1			FOR CHN FOR CHN
3	90465-11M10	CLAMP BRIDA	1	1	1		FOR CAR(EPA),CHN FOR CAR(EPA),CHN
4	90445-13M37	HOSE (L2300) TUBO (L2300)		1	1	1	FOR CAR,CAR(CE),BRA FOR CAR,CAR(CE),BRA
	90445-13015	HOSE (L1300) MANGUERA (L1300)	1		1		FOR CAR(EPA) FOR CAR(EPA)
	90445-13M27	HOSE (L950) TUBO (L950)		1			FOR CHN FOR CHN
5	6D8-24560-00	FILTER ASSY FILTRO COMPLETO	1	1	1	1	
6	6D8-24563-00	.ELEMENT, FILTER .ELEMENTO DEL FILTRO	1	1	1	1	
7	6D8-24564-00	.GASKET .EMPAQUE	1	1	1	1	
8	6D8-24562-00	.CUP, FILTER .COPA DE FILTRO	1	1	1	1	
9	6D8-24469-00	..FLOAT, WATER LEVEL ..BOIA	1	1	1	1	
10	6D8-24519-00	..CLIP ..PRESILLA	1	1	1	1	
11	90465-11M10	CLAMP BRIDA	2	2	2	2	
12	6D8-24566-00	BRACKET, FILTER SOPORTE DEL FILTRO	1	1	1	1	
13	95380-08600	NUT TUERCA	1	1	1	1	
14	97095-06016	BOLT PERNO	1	1	1	1	
15	92995-06600	WASHER ARANDELA	1	1	1	1	
16	6D8-24311-00	PIPE, FUEL 1 TUBO DE COMBUSTIBLE 1		1	1	1	EXCEPT CAR(EPA) EXCEPT CAR(EPA)
	6D8-24311-10	PIPE, FUEL 1 TUBO DE COMBUSTIBLE 1	1		1		FOR CAR(EPA) FOR CAR(EPA)
17	6D8-24410-10	FUEL PUMP ASSY BOMBA DE COMBUSTIBLE COMPLETA	1	1	1	1	
18	68V-24412-00	.BODY 1 .CUERPO 1	1	1	1	1	
19	68V-24454-00	.SPRING .RESORTE	1	1	1	1	
20	63P-13131-00	.PLUNGER .ESPACIADOR	1	1	1	1	
21	68V-24423-00	.SPRING, DIAPHRAGM .RESORTE DE DIAFRAGMA	1	1	1	1	
22	68V-24411-00	.DIAPHRAGM .DIAFRAGMA	1	1	1	1	
23	68V-24374-00	.PIN .PASADOR	1	1	1	1	

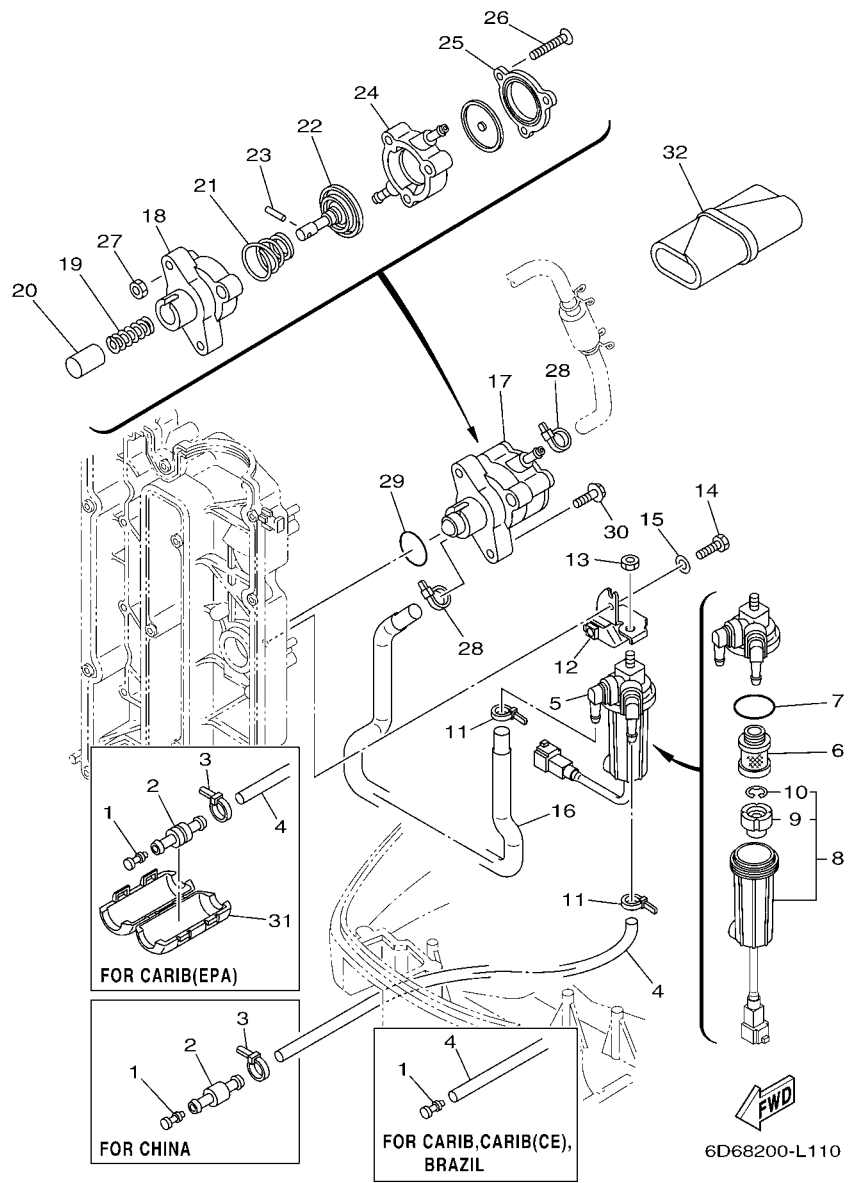
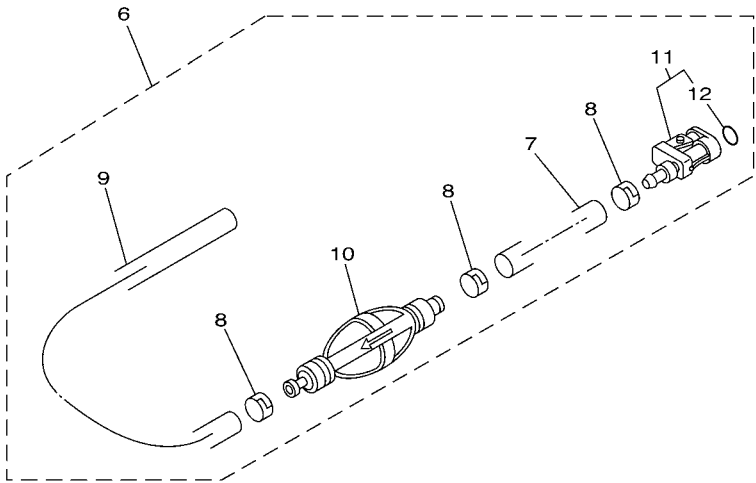
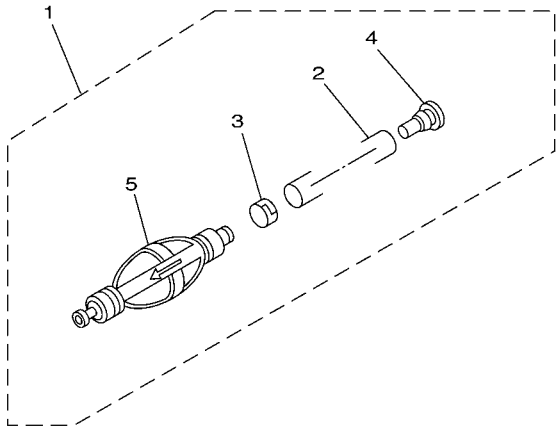

FIG. 11 FUEL 1

COMBUSTIBLE 1

REF. NO.	PART NO. CODIGO Nº	DESCRIPTION DESCRIPCION	6D68	6D78	6D88	6D98	REMARKS OBSERVACIONES
24	68V-24413-10	.BODY 2 .CUERPO 2	1	1	1	1	
25	6D8-24414-00	.BODY 3 .CUERPO 3	1	1	1	1	
26	68V-24444-00	.SCREW .TORNILLO	3	3	3	3	
27	68V-24149-00	.NUT .TUERCA	3	3	3	3	
28	90465-11M10	CLAMP BRIDA	2	2	2	2	
29	93210-30682	O-RING ANILLO O	1	1	1	1	
30	90119-06M83	BOLT, WITH WASHER TORNILLO CON ARANDELA	2	2	2	2	
31	68V-24452-00	COVER CUBIERTA	1		1		FOR CAR(EPA) FOR CAR(EPA)
32	67F-28100-01	TOOL KIT JUEGO DE HERRAMIENTAS	1	1	1	1	UR UR
	67F-28100-10	TOOL KIT JUEGO DE HERRAMIENTAS	1	1	1	1	UR UR



64D3100-C100

FIG. 12 FUEL 2

COMBUSTIBLE 2

REF. NO.	PART NO. CODIGO Nº	DESCRIPTION DESCRIPCION	6D66	6D78	6D88	6D98	REMARKS OBSERVACIONES
1	6Y2-24307-50	FUEL PIPE COMP. 2 .MANGUERA COMPL,COMBUSTIBLE 2			1		AP FOR CAR,BRA AP FOR CAR,BRA
2	90445-13M01	.HOSE (L2050) .MANGUERA (L2050)			1		
3	6E5-24351-51	.BAND 1 .ABRAZADERA 1			1		
4	90480-06M19	.GROMMET .TAPON			1		
5	6Y2-24360-60	.PRIMER PUMP ASSY .SOPORTE BOMBA			1		
6	6Y2-24306-45	FUEL PIPE COMP. 1 TUBO COMBUST. COMPL 1				1	AP FOR CAR(CE) AP FOR CAR(CE)
7	90445-13M01	.HOSE (L2050) .MANGUERA (L2050)				1	
8	6E5-24351-51	.BAND 1 .ABRAZADERA 1				3	
9	90445-13M35	.HOSE (L250) .MANGUERA (L250)				1	
10	6Y2-24360-60	.PRIMER PUMP ASSY .SOPORTE BOMBA				1	
11	6Y2-24305-06	.FUEL PIPE JOINT COMP. 2 .CONECTOR MANGUERA COMBUST. 2				1	
12	93210-08287	..O-RING ..ANILLO O				1	

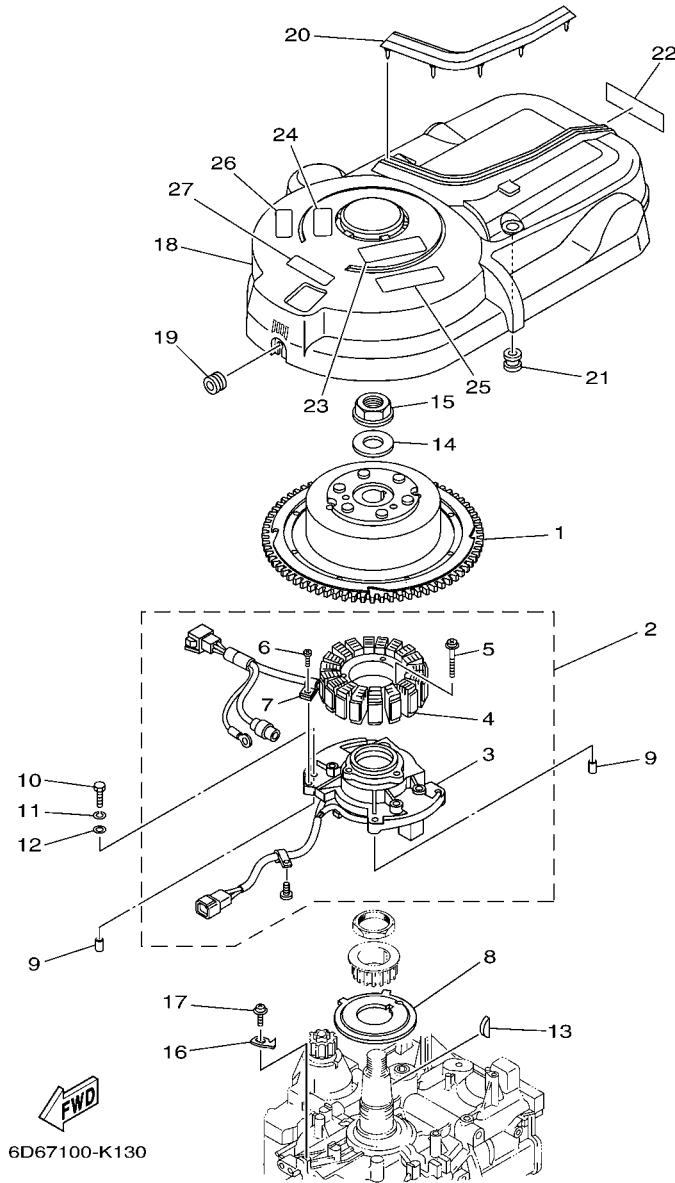

FIG. 13 GENERATOR

GENERADOR

REF. NO.	PART NO. CODIGO Nº	DESCRIPTION DESCRIPCION	6D66	6D76	6D86	6D96	REMARKS OBSERVACIONES
1	6D8-81450-00	ROTOR ASSY ROTOR COMPLETO	1	1	1	1	
2	6D8-81460-00	BASE ASSY CONJUNTO BASE	1	1	1	1	
3	6D8-85580-00	.COIL, PULSER .BOBINA DE PULSACION	1	1	1	1	
4	6D8-81410-00	.STATOR ASSY .ESTATOR COMPLETO	1	1	1	1	
5	63D-81345-20	.SCREW, WITH WASHER (M6X30) .TORNILLO, CON ARANDELA (M6X30)	3	3	3	3	
6	97607-04110	.SCREW, WITH WASHER .TORNILLO CAB CON PLANA C/ARAN	1	1	1	1	
7	445-81328-20	.CLAMP .GRAMPA	1	1	1	1	
8	68V-81673-00	ROTOR ROTOR	1	1	1	1	
9	99530-08012	PIN, DOWEL PASADOR, DE ESPIGA	2	2	2	2	
10	97095-06030	BOLT PERNO	4	4	4	4	
11	92995-06100	WASHER, SPRING ARANDELA	4	4	4	4	
12	92995-06600	WASHER ARANDELA	4	4	4	4	
13	90280-05015	KEY, WOODRUFF CUNA WOODRUFF	1	1	1	1	
14	90201-24014	WASHER, PLATE ARANDELA PLANA	1	1	1	1	
15	90179-24002	NUT TUERCA	1	1	1	1	
16	6D8-81332-00	PLATE, TIMING PLACA REGULADOR DE TIEMPO	1	1	1	1	
17	97985-06210	SCREW, WITH WASHER TORNILLO, CON ARANDELA	1	1	1	1	
18	6D8-81337-00	COVER, FLYWHEEL CUBIERTA DE VOLANTE	1	1	1	1	
19	90480-12314	GROMMET TAPON	1	1	1	1	
20	6D8-85547-00	DAMPER AMORTIGUADOR	1	1	1	1	
21	663-82317-01	DAMPÉR, IGNITION COIL AMORTIGUADOR BOBINA ENCENDIDO	2	2	2	2	
22	68V-13437-42	MARK, CAUTION MARKER		1			FOR CHN FOR CHN
	68V-13437-62	MARK, CAUTION MARKER	1	1	1	1	FOR CAR FOR CAR
23	6AH-81995-40	LABEL, WARNING ETIQUETA DE PRECAUCION	1	1	1	1	EXCEPT FOR BRA EXCEPT FOR BRA
	6AH-81995-70	LABEL, WARNING ETIQUETA DE PRECAUCION			1		FOR BRA FOR BRA
24	6AH-81995-50	LABEL, WARNING ETIQUETA DE PRECAUCION	1	1	1	1	FOR CAR FOR CAR
25	6AH-81994-40	LABEL, SAFETY ETIQUETA DE SEGURIDAD	1	1	1	1	EXCEPT FOR BRA EXCEPT FOR BRA

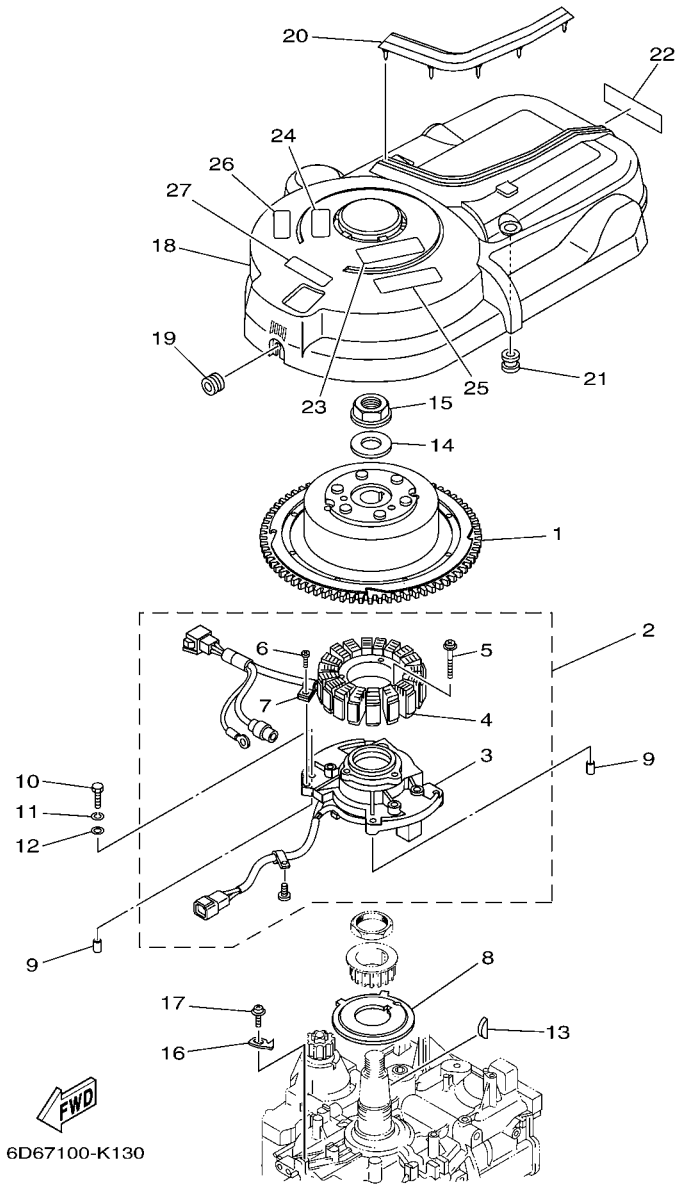

FIG. 13 GENERATOR

GENERADOR

REF. NO.	PART NO. CODIGO Nº	DESCRIPTION DESCRIPCION	6D66	6D78	6D88	6D98	REMARKS OBSERVACIONES
25	6AH-81994-70	LABEL, SAFETY ETIQUETA DE SEGURIDAD			1		FOR BRA FOR BRA
26	6AH-81994-50	LABEL, SAFETY ETIQUETA DE SEGURIDAD	1	1	1	1	FOR CAR FOR CAR
27	6AG-81996-00	MARK MARCA	1	1	1	1	

FIG. 14 ELECTRICAL 1

EQUIPO ELECTRICO 1

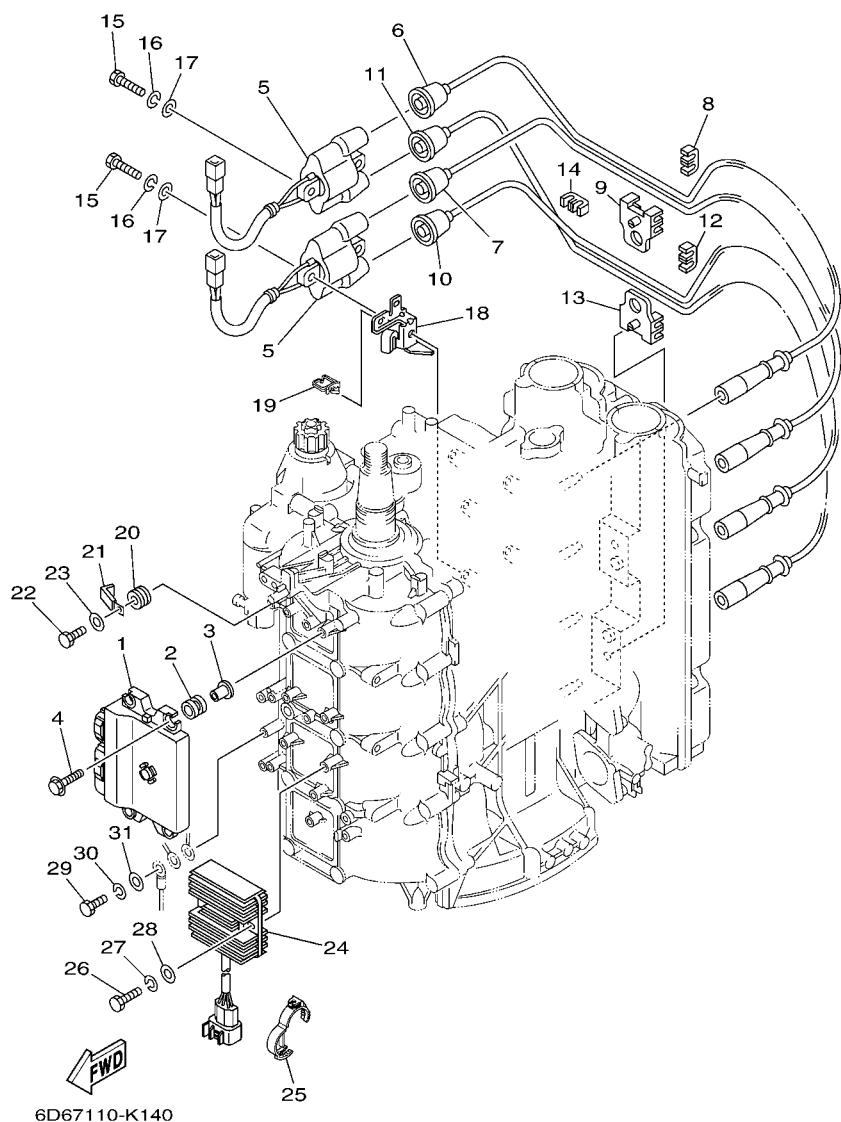

REF. NO.	PART NO. CODIGO Nº	DESCRIPTION DESCRIPCION	6D66	6D76	6D86	6D96	REMARKS OBSERVACIONES
1	6D6-8591A-13	ENGINE CONTROL UNIT ASSY UNIDAD CONTROL	1	1			FOR CAR(EPA),CHN
	6D7-8591A-13	ENGINE CONTROL UNIT ASSY UNIDAD CONTROL			1		FOR CAR(EPA),CHN
	6D8-8591A-13	ENGINE CONTROL UNIT ASSY UNIDAD CONTROL				1	FOR CAR(CE)
	6D8-8591A-23	ENGINE CONTROL UNIT ASSY UNIDAD CONTROL				1	FOR CAR,CAR(EPA)
	6D9-8591A-13	ENGINE CONTROL UNIT ASSY UNIDAD CONTROL				1	FOR CAR,CAR(EPA)
							FOR BRA
2	68V-82317-00	DAMPER, IGNITION COIL AMORTIGUADOR BOBINA ENCENDIDO	4	4	4	4	
3	90387-06119	COLLAR ESPACIADOR	4	4	4	4	
4	90119-06M59	BOLT, WITH WASHER TORNILLO CON ARANDELA	4	4	4	4	
5	63P-82310-01	IGNITION COIL ASSY BOBINA DE ENCENDIDO COMPLETA	2	2	2	2	
6	67F-82341-00	CORD, HIGH TENSION 1 CABLE DE ALTA TENSION 1	1	1	1	1	#1
7	67F-82342-00	CORD, HIGH TENSION 2 CABLE DE ALTA TENSION 2	1	1	1	1	#1
							#2
8	67F-82361-00	CLAMP, CORD GRAMPA DE CABLE	1	1	1	1	
9	67F-82362-00	CLAMP, CORD 2 GRAMPA DE CABLE 2	1	1	1	1	
10	67F-82343-00	CORD, HIGH TENSION 3 CABLE DE ALTA TENSION 3	1	1	1	1	#3
11	67F-82344-00	CORD, HIGH TENSION 4 CABLE DE ALTA TENSION 4	1	1	1	1	#3
							#4
12	67F-82361-00	CLAMP, CORD GRAMPA DE CABLE	1	1	1	1	
13	67F-82362-00	CLAMP, CORD 2 GRAMPA DE CABLE 2	1	1	1	1	
14	67F-82361-00	CLAMP, CORD GRAMPA DE CABLE	1	1	1	1	
15	97095-06025	BOLT PERNO	4	4	4	4	
16	92995-06100	WASHER, SPRING ARANDELA	4	4	4	4	
17	92995-06600	WASHER ARANDELA	4	4	4	4	
18	6D8-82388-01	PLATE PLACA	2	2	2	2	
19	90464-08004	CLAMP BRIDA	2	2	2	2	
20	90480-14329	GROMMET TAPON	1	1	1	1	
21	90465-08M23	CLAMP BRIDA	1	1	1	1	
22	97095-06014	BOLT PERNO	1	1	1	1	
23	92995-06600	WASHER ARANDELA	1	1	1	1	

FIG. 14 ELECTRICAL 1

EQUIPO ELECTRICO 1

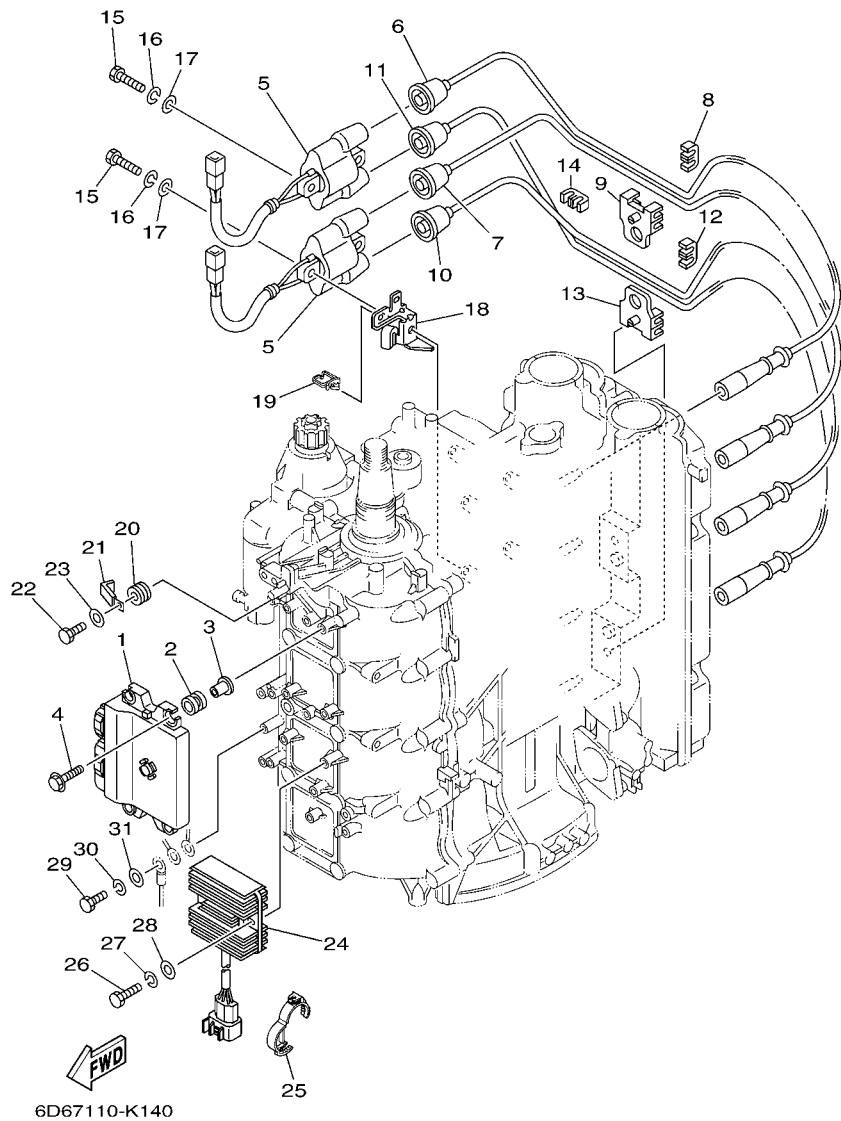

REF. NO.	PART NO. CODIGO Nº	DESCRIPTION DESCRIPCION	6D66	6D76	6D86	6D96	REMARKS OBSERVACIONES
24	6D8-81960-10	RECTIFIER & REGULATOR ASSY RECTIFICADOR Y REGULADOR	1	1	1	1	
25	90464-30003	CLAMP BRIDA	1	1	1	1	
26	97095-06025	BOLT PERNO	2	2	2	2	
27	92995-06100	WASHER, SPRING ARANDELA	2	2	2	2	
28	92995-06600	WASHER ARANDELA	2	2	2	2	
29	97095-06016	BOLT PERNO	1	1	1	1	
30	92995-06100	WASHER, SPRING ARANDELA	1	1	1	1	
31	92995-06600	WASHER ARANDELA	1	1	1	1	

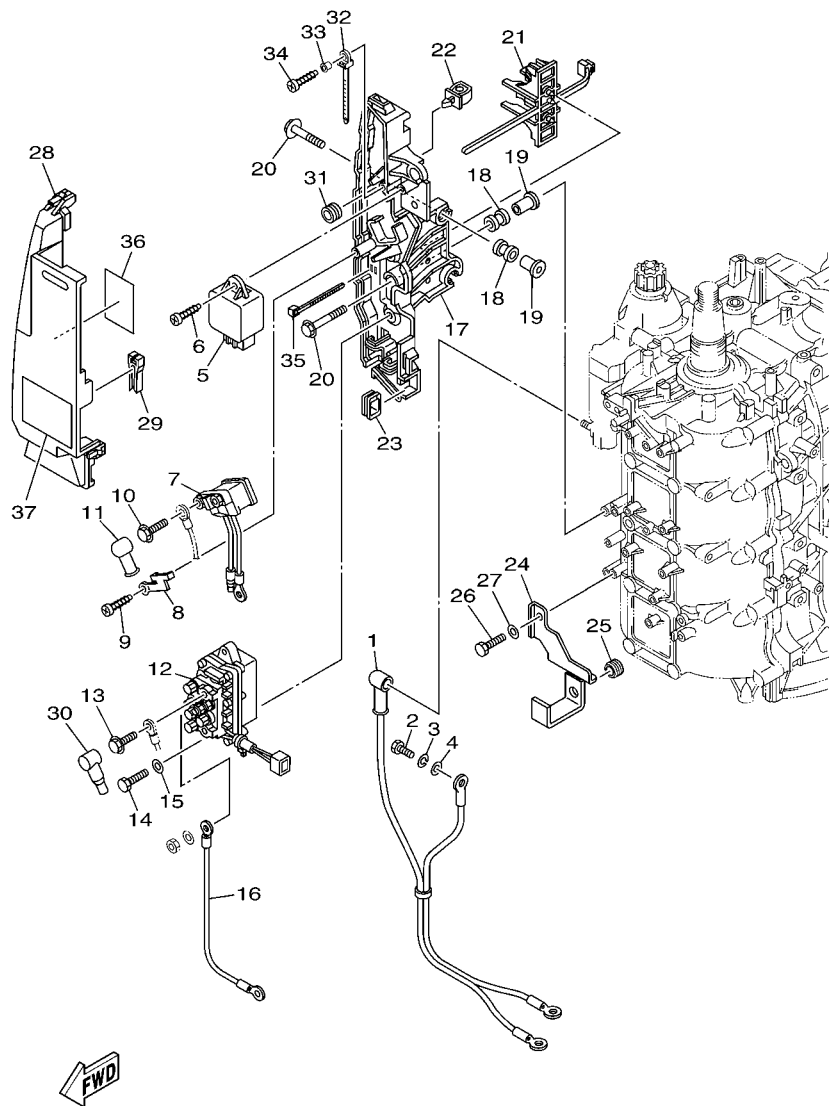

6D77300-K150

FIG. 15 ELECTRICAL 2

EQUIPO ELECTRICO 2

REF. NO.	PART NO. CODIGO Nº	DESCRIPTION DESCRIPCION	6D66	6D76	6D86	6D96	REMARKS OBSERVACIONES
1	68V-82105-00	WIRE HARNESS ARNES DE CABLES	1	1	1	1	
2	97013-06020	BOLT PERNO	1	1	1	1	
3	92903-06100	WASHER, SPRING RONDANA SENCILLA	1	1	1	1	
4	92903-06600	WASHER, PLATE RONDANA SENCILLA	1	1	1	1	
5	60E-81950-00	RELAY ASSY RELE COMPLETO	1	1	1	1	
6	97780-60625	SCREW, TAPPING TORNILLO DE CABEZA DE CONO ACH	1	1	1	1	
7	68V-8194A-00	RELAY RELE	1	1	1	1	
8	68V-81953-00	STAY, RELAY SOPORTE DE RELE	1	1	1	1	
9	97780-60620	SCREW, TAPPING TORNILLO DE CABEZA DE CONO ACH	1	1	1	1	
10	97595-06610	BOLT, WITH WASHER PERNO CON ARANDELA	2	2	2	2	
11	6G5-82119-00	COVER, LEAD WIRE CUBIERTA DE CABLE CONDUCTOR	2	2	2	2	
12	63P-81950-00	RELAY ASSY RELE COMPLETO	1	1	1	1	
13	97595-06610	BOLT, WITH WASHER PERNO CON ARANDELA	2	2	2	2	
14	97013-06020	BOLT PERNO	2	2	2	2	
15	92903-06600	WASHER, PLATE RONDANA SENCILLA	2	2	2	2	
16	61A-81949-00	WIRE, LEAD CABLE CONDUCTOR	1	1	1	1	
17	68V-81948-02	BRACKET SOPORTE	1	1	1	1	
18	6A0-82317-00	DAMPER, IGNITION COIL AMORTIGUADOR BOBINA ENCENDIDO	5	5	5	5	
19	90387-06119	COLLAR ESPACIADOR	5	5	5	5	
20	90119-06M59	BOLT, WITH WASHER TORNILLO CON ARANDELA	5	5	5	5	
21	68V-82594-00	CLAMP GRAMPA	1	1	1	1	
22	90464-12M58	CLAMP BRIDA	1	1	1	1	
23	6D8-81518-00	GROMMET ANILLO PROTECTOR	1	1	1	1	
24	6D8-81528-02	CLAMP 1 GRAMPA 1	1	1	1	1	
25	90480-13M24	GROMMET TAPON	1	1	1	1	
26	97095-06014	BOLT PERNO	1	1	1	1	
27	92995-06600	WASHER ARANDELA	1	1	1	1	

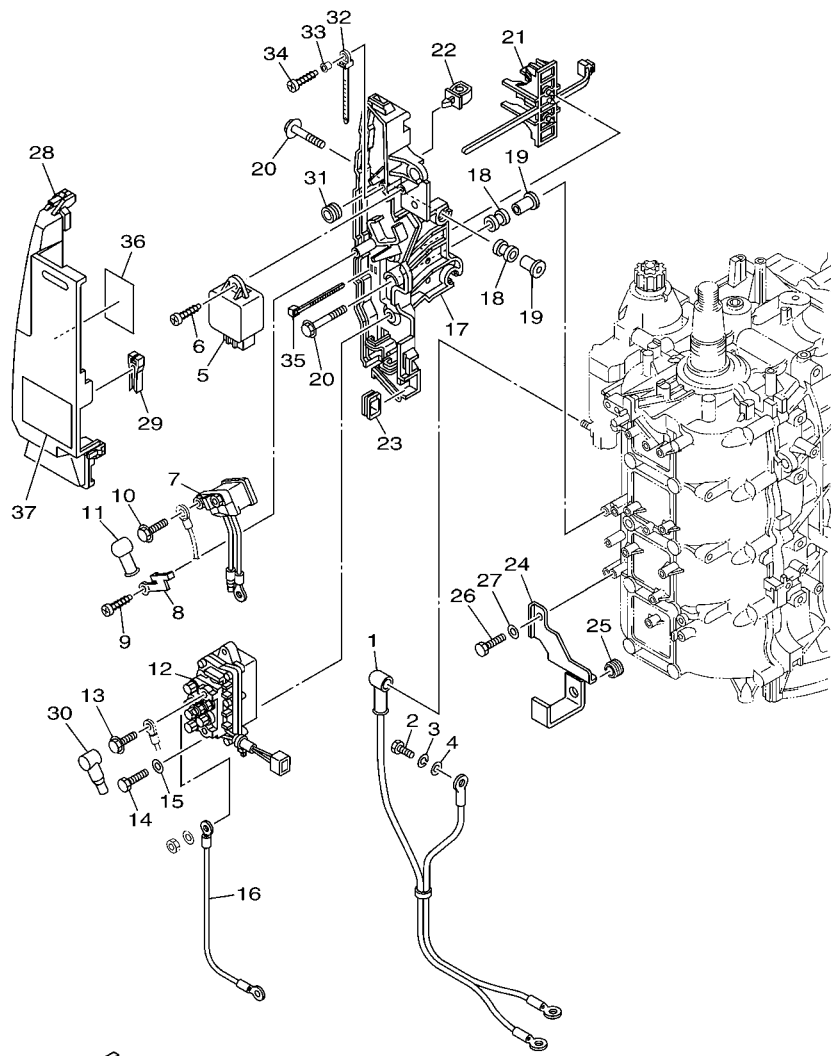

FWD
6D77300-K150

FIG. 15 ELECTRICAL 2

EQUIPO ELECTRICO 2

REF. NO.	PART NO. CODIGO Nº	DESCRIPTION DESCRIPCION	6D66	6D76	6D86	6D96	REMARKS OBSERVACIONES
28	68V-81942-03	COVER CUBIERTA	1	1	1	1	
29	67F-2812A-00	PULLER, FUSE TIRADOR DE FUSIBLE	1	1	1	1	
30	682-82119-01	COVER, LEAD WIRE CUBIERTA DE CABLE CONDUCTOR	2	2	2	2	
31	6A0-82317-00	DAMPER, IGNITION COIL AMORTIGUADOR BOBINA ENCENDIDO	1	1	1	1	
32	90465-12M53	CLAMP BRIDA	1	1	1	1	
33	90387-06M05	COLLAR ESPACIADOR	1	1	1	1	
34	97780-60625	SCREW, TAPPING TORNILLO DE CABEZA DE CONO ACH	1	1	1	1	
35	90465-13M18	CLAMP BRIDA	2	2	2	2	
36	6D8-81919-00	GRAPHIC, REGULATOR CALCAMONIA DE REGULADOR	1	1	1	1	
37	6D8-81919-10	GRAPHIC, REGULATOR CALCAMONIA DE REGULADOR	1	1	1	1	

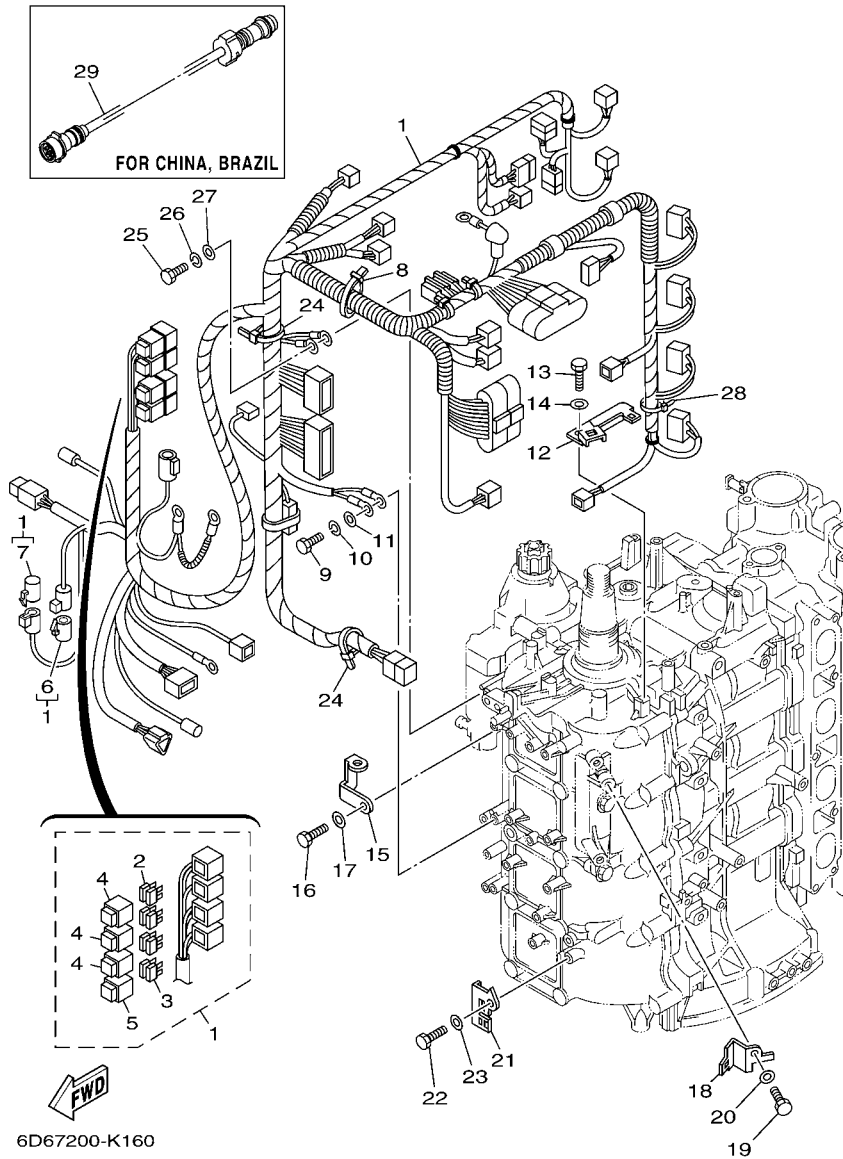

FIG. 16 ELECTRICAL 3

EQUIPO ELECTRICO 3

REF. NO.	PART NO. CODIGO Nº	DESCRIPTION DESCRIPCION	6D66	6D76	6D86	6D96	REMARKS OBSERVACIONES
1	6D8-82590-30	WIRE HARNESS ASSY CONJUNTO DE CABLES	1	1	1	1	
2	67F-82151-00	.FUSE (20A) .FUSIBLE (20A)	6	6	6	6	
3	67F-82151-10	.FUSE (30A) .FUSIBLE (30A)	2	2	2	2	
4	67F-8215B-10	.CAP (YELLOW) .TAPA (AMARILLO)	3	3	3	3	
5	67F-8215B-20	.CAP (GREEN) .TAPA (GREEN)	1	1	1	1	
6	6P2-82582-00	.CAP 1 (FEMALE) .TAPA 1	1	1	1	1	
7	6P2-82582-10	.CAP 1 (MALE) .TAPA 1	1	1	1	1	
8	90464-76001	CLAMP BRIDA	1	1	1	1	
9	97095-06016	BOLT PERNO	1	1	1	1	
10	92995-06100	WASHER, SPRING ARANDELA	1	1	1	1	
11	92995-06600	WASHER ARANDELA	1	1	1	1	
12	6D8-82588-01	PLATE PLACA	1	1	1	1	
13	97095-06012	BOLT PERNO	1	1	1	1	
14	92995-06600	WASHER ARANDELA	1	1	1	1	
15	6D8-82581-01	STAY, CORD CLAMP SOPORTE DE GRAMPA DE CABLE	1	1	1	1	
16	97095-06014	BOLT PERNO	1	1	1	1	
17	92995-06600	WASHER ARANDELA	1	1	1	1	
18	6D8-82389-01	PLATE 2 PLACA 2	1	1	1	1	
19	97095-06012	BOLT PERNO	1	1	1	1	
20	92995-06600	WASHER ARANDELA	1	1	1	1	
21	6D8-82398-01	PLATE 3 PLACA 3	1	1	1	1	
22	97095-06012	BOLT PERNO	1	1	1	1	
23	92995-06600	WASHER ARANDELA	1	1	1	1	
24	90465-13M18	CLAMP BRIDA	2	2	2	2	
25	97095-06016	BOLT PERNO	1	1	1	1	
26	92995-06100	WASHER, SPRING ARANDELA	1	1	1	1	
27	92995-06600	WASHER ARANDELA	1	1	1	1	

FIG. 17 ELECTRICAL 4

EQUIPO ELECTRICO 4

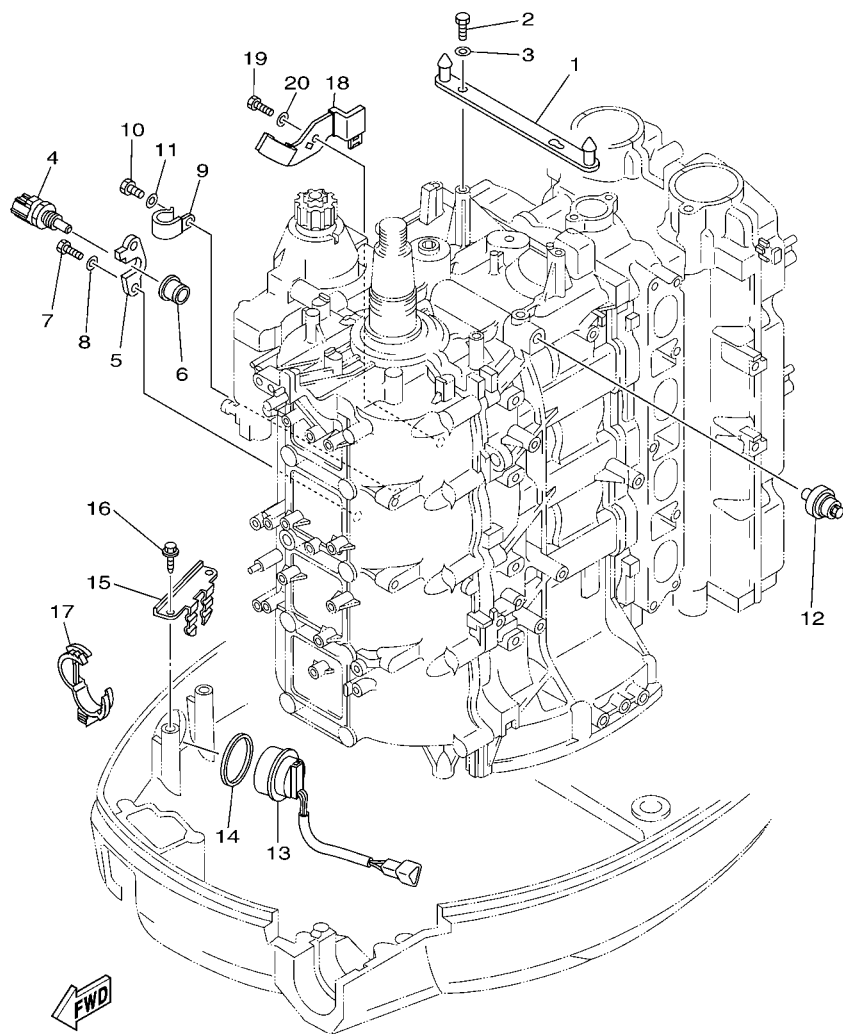

6D65110-H170

REF. NO.	PART NO. CODIGO Nº	DESCRIPTION DESCRIPCION	6D66	6D76	6D86	6D96	REMARKS OBSERVACIONES
1	6D8-8132G-00	PLATE PLACA	1	1	1	1	
2	97095-06016	BOLT PERNO	2	2	2	2	
3	92995-06600	WASHER ARANDELA	2	2	2	2	
4	67F-85790-00	THERMOSENSOR ASSY TERMICA SENSORIO	1	1	1	1	
5	67F-85757-00	RETAINER SEGURO	1	1	1	1	
6	68V-85753-00	GASKET, SENDER UNIT EMPAQUE DE UNIDAD TRANSMISORA	1	1	1	1	
7	97095-06016	BOLT PERNO	2	2	2	2	
8	92995-06600	WASHER ARANDELA	2	2	2	2	
9	90465-06M86	CLAMP BRIDA	1	1	1	1	
10	97095-06012	BOLT PERNO	1	1	1	1	
11	92995-06600	WASHER ARANDELA	1	1	1	1	
12	68V-82504-00	OIL PRESSURE SWITCH ASSY INTERRUPTOR PRESION DE ACEITE	1	1	1	1	
13	63D-82563-10	TRIM & TILT SWITCH ASSY INTERRUPTOR DE INCLINACION	1	1	1	1	
14	6E5-82587-00	GASKET EMPAQUETADURA	1	1	1	1	
15	67F-83614-00	BRACKET SOPORTE	1	1	1	1	
16	90109-06M86	BOLT PERNO	2	2	2	2	
17	90464-30003	CLAMP BRIDA	2	2	2	2	
18	6D8-8252H-01	PLATE, HOLDER PLACA DE SOPORTE	1	1	1	1	
19	97095-06012	BOLT PERNO	1	1	1	1	
20	92995-06600	WASHER ARANDELA	1	1	1	1	

FIG. 18 STARTING MOTOR

MOTOR DE ARRANQUE

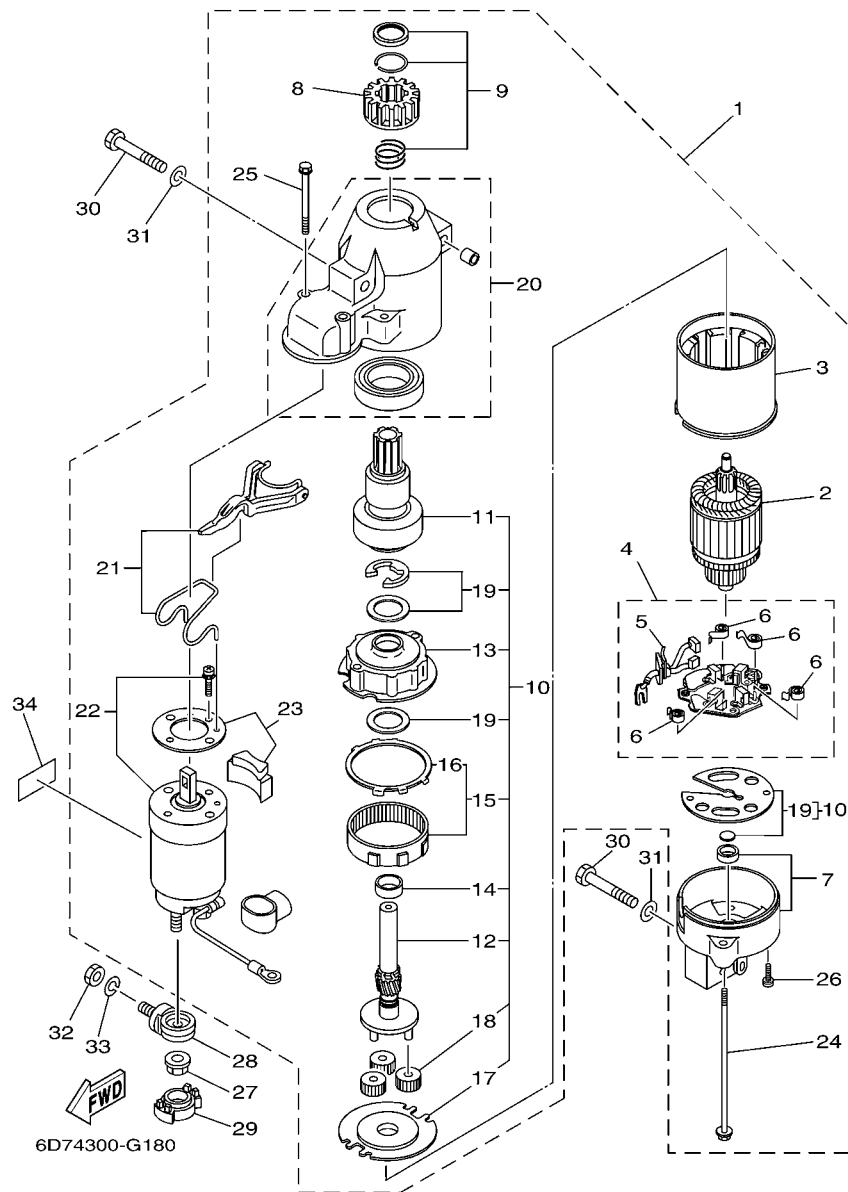

REF. NO.	PART NO. CODIGO Nº	DESCRIPTION DESCRIPCION	6D66	6D76	6D86	6D96	REMARKS OBSERVACIONES
1	68V-81800-01	STARTING MOTOR ASSY MOTOR DE ARRANQUE COMPLETO	1	1	1	1	
2	67F-81850-00	..ARMATURE ASSY ..INDUCIDO COMPLETO	1	1	1	1	
3	67F-81810-00	..STATOR ASSY ..ESTATOR COMPLETO	1	1	1	1	
4	68F-81840-00	..BRUSH HOLDER ASSY ..SOSTEN DE ESCOBILLA COMPLETO	1	1	1	1	
5	67F-81801-00	..BRUSH SET ..JUEGO DE ESCOBILLA	1	1	1	1	
6	67F-81813-00	..SPRING, BRUSH ..RESORTE DE ESCOBILLA	4	4	4	4	
7	68F-81820-00	..REAR BRACKET ASSY ..CUBIERTA TRASERA COMPL	1	1	1	1	
8	67F-81808-00	..PINION ASSY ..PINON	1	1	1	1	
9	67F-81857-00	..PINION STOPPER SET ..JUEGO TAPON PINON	1	1	1	1	
10	67F-81807-00	..GEAR ASSY, STARTING MOTOR ..PINON CONJUNTO	1	1	1	1	
11	67F-81832-00	..CLUTCH, OVER RUN ..PINON COMPL	1	1	1	1	
12	67F-81836-00	..SHAFT, PINION ..ARBOL, PINON	1	1	1	1	
13	67F-81821-00	..BRACKET, CENTER 1 ..SOPORTE, CENTRO 1	1	1	1	1	
14	67F-81841-00	..BEARING ..PORTADOR	1	1	1	1	
15	67F-81891-00	..GEAR, RING ..ENGRANAJE ANILLO	1	1	1	1	
16	67F-8183R-00	..GASKET ..EMPAQUETADURA	1	1	1	1	
17	67F-81830-00	..BRACKET, CENTER 2 ..SOPORTE, CENTRO 2	1	1	1	1	
18	60V-8183T-00	..GEAR, IDLER ..ENGRENAJE NEUTRO	3	3	3	3	
19	67F-81809-00	..WASHER KIT ..JUEGO DE ARANDELA	1	1	1	1	
20	67F-81842-00	..COVER ..TAPA	1	1	1	1	
21	67F-81839-00	..LEVER ASSY ..PALANCA COMPL.	1	1	1	1	
22	68V-81941-01	..STARTER RELAY ASSY ..RELE DE ARRANQUE	1	1	1	1	
23	67F-81869-00	..COVER, DUST ..CUBIERTA PARA POLVO	1	1	1	1	
24	6K7-81826-11	..BOLT ..PERNO	2	2	2	2	
25	67F-81828-00	..SCREW 2 ..TORNILLO DE EMPUJE 2	2	2	2	2	
26	67F-81846-00	..SCREW ..TORNILLO	2	2	2	2	
27	90179-08003	NUT TUERCA	1	1	1	1	

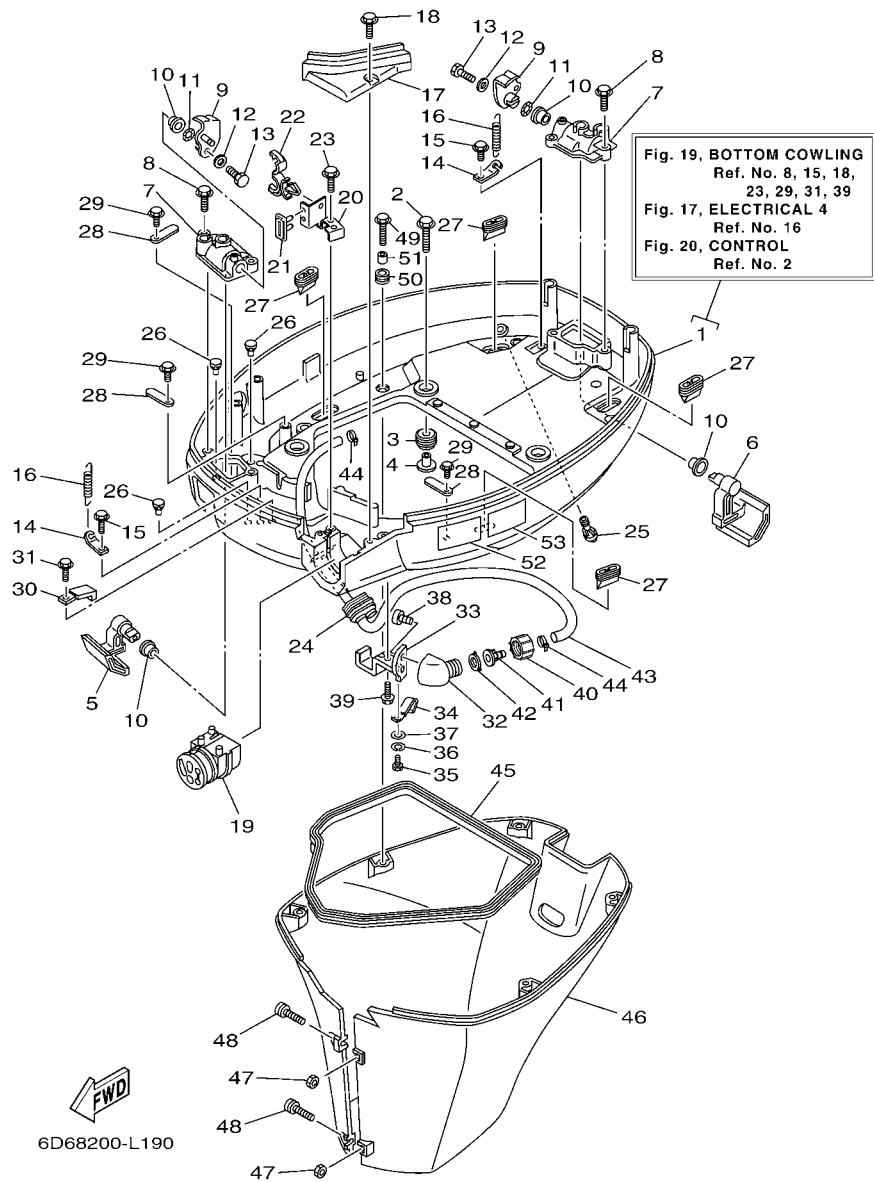

FIG. 19 BOTTOM COWLING

CUBIERTA INFERIOR

REF. NO.	PART NO. CODIGO Nº	DESCRIPTION DESCRIPCION	6D68	6D78	6D88	6D98	REMARKS OBSERVACIONES
1	6D8-42710-00-8D	BOTTOM COWLING ASSY CUBIERTA INFERIOR COMPL.	1	1	1	1	
2	90119-08M22	BOLT, WITH WASHER TORNILLO CON ARANDELA	4	4	4	4	
3	90480-22M15	GROMMET TAPON	4	4	4	4	
4	90387-08M37	COLLAR ESPACIADOR	4	4	4	4	
5	67F-42815-00-8D	LEVER, CLAMP PALANCA ABRAZADERA	1	1	1	1	
6	67F-42816-00-8D	LEVER, CLAMP PALANCA ABRAZADERA	1	1	1	1	
7	67F-42828-00-8D	PLATE, CLAMP PLACA, GRAMPA	2	2	2	2	
8	90109-06M82	BOLT PERNO	4	4	4	4	
9	68V-42818-01	LEVER, CLAMP PALANCA, ABRAZADERA	2	2	2	2	
10	90386-15M73	BUSH BUJE	4	4	4	4	
11	90206-15M18	WASHER, WAVE ARANDELA ONDULADA	2	2	2	2	
12	90201-06068	WASHER, PLATE ARANDELA PLANA	2	2	2	2	
13	97095-06016	BOLT PERNO	2	2	2	2	
14	64D-43144-00	HOOK, SPRING GANCHO	2	2	2	2	
15	90109-06M86	BOLT PERNO	2	2	2	2	
16	90506-16M34	SPRING, TENSION RESORTE DE TENSION	2	2	2	2	
17	67F-42738-00-8D	PLATE, FITTING PLACA DE AJUSTE	1	1	1	1	
18	90109-06M96	BOLT PERNO	2	2	2	2	
19	68V-42725-00	GROMMET TAPON	1	1	1	1	
20	6D8-42756-02	STAY, CLAMP SOPORTE DE GRAMPA	1	1	1	1	
21	6D8-42717-00	RUBBER, SEAL 2 GOMA	1	1	1	1	
22	90464-18246	CLAMP BRIDA	1	1	1	1	
23	90109-06M86	BOLT PERNO	1	1	1	1	
24	6H1-42726-21	GROMMET TAPON	1	1	1	1	FLUSHING KIT FLUSHING KIT
25	6BL-44391-00	NIPPLE, HOSE NIPLE MANGUERA	1	1	1	1	
26	6H4-42748-00	GROMMET TAPON	3	3	3	3	
27	67F-42717-00	RUBBER, SEAL 2 GOMA	4	4	4	4	

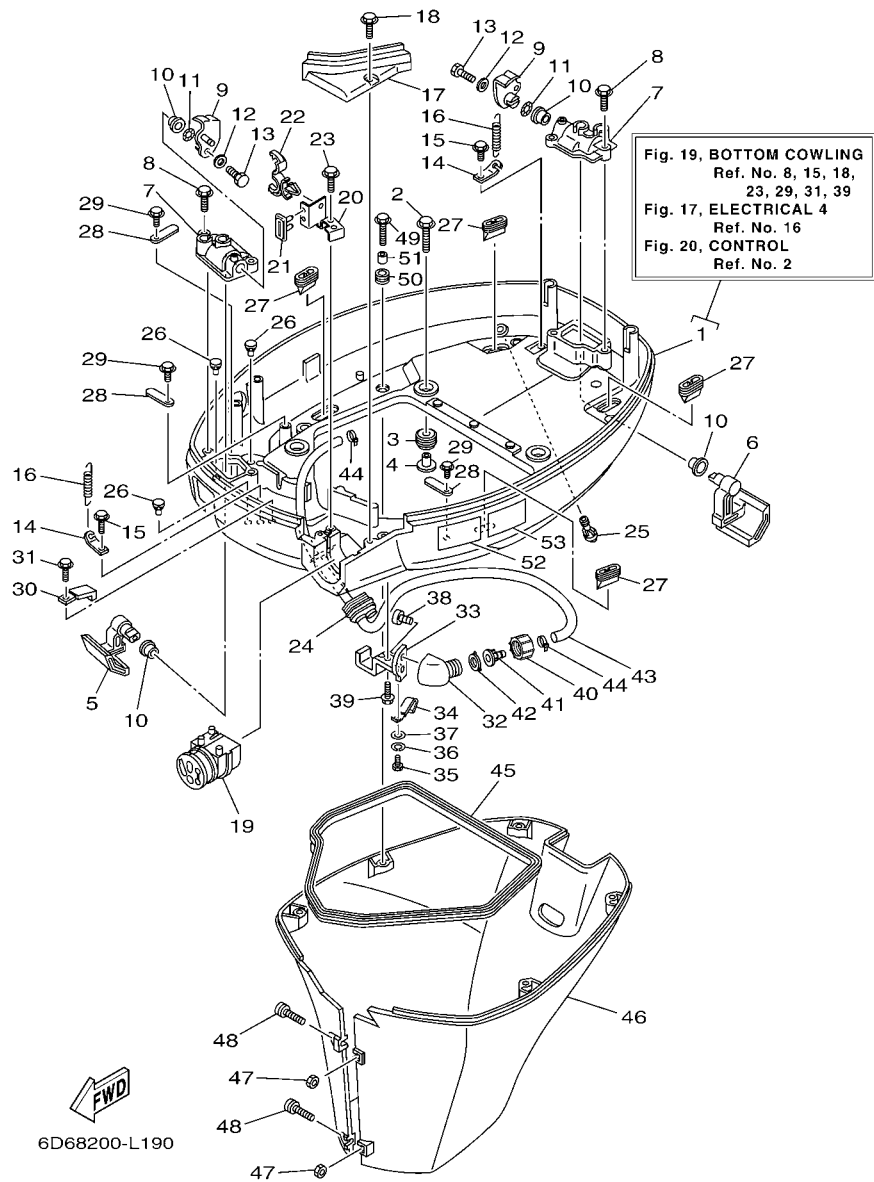
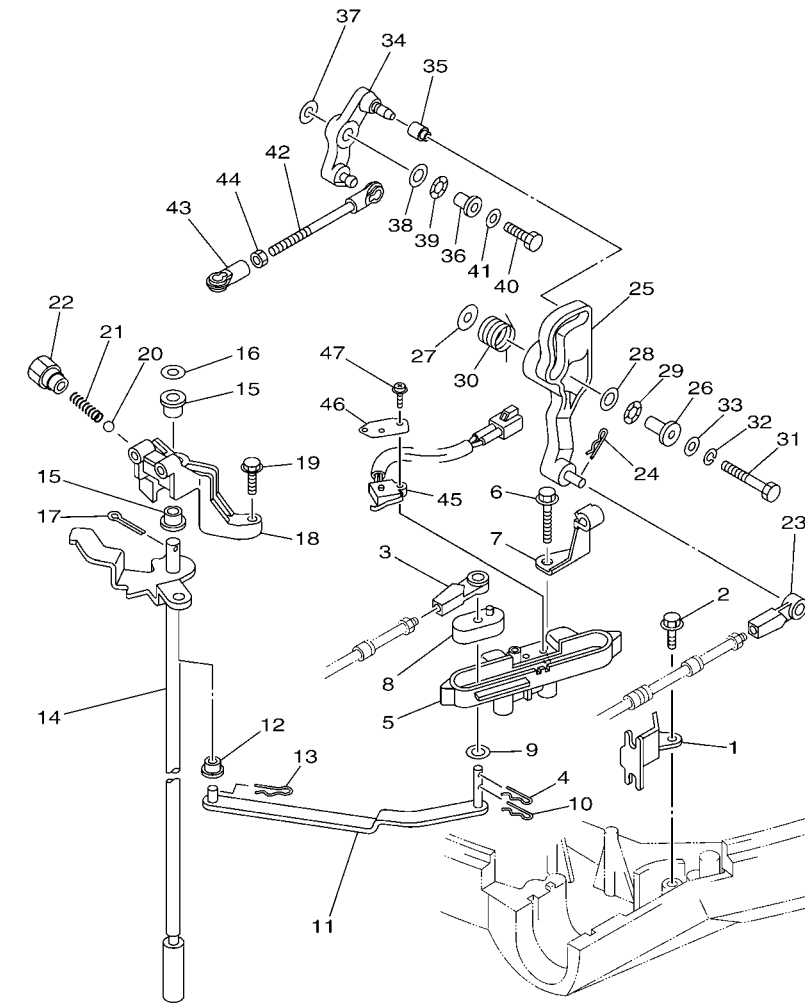

FIG. 19 BOTTOM COWLING

CUBIERTA INFERIOR

REF. NO.	PART NO. CODIGO Nº	DESCRIPTION DESCRIPCION	6D68	6D78	6D88	6D98	REMARKS OBSERVACIONES
28	6E5-82588-00	PLATE PLACA	3	3	3	3	
29	90109-06M81	BOLT PERNO	3	3	3	3	
30	90465-08M23	CLAMP BRIDA	1	1	1	1	
31	90109-06M86	BOLT PERNO	1	1	1	1	
32	68T-12572-00	ADAPTER ADAPTADOR	1	1	1	1	FLUSHING KIT FLUSHING KIT
33	67F-12535-01	PLATE EMPAQUETADURA	1	1	1	1	FLUSHING KIT FLUSHING KIT
34	90462-06018	CLAMP BRIDA	1	1	1	1	FLUSHING KIT FLUSHING KIT
35	97095-06008	BOLT PERNO	1	1	1	1	FLUSHING KIT FLUSHING KIT
36	92995-06100	WASHER, SPRING ARANDELA	1	1	1	1	FLUSHING KIT FLUSHING KIT
37	92995-06200	WASHER ARANDELA	1	1	1	1	FLUSHING KIT FLUSHING KIT
38	90167-06002	SCREW, TAPPING TORNILLO DE ROSCA HEMBRA	2	2	2	2	FLUSHING KIT FLUSHING KIT
39	90109-06M86	BOLT PERNO	1	1	1	1	FLUSHING KIT FLUSHING KIT
40	6R3-12581-00	JOINT, HOSE 1 CONEXION	1	1	1	1	FLUSHING KIT FLUSHING KIT
41	6R3-12582-00	JOINT, HOSE 2 CONEXION	1	1	1	1	FLUSHING KIT FLUSHING KIT
42	6R3-12583-00	GASKET, HOSE JOINT EMPAQUETADURA JUNTA DE MANGUE	1	1	1	1	FLUSHING KIT FLUSHING KIT
43	67F-24312-00	PIPE 2 TUBO 2	1	1	1	1	FLUSHING KIT FLUSHING KIT
44	90465-11M10	CLAMP BRIDA	2	2	2	2	FLUSHING KIT FLUSHING KIT
45	61A-42716-00	RUBBER, SEAL 1 SELLO DE GOMA 1	1	1	1	1	
46	67F-42741-01-8D	APRON MANDIL	1	1	1	1	
47	95380-06600	NUT, HEXAGON TUERCA	2	2	2	2	
48	90159-06M28	SCREW, WITH WASHER TORNILLO CON VALONA	2	2	2	2	
49	90109-06M80	BOLT PERNO	5	5	5	5	
50	90480-13M24	GROMMET TAPON	5	5	5	5	
51	90387-06M43	COLLAR ESPACIADOR	5	5	5	5	
52	6AH-42794-40	LABEL, WARNING (GENERAL) ETIQUETA DE PRECAUCION	1	1	1	1	EXCEPT FOR BRA EXCEPT FOR BRA
53	6AH-42794-70	LABEL, WARNING (GENERAL) ETIQUETA DE PRECAUCION			1		FOR BRA FOR BRA
53	6AH-42794-50	LABEL, WARNING (GENERAL) ETIQUETA DE PRECAUCION	1	1	1	1	FOR CAR FOR CAR



FWD
6D67110-K200

FIG. 20 CONTROL

CONTROL

REF. NO.	PART NO. CODIGO Nº	DESCRIPTION DESCRIPCION	6D66	6D76	6D86	6D96	REMARKS OBSERVACIONES
1	67F-48538-00	CLAMP, CABLE 1 GRAMPA DE CABLE	1	1	1	1	
2	90109-06M86	BOLT PERNO	1	1	1	1	
3	663-48344-00	CABLE END, REMOTE CONTROL BASE CONTROL	1	1	1	1	
4	90468-18008	CLIP PRESILLA	1	1	1	1	
5	6D8-44117-00-94	BRACKET SOPORTE	1	1	1	1	
6	97595-06550	BOLT, WITH WASHER PERNO CON ARANDELA	2	2	2	2	
7	90462-10027	CLAMP BRIDA	1	1	1	1	
8	68V-44122-01	BUSHING, SHIFT ROD LEVER BUJE PALANCA VARILLA DE CAMBIO	1	1	1	1	
9	90202-07M07	WASHER, PLATE ARANDELA DE PLANA	1	1	1	1	
10	90468-18008	CLIP PRESILLA	1	1	1	1	
11	67F-44121-00	LEVER, SHIFT ROD PALANCA VARILLA CAMBIOS	1	1	1	1	
12	90386-06M12	BUSH BUJE	1	1	1	1	
13	90468-18008	CLIP PRESILLA	1	1	1	1	
14	67F-44120-10 67F-44120-30	HANDLE GEAR SHIFT ASSY MANIJA DE CAMBIO COMPL HANDLE GEAR SHIFT ASSY MANIJA DE CAMBIO COMPL	1 1	1 1	1 1	1 1	L(21.1") L(21.1") X(26.1") X(26.1")
15	90386-90M90	BUSH BUJE	2	2	2	2	
16	90201-09M02	WASHER, PLATE ARANDELA PLANA	1	1	1	1	
17	91490-20015	PIN, COTTER CHAVETA	1	1	1	1	
18	67F-44118-00-94	BRACKET SOPORTE	1	1	1	1	
19	97575-06525	BOLT, WITH WASHER PERNO CON ARANDELA	2	2	2	2	
20	93501-04M02	BALL BOLA	1	1	1	1	
21	90501-12082	SPRING, COMPRESSION RESORTE DE COMPRESION	1	1	1	1	
22	648-42715-00	BUSHING BUJE	1	1	1	1	
23	663-48344-00	CABLE END, REMOTE CONTROL BASE CONTROL	1	1	1	1	
24	90468-18008	CLIP PRESILLA	1	1	1	1	
25	6D8-42154-00	LEVER, THROTTLE CONTROL PALANCA CONTROL ACELERADOR	1	1	1	1	
26	90387-06M21	COLLAR ESPACIADOR	1	1	1	1	

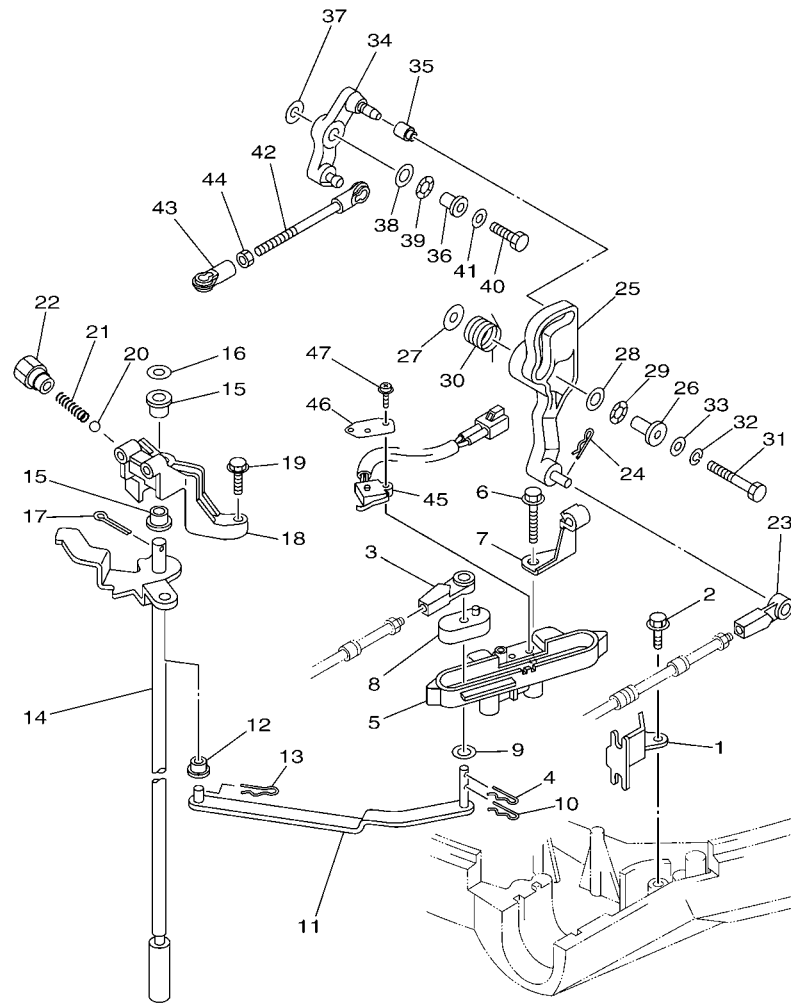

6D67110-K200

FIG. 20 CONTROL

CONTROL

REF. NO.	PART NO. CODIGO N°	DESCRIPTION DESCRIPCION	6D66	6D76	6D86	6D96	REMARKS OBSERVACIONES
27	90201-06M62	WASHER, PLATE ARANDELA PLANA	1	1	1	1	
28	90201-10M02	WASHER, PLATE ARANDELA PLANA	1	1	1	1	
29	90206-10M04	WASHER, WAVE ARANDELA ONDULADA	1	1	1	1	
30	67F-44135-00	SPRING RESORTE	1	1	1	1	
31	97095-06035	BOLT PERNO	1	1	1	1	
32	92995-06100	WASHER, SPRING ARANDELA	1	1	1	1	
33	92995-06600	WASHER ARANDELA	1	1	1	1	
34	6D8-42157-00	LEVER, THROTTLE PALANCA DE ACELERADOR	1	1	1	1	
35	68V-42171-00	BUSHING BUJE	1	1	1	1	
36	90387-06013	COLLAR ESPACIADOR	1	1	1	1	
37	90201-06M31	WASHER, PLATE ARANDELA PLANA	1	1	1	1	
38	90201-10M02	WASHER, PLATE ARANDELA PLANA	1	1	1	1	
39	90206-10M04	WASHER, WAVE ARANDELA ONDULADA	1	1	1	1	
40	97095-06025	BOLT PERNO	1	1	1	1	
41	92995-06600	WASHER ARANDELA	1	1	1	1	
42	6D8-41237-00	JOINT, LINK CONECTOR	1	1	1	1	
43	682-41237-00	JOINT, LINK CONECTOR	1	1	1	1	
44	95380-05600	NUT TUERCA	1	1	1	1	
45	60V-8259F-00	SWITCH ASSY INTERRUPTOR	1	1	1	1	
46	61A-82588-01	PLATE PLACA	1	1	1	1	
47	97985-04116	SCREW, WITH WASHER TORNILLO, CON ARANDELA	2	2	2	2	

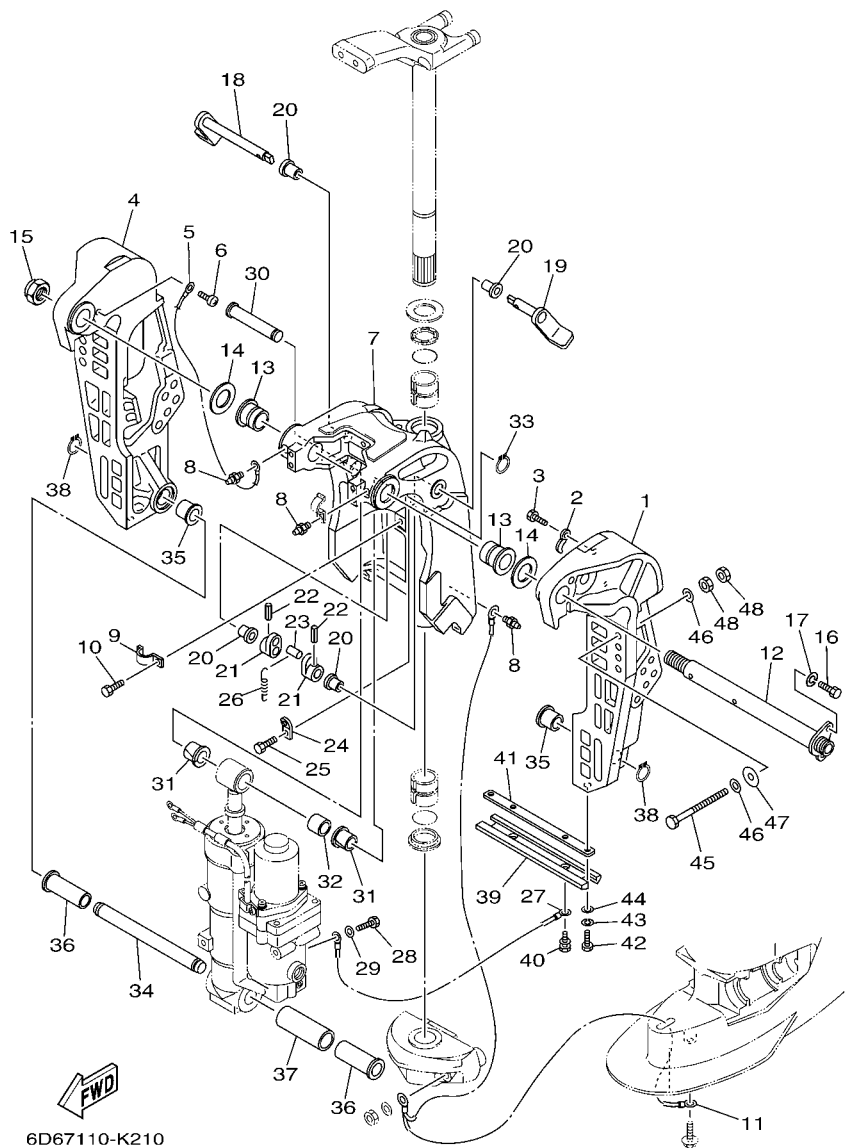

FIG. 21 BRACKET 1

SOPORTE 1

REF. NO.	PART NO. CODIGO Nº	DESCRIPTION DESCRIPCION	6D66	6D76	6D86	6D96	REMARKS OBSERVACIONES
1	67F-43111-00-8D	BRACKET, CLAMP 1 SOPORTE DE LA ABRAZADERA 1	1	1	1	1	
2	90465-10M77	CLAMP BRIDA	2	2	2	2	
3	97095-06010	BOLT PERNO	2	2	2	2	
4	67F-43112-00-8D	BRACKET, CLAMP 2 SOPORTE DE LA ABRAZADERA 2	1	1	1	1	
5	6E5-82148-00	WIRE, LEAD 4 CABLE CONDUCTOR 4	1	1	1	1	
6	97880-06012	SCREW, PAN HEAD TORNILLO DE CABEZA CON PLANA	1	1	1	1	
7	6D8-43311-00-8D	BRACKET, SWIVEL 1 SOPORTE GIRATORIO 1	1	1	1	1	
8	93700-06M03	NIPPLE, GREASE BOQUILLA DE ENGRASAR	3	3	3	3	
9	90465-08M63	CLAMP BRIDA	1	1	1	1	
10	97095-06010	BOLT PERNO	1	1	1	1	
11	67F-82127-00	WIRE, LEAD 2 CABLE CONDUCTOR 2	1	1	1	1	
12	64E-43131-01	BOLT, CLAMP BRACKET TORNILLO DE ABRAZADERA DEL SOP	1	1	1	1	
13	90386-25M31	BUSH BUJE	2	2	2	2	
14	90201-26M59	WASHER, PLATE ARANDELA PLANA	2	2	2	2	
15	90185-22M11	NUT, SELF-LOCKING TUERCA AUTOBLOCANTE	1	1	1	1	
16	97095-08020	BOLT PERNO	1	1	1	1	
17	92995-08100	WASHER ARANDELA	1	1	1	1	
18	6D8-43181-00	LEVER, TILT STOP 1 PALANCA TOPE INCLINACION 1	1	1	1	1	
19	6D8-43185-00	LEVER, TILT STOP 2 PALANCA TOPE INCLINACION 2	1	1	1	1	
20	90386-10M16	BUSH BUJE	4	4	4	4	
21	6G5-43148-00	COLLAR, DISTANCE COLLAR	2	2	2	2	
22	91690-30020	PIN, SPRING PASADOR DE RESORTE	2	2	2	2	
23	90249-06M19	PIN PASADOR	1	1	1	1	
24	66T-43144-00	HOOK, SPRING GANCHO	1	1	1	1	
25	97095-06010	BOLT PERNO	1	1	1	1	
26	90506-14M24	SPRING, TENSION RESORTE DE TENSION	1	1	1	1	
27	6D8-82148-00	WIRE, LEAD 4 CABLE CONDUCTOR 4	1	1	1	1	

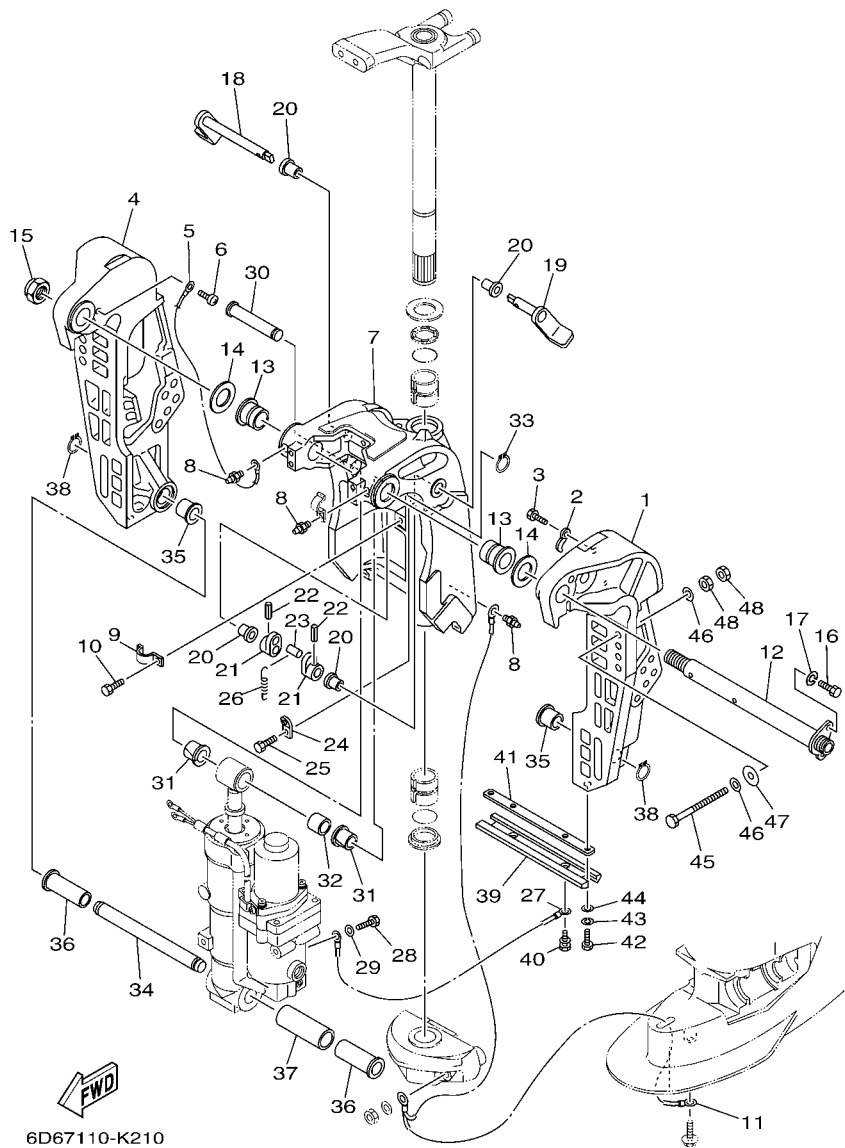
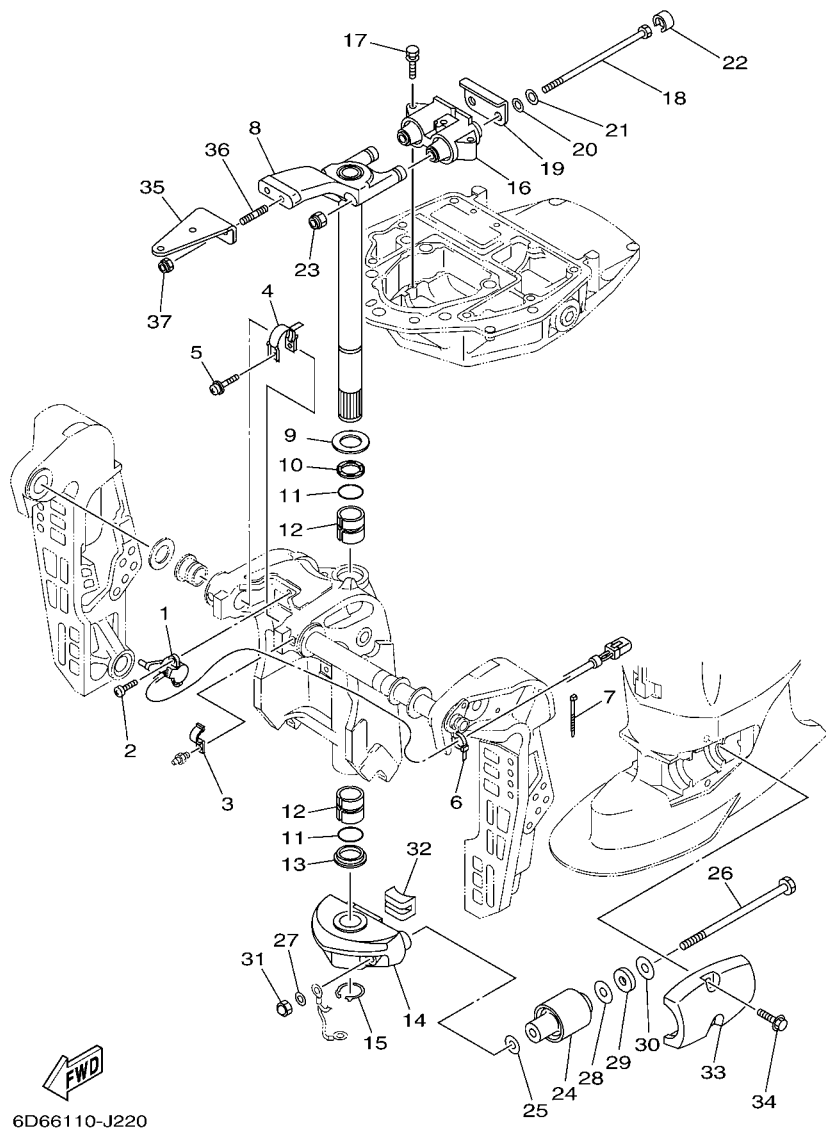

FIG. 21 BRACKET 1

SOPORTE 1

REF. NO.	PART NO. CODIGO Nº	DESCRIPTION DESCRIPCION	6D66	6D76	6D86	6D96	REMARKS OBSERVACIONES
28	97095-06010	BOLT PERNO	1	1	1	1	
29	92995-06600	WASHER ARANDELA	1	1	1	1	
30	6D8-43126-00	PIN, UPPER SHOCK MOUNT PASADOR DE AMORTIGUADOR SUPERIOR	1	1	1	1	
31	90386-18M35	BUSH BUJE	2	2	2	2	
32	90386-18001	BUSH BUJE	1	1	1	1	
33	93410-18M05	CIRCLIP SEGURO	1	1	1	1	
34	67F-43818-00	PIN, LOWER SHOCK MOUNT PASADOR AMORTIGUADOR INFERIOR	1	1	1	1	
35	90387-18M01	COLLAR ESPACIADOR	2	2	2	2	
36	90386-18MA0	BUSH BUJE	2	2	2	2	
37	90387-22M01	COLLAR ESPACIADOR	1	1	1	1	
38	93410-18M05	CIRCLIP SEGURO	2	2	2	2	
39	6H1-45251-03	ANODE CATODE	1	1	1	1	
40	90119-06M81	BOLT, WITH WASHER TORNILLO CON ARANDELA	2	2	2	2	
41	6H1-44526-00	PLATE PLACA 1	1	1	1	1	
42	97095-06016	BOLT PERNO	2	2	2	2	
43	92995-06100	WASHER, SPRING ARANDELA	2	2	2	2	
44	92995-06600	WASHER ARANDELA	2	2	2	2	
45	90101-12M03	BOLT (L:115MM) TORNILLO (L:115MM)	4	4	4	4	
	90101-12M77	BOLT (L:150MM) TORNILLO (L:150MM)			4		AP FOR BRA AP FOR BRA
46	90201-13M01	WASHER, PLATE ARANDELA PLANA	8	8	8	8	
47	90201-12426	WASHER, PLATE ARANDELA PLANA	4	4	4	4	
48	95380-12600	NUT TUERCA	8	8	8	8	



6D66110-J220

FIG. 22 BRACKET 2

SOPORTE 2

REF. NO.	PART NO. CODIGO Nº	DESCRIPTION DESCRIPCION	6D66	6D78	6D88	6D98	REMARKS OBSERVACIONES
1	67H-83672-01	TRIM SENDER TRANSMISOR DE INCLINADOR	1	1	1	1	
2	97885-06016	SCREW, PAN HEAD TORNILLO A MUESCA	2	2	2	2	
3	90465-08M63	CLAMP BRIDA	1	1	1	1	
4	64E-43139-10	CAM, TRIM SENDER LEVA TRANSMISOR DE INCLINDOR	1	1	1	1	
5	90159-05059	SCREW, WITH WASHER TORNILLO CON VALONA	1	1	1	1	
6	90465-11M10	CLAMP BRIDA	1	1	1	1	
7	90465-11M10	CLAMP BRIDA	3	3	3	3	
8	67F-42510-11-8D	STEERING BRACKET ASSY SOPORTE DIRECCION COMPL.	1	1	1	1	
9	90201-30M00	WASHER, PLATE ARANDELA PLANA	1	1	1	1	
10	90386-30M78	BUSH BUJE	1	1	1	1	
11	93210-29M94	O-RING ANILLO O	2	2	2	2	
12	90386-30M77	BUSH BUJE	2	2	2	2	
13	90386-30M60	BUSH BUJE	1	1	1	1	
14	67F-44551-00-8D	HOUSING, LOWER MOUNT RUBBER 1 CAJA AMORTIGUADOR INFERIOR HU	1	1	1	1	
15	93410-28M06	CIRCLIP SEGURO	1	1	1	1	
16	67F-44514-01	MOUNT DAMPER, UPPER SIDE AMORTIGUADOR LADO SUPERIOR	1	1	1	1	
17	90119-08091	BOLT, WITH WASHER TORNILLO CON ARANDELA	3	3	3	3	
18	90109-12007	BOLT PERNO	2	2	2	2	
19	67F-44526-00	PLATE PLACA 1	1	1	1	1	
20	90201-12M16	WASHER, PLATE ARANDELA PLANA	2	2	2	2	
21	90201-13M01	WASHER, PLATE ARANDELA PLANA	2	2	2	2	
22	67F-44533-00	DAMPER, UPPER MOUNT RUBBER AMORTIGUADOR SUPERIOR	2	2	2	2	
23	95780-12300	NUT, FLANGE TUERCA	2	2	2	2	
24	67F-44555-00	MOUNT DAMPER, LOWER SIDE AMORTIGUADOR DE HULE LADO INFE	2	2	2	2	
25	90201-13M03	WASHER, PLATE ARANDELA PLANA	2	2	2	2	
26	90109-12012	BOLT PERNO	2	2	2	2	
27	90201-12M16	WASHER, PLATE ARANDELA PLANA	2	2	2	2	

FIG. 23 OPTIONAL PARTS 1

PARTES OPCIONALES 1

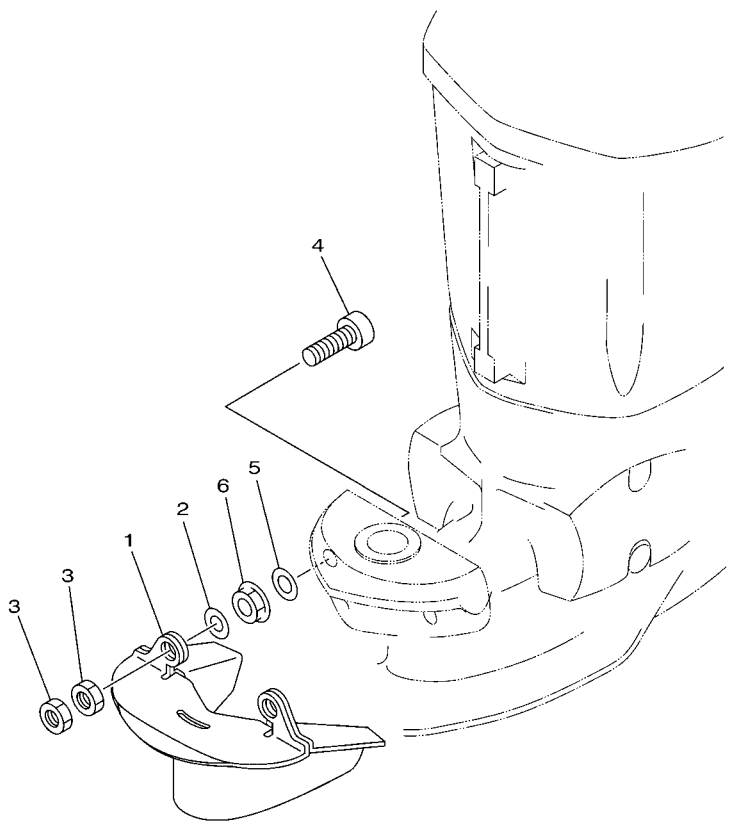

REF. NO.	PART NO. CODIGO Nº	DESCRIPTION DESCRIPCION					REMARKS OBSERVACIONES
			6D66	6D76	6D86	6D96	
1	67F-45180-00-4D	PLATE, SPLASH PLACA DESPIDENTE DE AGUA	1	1	1	1	AP AP
2	90201-12M01	WASHER, PLATE ARANDELA PLANA	2	2	2	2	AP AP
3	95380-12700	NUT TUERCA	4	4	4	4	AP AP
4	90110-12M00	BOLT, HEXAGON SOCKET HEAD TORNILLO ALLEN	2	2	2	2	AP AP
5	90201-12M16	WASHER, PLATE ARANDELA PLANA	2	2	2	2	AP AP
6	95780-12300	NUT, FLANGE TUERCA	2	2	2	2	AP AP

6D62100-E230

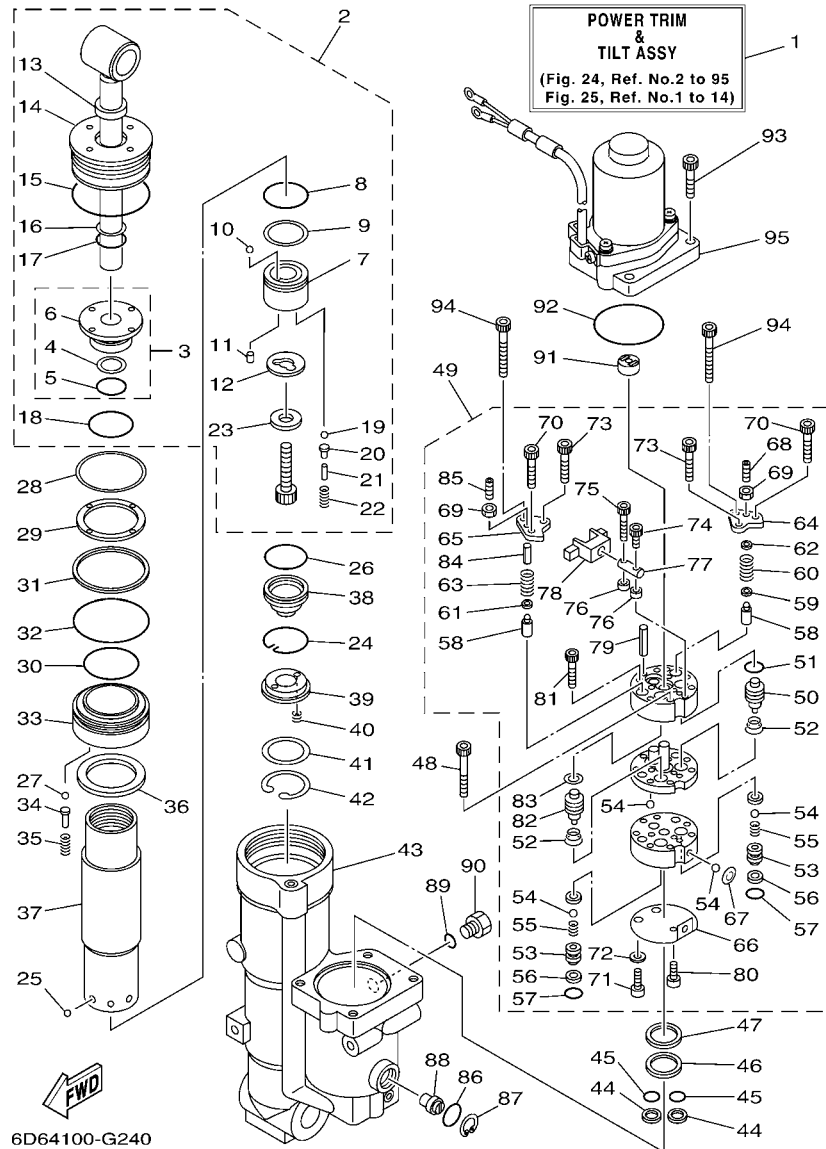

FIG. 24 POWER TRIM & TILT ASSY 1 COMPONER Y PODER VARILLA 1

REF. NO.	PART NO. CODIGO Nº	DESCRIPTION DESCRIPCION	6D66	6D76	6D86	6D96	REMARKS OBSERVACIONES
1	6D8-43800-01-8D	POWER TRIM & TILT ASSY ELEVADOR HIDRAULICO COMPL.	1	1	1	1	
2	67F-43810-01	TILT PISTON SUB ASSY ELEVADOR SUB-PISTON COMPL.	1	1	1	1	
3	67F-4380R-00	.CYLINDER END SUB ASSY .CILINDRO EXTREMO SUB-COMPLET	1	1	1	1	
4	6H1-43872-10	..RING, BACK UP ..ANILLO	1	1	1	1	
5	6D8-43863-00	..O-RING ..ANILLO EN O 3	1	1	1	1	
6	67F-43862-00	..SCREW, CYLINDER END ..CILINDURO EXTREMO	1	1	1	1	
7	67F-4385A-01	.PISTON, TILT .PISTON INCLINACION	1	1	1	1	
8	93210-29375	.O-RING .ANILLO O	1	1	1	1	
9	62X-43871-00	.RING, BACK UP .ANILLO	1	1	1	1	
10	93501-08001	.BALL .BOLA	1	1	1	1	
11	93602-07244	.PIN, DOWEL .PASADOR DE CLAVIJA	2	2	2	2	
12	67F-22435-00	.PLATE, VALVE 2 .PLACA DE VALVULA 2	1	1	1	1	
13	6H1-43812-00	.SEAL, DUST .SELLO DE POLVO	1	1	1	1	
14	67F-43821-00	.SCREW, TRIM CYLINDER END .TORNILLO CILINDURO EXTREMO	1	1	1	1	
15	67F-43861-00	.O-RING .ANILLO EN O 1	1	1	1	1	
16	6H1-43872-10	.RING, BACK UP .ANILLO	1	1	1	1	
17	6D8-43863-00	.O-RING .ANILLO EN O 3	1	1	1	1	
18	62X-43862-00	.O-RING .ANILLO EN O 2	1	1	1	1	
19	93501-08001	.BALL .BOLA	2	2	2	2	
20	65W-4386A-00	.PIN, ABSORBER VALVE .PASADOR VALVULA ABSORBER	2	2	2	2	
21	688-4386F-00	.PIN, STRAIGHT .ANILLO	2	2	2	2	
22	65W-43853-00	.SPRING, MAIN VALVE .RESORTE	2	2	2	2	
23	67F-43893-00	.WASHER .RONDANA	1	1	1	1	
24	67F-43875-00	RING, SNAP ANILLO	1	1	1	1	
25	93503-16003	BALL ESFERA	6	6	6	6	
26	67F-43863-00	O-RING ANILLO EN O 3	1	1	1	1	
27	93501-08001	BALL BOLA	5	5	5	5	

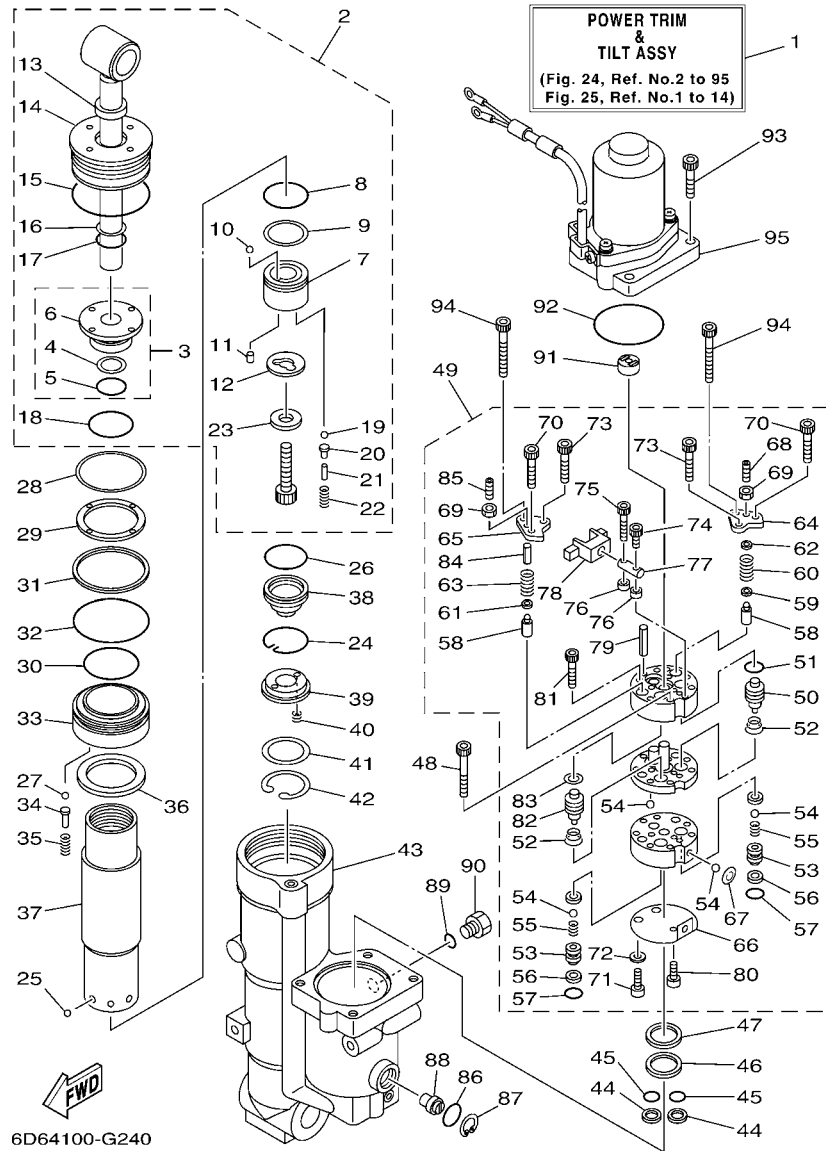
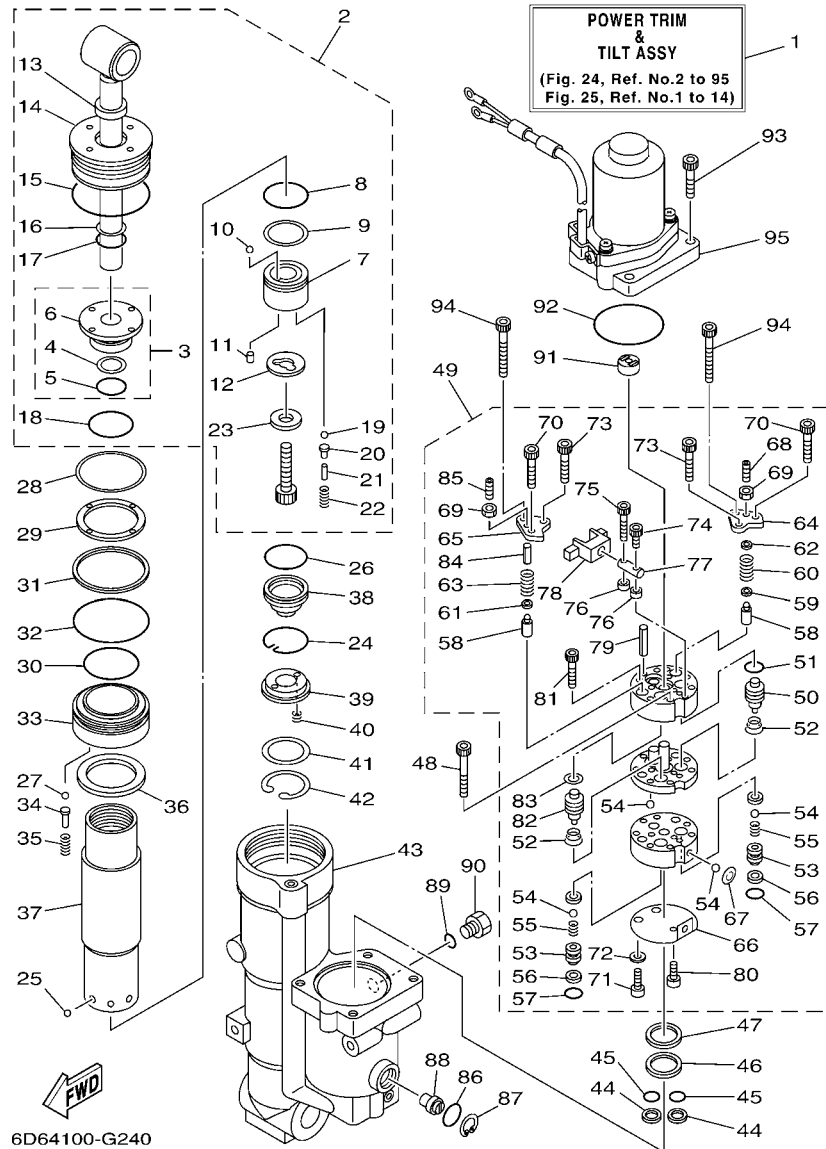

FIG. 24 POWER TRIM & TILT ASSY 1 COMPONER Y PODER VARILLA 1

REF. NO.	PART NO. CODIGO Nº	DESCRIPTION DESCRIPCION	6D66	6D78	6D88	6D98	REMARKS OBSERVACIONES
28	67F-43899-00	PLATE STOPPER PLACA	1	1	1	1	
29	67F-43816-00	FILTER 1 FILTRO 1	1	1	1	1	
30	67F-43862-00	SCREW, CYLINDER END CILINDURO EXTREMO	1	1	1	1	
31	67F-43871-00	RING, BACK UP ANILLO	1	1	1	1	
32	62X-43865-00	O-RING ANILLO EN O 5	1	1	1	1	
33	67F-4388A-00	PISTON, TRIM PISTON	1	1	1	1	
34	6T4-4386A-00	PIN, ABSORBER VALVE PASADOR VALVULA ABSORBER	5	5	5	5	
35	67F-43857-00	SPRING, ABSORBER VALVE RESORTE	5	5	5	5	
36	67F-4381J-00	PLATE PLACA	1	1	1	1	
37	67F-22471-01	CYLINDER, SHOCK ABSORBER CILINDRO DE AMORTIGUADOR	1	1	1	1	
38	67F-4381B-00	FREE PISTON SUB ASSY SUB-PISTON COMPL	1	1	1	1	
39	62X-43899-00	PLATE STOPPER PLACA	1	1	1	1	
40	62X-4384H-00	SPRING RESORTE	2	2	2	2	
41	1UF-22434-00	PLATE, VALVE 1 PLATO DE VALVULA 1	1	1	1	1	
42	62X-43875-00	RING, SNAP ANILLO	1	1	1	1	
43	6D8-4380K-00	CYLINDER, TILT SUB ASSY CILINDRO, INCLINACION	1	1	1	1	
44	6C6-43817-00	FILTER 2 FILTRO 2	2	2	2	2	
45	69J-4389J-00	O-RING ANILLO O	2	2	2	2	
46	6C5-43816-00	FILTER 1 FILTRO 1	1	1	1	1	
47	6C5-4380G-00	PLATE PLACA	1	1	1	1	
48	91318-05045	BOLT TORNILLO	2	2	2	2	
49	6D8-43830-00	GEAR PUMP ASSY ENGRANAJE BOMBA COMPL.	1	1	1	1	
50	6C6-43841-00	.PISTON, SHUTTLE .PISTON	1	1	1	1	
51	6H1-43883-00	.O-RING .ANILLO EN O 10	1	1	1	1	
52	6C6-43894-00	.SPRING, SHUTTLE RETURN .RESORTE	2	2	2	2	
53	6C6-4382E-00	.ADAPTOR 2 .ADAPTADOR 2	2	2	2	2	
54	93505-32038	.BALL .BOLA	6	6	6	6	



6D64100-G240

FIG. 24 POWER TRIM & TILT ASSY 1

COMPONER Y PODER VARILLA 1

REF. NO.	PART NO. CODIGO Nº	DESCRIPTION DESCRIPCION	6D66	6D78	6D88	6D98	REMARKS OBSERVACIONES
55	6C6-43853-00	.SPRING, MAIN VALVE .RESORTE	2	2	2	2	
56	6C6-4387G-00	.WASHER .ARANDELA	2	2	2	2	
57	69J-4389J-00	.O-RING .ANILLO O	2	2	2	2	
58	6C5-43851-00	.SEAT, RELIEF VALVE .ASIENTO VALVULA DE DESCARGA	2	2	2	2	
59	6C5-43893-00	.WASHER .RONDANA	1	1	1	1	
60	6D8-43855-00	.SPRING, UP RELIEF .RESORTE SEGURIDAD SUPERIOR	1	1	1	1	
61	6C6-43893-00	.WASHER .RONDANA	1	1	1	1	
62	6C5-4381K-00	.HOLDER .SOPORTE	1	1	1	1	
63	6D8-43856-00	.SPRING, DOWN RELIEF .RESORTE SEGURIDAD	1	1	1	1	
64	6C5-4382K-00	.CAP, RELIEF VALVE .CASQUILLO	1	1	1	1	
65	6C5-4382L-00	.CAP, RELIEF VALVE .TAPA	1	1	1	1	
66	6C5-43895-00	.SEAT, RELIEF VALVE .ASIENTO	1	1	1	1	
67	6C5-43854-00	.SPRING, MANUAL RELEASE .RESORTE DESCOPLO MANUAL	1	1	1	1	
68	92A08-03110	.SCREW SET .TORNILLO	1	1	1	1	
69	95302-03600	.NUT .TUERCA	2	2	2	2	
70	91318-05030	.BOLT .TORNILLO	2	2	2	2	
71	6C6-43878-00	.BOLT, SOCKET .TORNILLO ENCASTRE	2	2	2	2	
72	62Y-4387G-00	.WASHER .ARANDELA	2	2	2	2	
73	91318-04030	.BOLT .TORNILLO	2	2	2	2	
74	91318-03016	.BOLT .TORNILLO	1	1	1	1	
75	6C6-4388E-00	.PLUG, TAPER SCREW .TAPON	1	1	1	1	
76	6C6-4388F-00	.SPACER .ESPACIADOR	2	2	2	2	
77	6C6-4386G-00	.PIN, STRAIGHT 2 .ANILLO 2	1	1	1	1	
78	6C6-4386E-00	.LEVER 1 .PALANCA 1	1	1	1	1	
79	91609-50028	.PIN, SPRING .PASADOR DE RESORTE	2	2	2	2	
80	91318-03005	.BOLT .TORNILLO	1	1	1	1	
81	91318-05025	.BOLT .TORNILLO	2	2	2	2	

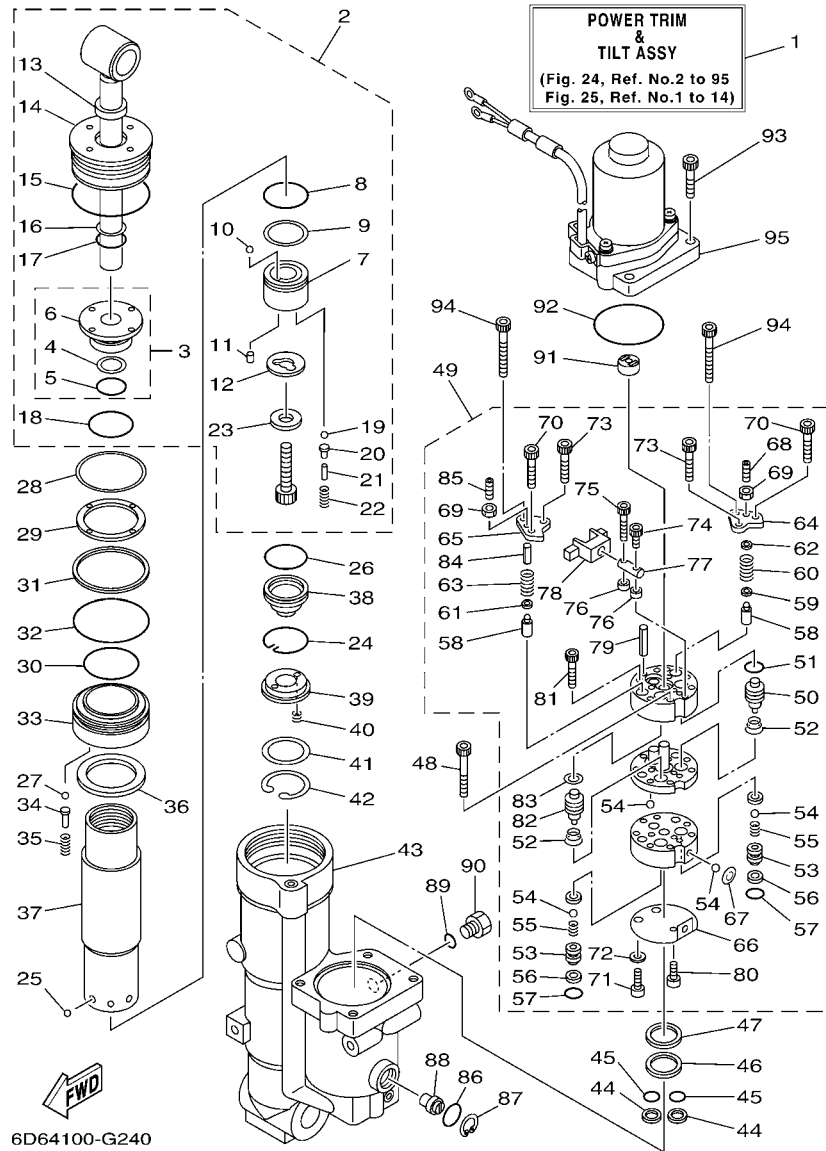

FIG. 24 POWER TRIM & TILT ASSY 1

COMPONER Y PODER VARILLA 1

REF. NO.	PART NO. CODIGO Nº	DESCRIPTION DESCRIPCION	6D66	6D76	6D86	6D96	REMARKS OBSERVACIONES
82	6C5-43841-00	.PISTON, SHUTTLE .PISTON	1	1	1	1	
83	6C5-43872-00	.RING, BACK UP .ANILLO	1	1	1	1	
84	6D8-4381G-00	.PIN 1 .PASADOR 1	1	1	1	1	
85	92A08-03012	.SCREW SET .TORNILLO	1	1	1	1	
86	6D8-43863-00	O-RING ANILLO EN O 3	1	1	1	1	
87	6H1-43875-00	RING, SNAP ANILLO	1	1	1	1	
88	6D8-43845-00	SCREW, MANUAL RELEASE TORNILLO DESCOPLO MANUAL	1	1	1	1	
89	93210-09165	O-RING ANILLO O	1	1	1	1	
90	6H1-43829-00	PLUG, RESERVOIR TAPON DEPOSITO	1	1	1	1	
91	6D8-43831-00	CONNECTOR, SHAFT CONEXION EJE	1	1	1	1	
92	93210-64488	O-RING ANILLO O	1	1	1	1	
93	65W-43888-00	BOLT, SOCKET TORNILLO ENCASTRE	4	4	4	4	
94	91318-05050	BOLT TORNILLO	2	2	2	2	
95	6D8-43880-01	MOTOR ASSY MOTOR COMPL.	1	1	1	1	REFER TO FIG.25 REFER TO FIG.25

FIG. 25 POWER TRIM & TILT ASSY 2

COMPONER Y PODER VARILLA 2

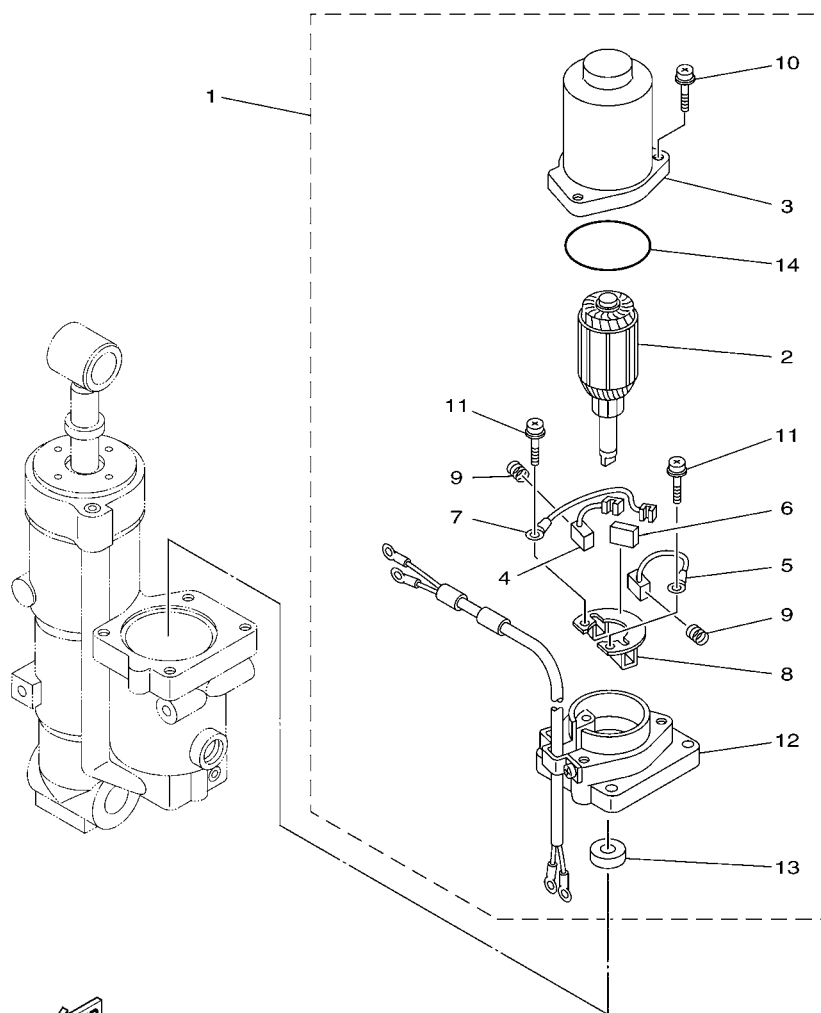

6D63100-F250

REF. NO.	PART NO. CODIGO Nº	DESCRIPTION DESCRIPCION	6D66	6D76	6D86	6D96	REMARKS OBSERVACIONES
1	6D8-43880-01	MOTOR ASSY MOTOR COMPL.	1	1	1	1	
2	6D8-43805-01	.ARMATURE ASSY .INDUCIDO COMPL.	1	1	1	1	
3	6D8-43804-01	.STATOR ASSY .ESTATOR COMPL	1	1	1	1	
4	6H1-43891-11	.BRUSH 1 .ESCOBILLA 1	1	1	1	1	
5	6H1-43892-11	.BRUSH 2 .ESCOBILLA 2	1	1	1	1	
6	6H1-82181-10	.CIRCUIT BREAKER COMP. .RUPTOR DE CIRCUITO COMPL	1	1	1	1	
7	62X-43807-00	.WIRE SUB ASSY .CABLE COMPL.	1	1	1	1	
8	6H1-4380F-11	.PLATE, BRUSH HOLDER .PLACA	1	1	1	1	
9	62X-4386K-00	.SPRING, BRUSH .RESORTE, ESCOBILLA	2	2	2	2	
10	97980-05225	.SCREW, WITH WASHER .TORNILLO, CON ARANDELA	3	3	3	3	
11	97602-04216	.SCREW, PAN HEAD WITH WASHER .TORNILLO CON RONDONA	2	2	2	2	
12	6D8-43881-01	.FRAME, END .CUADRO EXTERMO	1	1	1	1	
13	93102-08414	.OIL SEAL .SELLO ACEITE	1	1	1	1	
14	93210-554A9	.O-RING .ANILLO O	1	1	1	1	

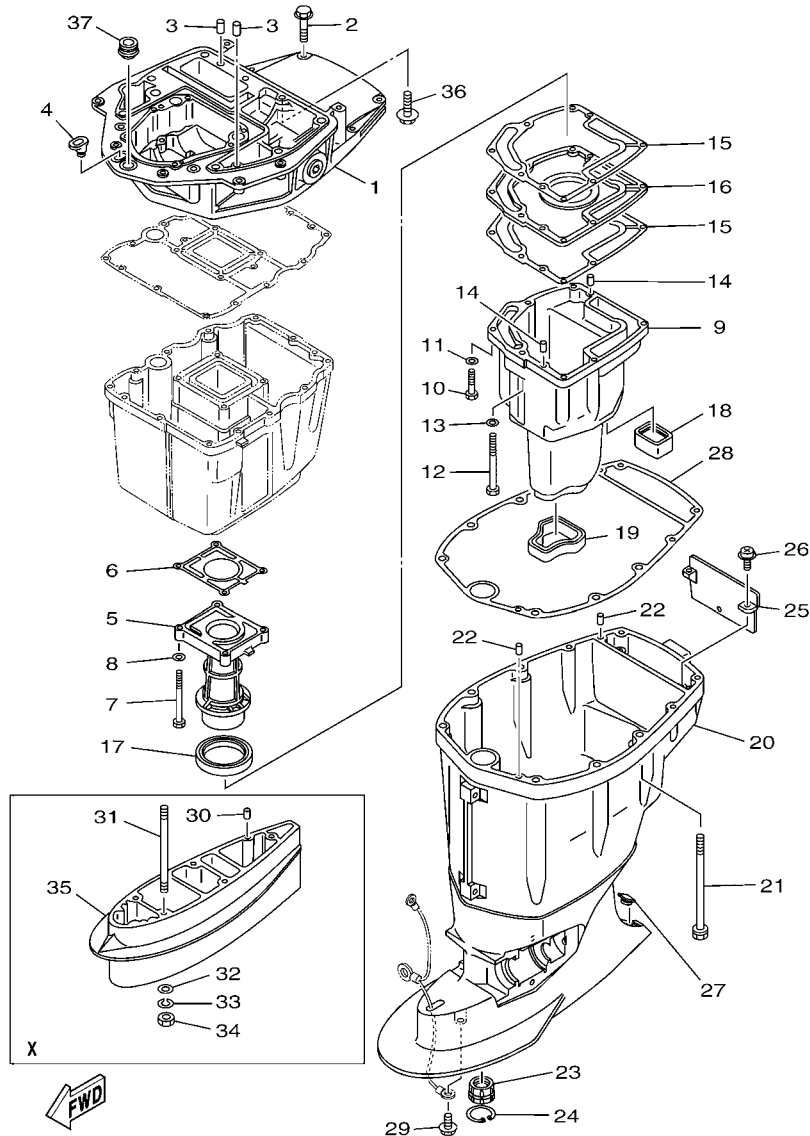

6D87110-K260

FIG. 26 UPPER CASING

FUNDA SUPERIOR

REF. NO.	PART NO. CODIGO Nº	DESCRIPTION DESCRIPCION	6D88	6D78	6D88	6D98	REMARKS OBSERVACIONES
1	6D8-41137-00-CA	GUIDE, EXHAUST GUIA DE ESCAPE	1	1	1	1	
2	97575-08540	BOLT, WITH WASHER PERNO CON ARANDELA	4	4	4	4	
3	93608-16M16	PIN, DOWEL PASADOR DE CLAVIJA	2	2	2	2	
4	6G1-42727-00	GROMMET TAPON	1	1	1	1	
5	67F-41131-01-CA	MANIFOLD, EXT. 1 TUBO MULTIPLE DE ESCAPE	1	1	1	1	
6	67F-41133-A1	GASKET, EXHAUST MANIFOLD 1 EMPAQUE ESCAPE MULTIPLE	1	1	1	1	
7	97075-06070	BOLT PERNO	4	4	4	4	
8	92995-06600	WASHER ARANDELA	4	4	4	4	
9	67F-14711-00-CA	MUFFLER 1 SILENCIADOR 1	1	1	1	1	
10	97075-06030	BOLT PERNO	6	6	6	6	
11	92995-06600	WASHER ARANDELA	6	6	6	6	
12	97075-06050	BOLT PERNO	1	1	1	1	
13	92995-06600	WASHER ARANDELA	1	1	1	1	
14	93606-19M23	PIN, DOWEL PASADOR DE CLAVIJA	2	2	2	2	
15	67F-41134-A0	GASKET, EXHAUST MANIFOLD EMPAQUE	2	2	2	2	
16	67F-45181-00-CA	PLATE PLACA	1	1	1	1	
17	67F-41138-00	SEAL, EXT. 1 SELLO, ESCAPE 1	1	1	1	1	
18	67F-45127-00	SEAL SELLO DE GOMA	1	1	1	1	
19	67F-45123-00	GASKET, MUFFLER EMPAQUE SILENCIADOR	1	1	1	1	
20	67F-45111-11-8D	CASING, UPPER CAJA SUPERIOR	1	1	1	1	
21	90119-10M08	BOLT, WITH WASHER TORNILLO CON ARANDELA	6	6	6	6	
22	93608-16M16	PIN, DOWEL PASADOR DE CLAVIJA	2	2	2	2	
23	67F-45318-00	BUSHING, DRIVE SHAFT BUJE, EJE DE MANDO	1	1	1	1	
24	93420-36M01	CIRCLIP SEGURO	1	1	1	1	
25	67F-45151-00	COVER, UPPER CASING CUBIERTA FUNDA SUPERIOR	1	1	1	1	
26	97980-06216	SCREW, WITH WASHER TORNILLO, CON ARANDELA	2	2	2	2	
27	67F-45155-00	CAP TAPA	1	1	1	1	

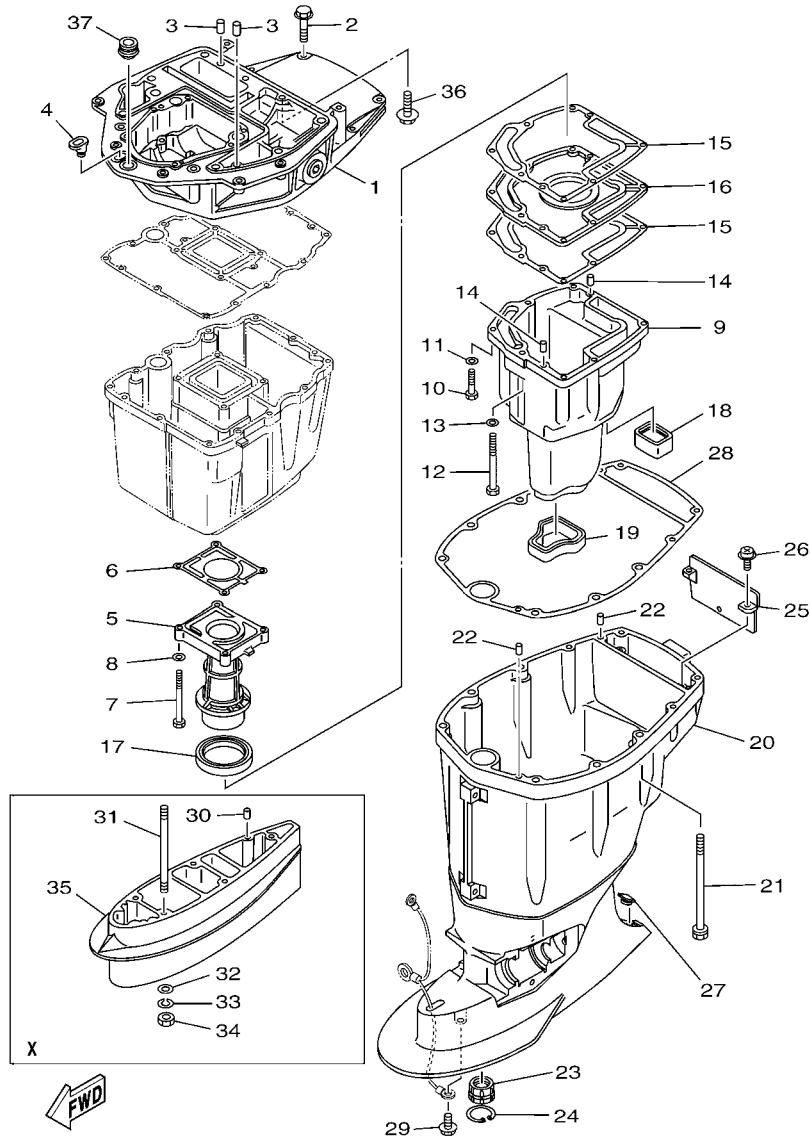

FIG. 26 UPPER CASING

FUNDA SUPERIOR

REF. NO.	PART NO. CODIGO Nº	DESCRIPTION DESCRIPCION	6D88	6D78	6D88	6D98	REMARKS OBSERVACIONES
28	67F-45113-00	GASKET, UPPER CASING EMPAQUE	1	1	1	1	
29	95895-08014	BOLT, FLANGE TORNILLO DE REBORDE	1	1	1	1	
30	93606-12019	PIN, DOWEL PASADOR DE CLAVIJA	2	2	2	2	X(26.1") X(26.1")
31	90116-10M05	BOLT, STUD ESPARRAGO	4	4	4	4	X(26.1") X(26.1")
32	92995-10600	WASHER ARANDELA	4	4	4	4	X(26.1") X(26.1")
33	92990-10100	WASHER, SPRING ARANDELA PLANA	4	4	4	4	X(26.1") X(26.1")
34	95380-10600	NUT TUERCA	4	4	4	4	X(26.1") X(26.1")
35	688-45211-01-8D	EXTENSION EXTENSION	1	1	1	1	X(26.1") X(26.1")
36	90119-08M58	BOLT, WITH WASHER TORNILLO CON ARANDELA	2	2	2	2	
37	67F-42724-00	GROMMET TAPON	1	1	1	1	

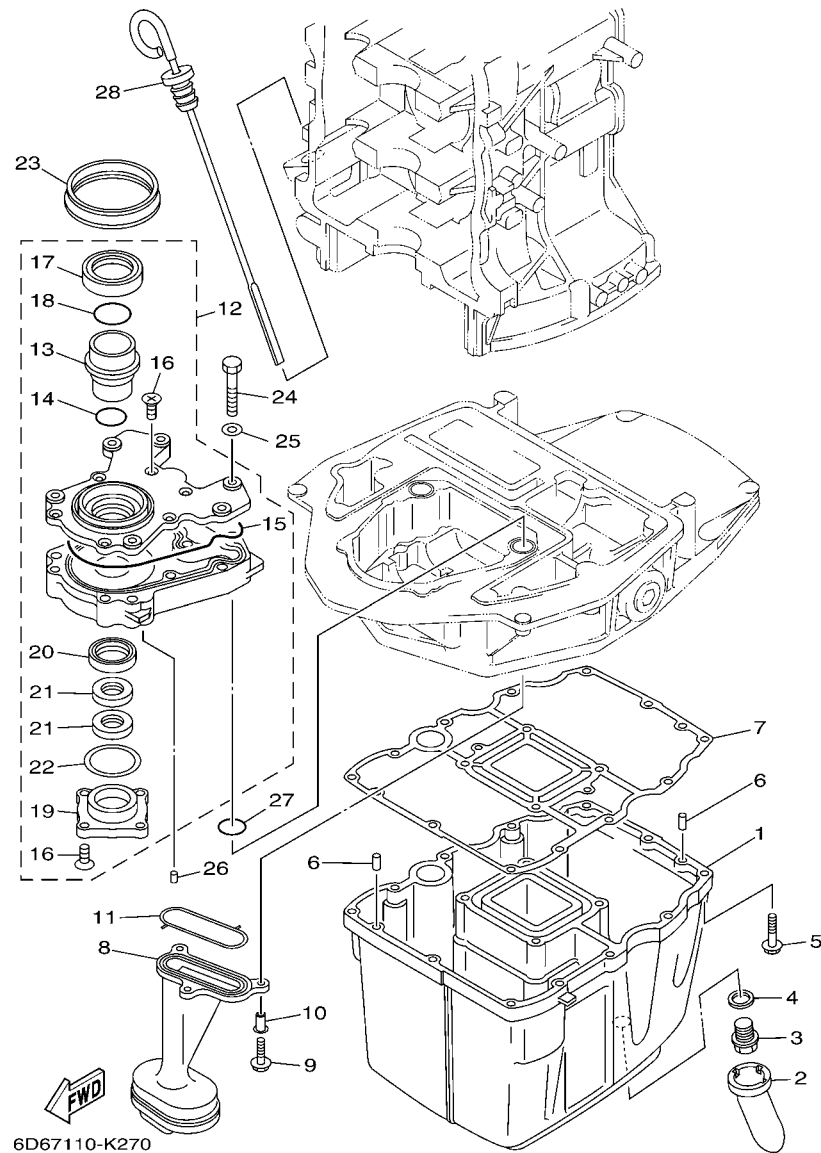

FIG. 27 OIL PAN

OIL PAN

REF. NO.	PART NO. CODIGO Nº	DESCRIPTION DESCRIPCION	6D66	6D76	6D86	6D96	REMARKS OBSERVACIONES
1	67F-15311-03-CA	OIL PAN BANDEJA DE ACEITE	1	1	1	1	
2	63P-15316-00	DAMPER 1 AMORTIGUADOR 1	1	1	1	1	
3	90340-14M06	PLUG, STRAIGHT SCREW TORNILLO, DE DRENAJE	1	1	1	1	
4	90430-14M09	GASKET JUNTA	1	1	1	1	
5	97575-06525	BOLT, WITH WASHER PERNO CON ARANDELA	12	12	12	12	
6	93606-12019	PIN, DOWEL PASADOR DE CLAVIJA	2	2	2	2	
7	68V-15312-00	GASKET, OIL PAN EMPAQ BANDEJA DE ACEITE	1	1	1	1	
8	67F-13411-00	STRAINER, OIL FILTRO DE ACEITE	1	1	1	1	
9	95812-06025	BOLT, FLANGE TORNILLO DE REBORDE	3	3	3	3	
10	90387-06263	COLLAR ESPACIADOR	3	3	3	3	
11	67F-13415-00	SEAL, OIL STRAINER SELLO COLADOR ACEITE	1	1	1	1	
12	67F-13300-10	OIL PUMP ASSY BOMBA DE ACEITE COMPLETA	1	1	1	1	
13	67F-13314-02	.SHAFT, PUMP .EJE DE BOMBA	1	1	1	1	
14	67F-13473-01	.O-RING .ANILLO O	1	1	1	1	
15	67F-13329-00	.GASKET, PUMP COVER .EMPAQUE TAPA DE BOMBA	1	1	1	1	
16	67F-13495-00	.SCREW .TORNILLO	10	10	10	10	
17	67F-13119-01	.OIL SEAL .SELLO ACEITE	1	1	1	1	
18	67F-13769-00	.O-RING .ANILLO O	1	1	1	1	
19	67F-13914-00	.HOUSING, PUMP .CAJA DE BOMBA	1	1	1	1	
20	67F-13631-03	.OIL SEAL .SELLO ACEITE	1	1	1	1	
21	67F-13149-00	.OIL SEAL .SELLO ACEITE	2	2	2	2	
22	67F-13339-00	.GASKET, PUMP COVER .EMPAQUETADURA, CUBIERTA BOMBA	1	1	1	1	
23	67F-13338-00	SEAL SELLO	1	1	1	1	
24	97095-06045	BOLT PERNO	6	6	6	6	
25	92995-06600	WASHER ARANDELA	6	6	6	6	
26	93604-12M07	PIN, DOWEL PASADOR DE CLAVIJA	2	2	2	2	
27	93210-19MJ1	O-RING ANILLO O	2	2	2	2	

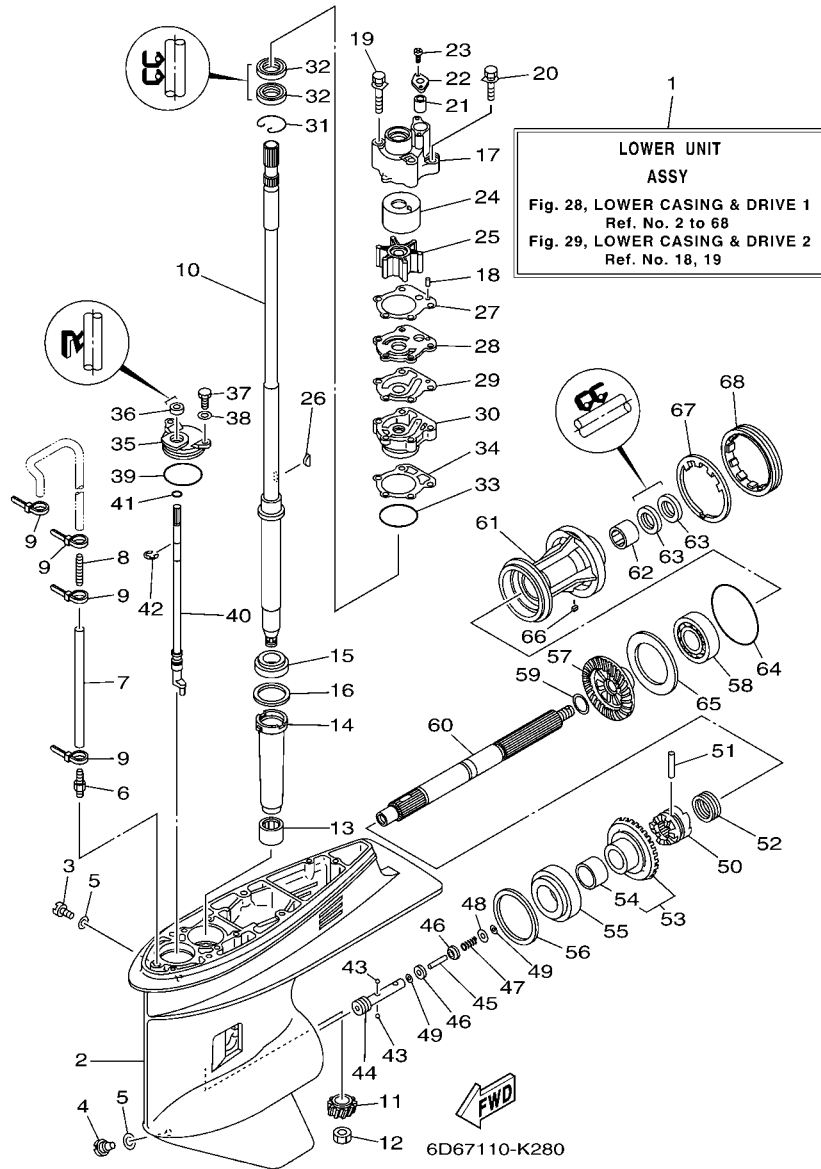

FIG. 28 LOWER CASING & DRIVE 1 IMPULSOR E INFERIOR 1

REF. NO.	PART NO. CODIGO Nº	DESCRIPTION DESCRIPCION	6D68	6D78	6D88	6D98	REMARKS OBSERVACIONES
1	6D9-45300-12-8D	LOWER UNIT ASSY CONJUNTO UNIDAD INFERIOR	1	1	1	1	L(21.1") L(21.1")
	6D9-45300-32-8D	LOWER UNIT ASSY CONJUNTO UNIDAD INFERIOR	1	1	1	1	X(26.1") X(26.1")
2	67F-45301-00-8D	CASING, LOWER FUNDA INFERIOR COMPLETA	1	1	1	1	
3	90340-08002	PLUG, STRAIGHT SCREW TORNILLO, DE DRENAJE	1	1	1	1	
4	688-45341-10	PLUG, DRAIN TAPON, DREN	1	1	1	1	
5	90430-08020	GASKET JUNTA	2	2	2	2	
6	6E5-45378-00	NIPPLE, HOSE NIPLE MANGUERA	1	1	1	1	
7	90445-07M31	HOSE (L200) TUBO (L200)	1	1	1	1	L(21.1") L(21.1")
	90445-07M38	HOSE (L300) TUBO (L300)	1	1	1	1	X(26.1") X(26.1")
8	6E5-83558-10	END, NIPPLE EXTREMO DE NIPLE	1	1	1	1	
9	90465-11M10	CLAMP BRIDA	4	4	4	4	
10	67F-45501-10	DRIVE SHAFT COMP. EJE DE MANDO COMPL.	1	1	1	1	L(21.1") L(21.1")
	67F-45501-30	DRIVE SHAFT COMP. EJE DE MANDO COMPL.	1	1	1	1	X(26.1") X(26.1")
11	6D9-45551-00	PINION (13T) PINON (13T)	1	1	1	1	
12	90170-16M01	NUT TUERCA	1	1	1	1	
13	93315-52563	BEARING COJINETE DE RODILLOS	1	1	1	1	
14	688-45536-01	SLEEVE, DRIVE SHAFT CAMISA EJE DE MANDO	1	1	1	1	
15	93332-000U3	BEARING COJINETE	1	1	1	1	
16	688-45587-01	SHIM (T:0.10MM) LAINA (T:0.10MM)	1	1	1	1	UR UR
	688-45587-10	SHIM (T:0.12MM) LAINA (T:0.12MM)	1	1	1	1	UR UR
	688-45587-20	SHIM (T:0.15MM) LAINA (T:0.15MM)	1	1	1	1	UR UR
	688-45587-30	SHIM (T:0.18MM) LAINA (T:0.18MM)	1	1	1	1	UR UR
	688-45587-40	SHIM (T:0.30MM) LAINA (T:0.30MM)	1	1	1	1	UR UR
	688-45587-50	SHIM (T:0.40MM) LAINA (T:0.40MM)	1	1	1	1	UR UR
	688-45587-60	SHIM (T:0.50MM) LAINA (T:0.50MM)	1	1	1	1	UR UR
17	67F-44311-01	HOUSING, WATER PUMP CAJA BOMBA DE AGUA	1	1	1	1	
18	93604-10M03	PIN, DOWEL PASADOR DE CLAVIJA	2	2	2	2	

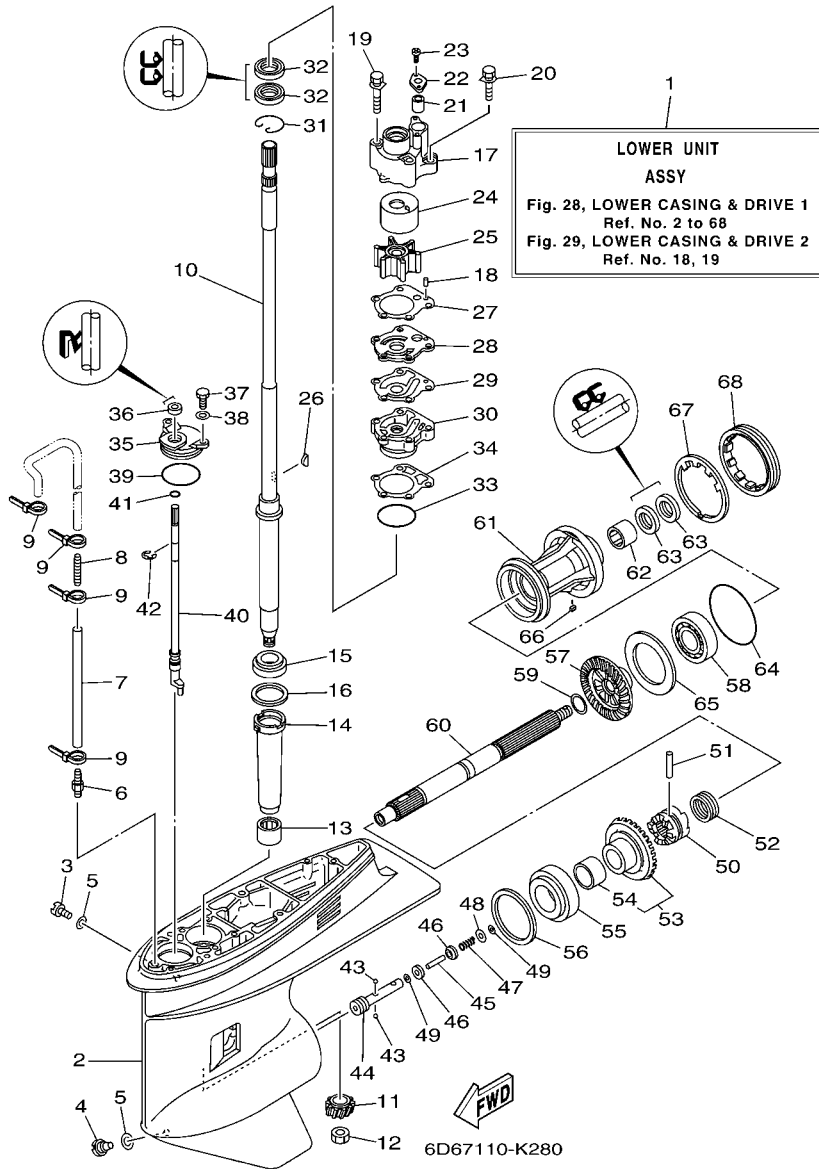

FIG. 28 LOWER CASING & DRIVE 1 IMPULSOR E INFERIOR 1

REF. NO.	PART NO. CODIGO Nº	DESCRIPTION DESCRIPCION	6D66	6D76	6D86	6D96	REMARKS OBSERVACIONES
19	90119-08M87	BOLT, WITH WASHER TORNILLO CON ARANDELA	2	2	2	2	
20	90119-08M13	BOLT, WITH WASHER TORNILLO CON ARANDELA	2	2	2	2	
21	663-44366-00	DAMPER, WATER SEAL 2 GOMA DEL SELLO DE AGUA 2	1	1	1	1	
22	90480-19M06	GROMMET TAPON	1	1	1	1	
23	90160-04006	SCREW, ROUND TAPPING TORNILLO REDONDO ROSCA HEMBRA	2	2	2	2	
24	67F-44322-00	INSERT, CARTRIDGE CARTUCHO	1	1	1	1	
25	67F-44352-00	IMPELLER IMPULSOR	1	1	1	1	
26	90280-04M04	KEY, WOODRUFF CUNA WOODRUFF	1	1	1	1	
27	688-44315-A0	GASKET, WATER PUMP EMPAQUE	1	1	1	1	
28	67F-44323-00	OUTER PLATE, CARTRIDGE PLACA EXTERIOR DEL CARTUCHO	1	1	1	1	
29	688-44324-A0	GASKET, CARTRIDGE EMPAQUE	1	1	1	1	
30	6D8-44341-01-CA	HOUSING, WATER PUMP CAJA BOMBA DE AGUA	1	1	1	1	
31	93450-44166	CIRCLIP SEGURO	1	1	1	1	
32	93101-25M03	OIL SEAL SELLO ACEITE	2	2	2	2	
33	93210-46044	O-RING ANILLO O	1	1	1	1	
34	688-44316-A0	GASKET, WATER PUMP EMPAQUE	1	1	1	1	
35	688-45321-00	PLATE PLACA	1	1	1	1	
36	93106-09014	OIL SEAL SELLO ACEITE	1	1	1	1	
37	97095-06016	BOLT PERNO	2	2	2	2	
38	92995-06600	WASHER ARANDELA	2	2	2	2	
39	93210-49046	O-RING ANILLO O	1	1	1	1	
40	67F-44150-01	SHIFT CAM ASSY CONJUNTO EJE LEVA COMPL.	1	1	1	1	
41	93210-07003	O-RING ANILLO O	1	1	1	1	
42	99001-08600	CIRCLIP PRESILLA REDONDA	1	1	1	1	
43	93503-16003	BALL ESFERA	2	2	2	2	
44	67F-45634-00	SLIDE, SHIFT DESILIZADOR, CAMBIO	1	1	1	1	
45	6H1-45668-00	SHAFT, FREE 1 EJE 1	1	1	1	1	

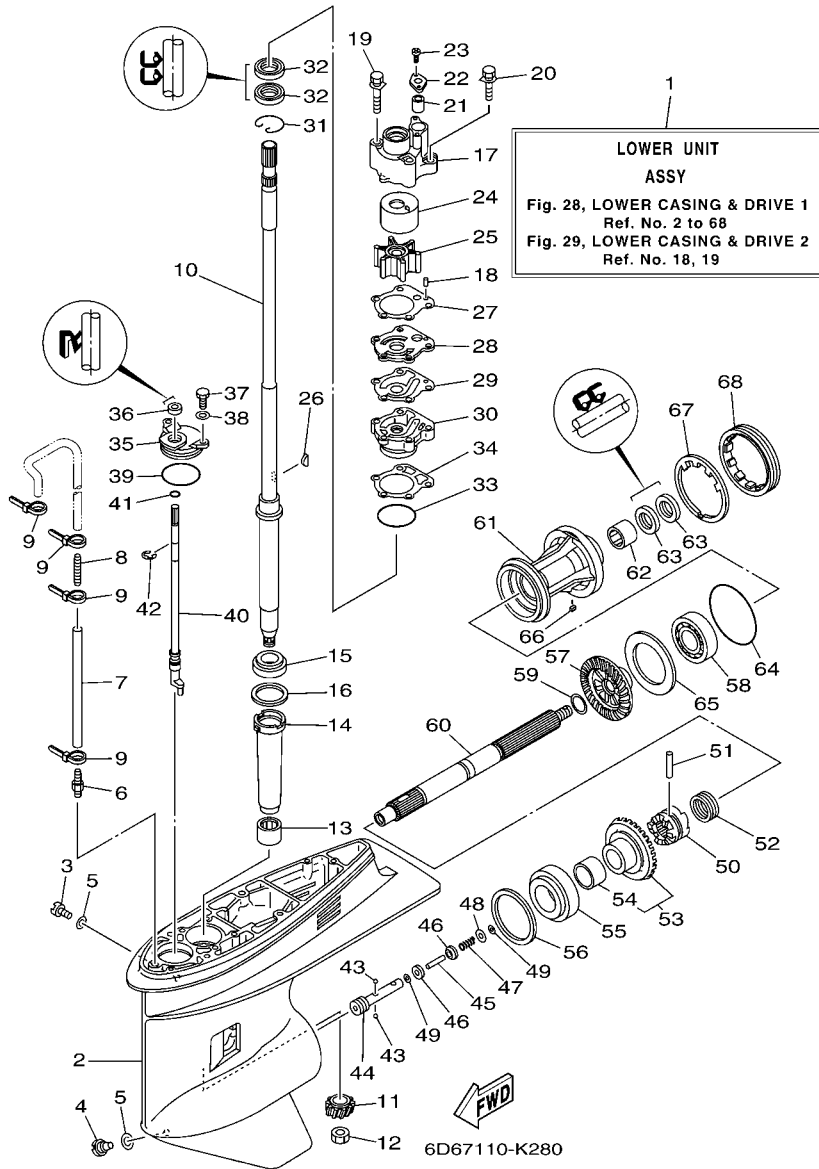

FIG. 28 LOWER CASING & DRIVE 1 IMPULSOR E INFERIOR 1

REF. NO.	PART NO. CODIGO Nº	DESCRIPTION DESCRIPCION					REMARKS OBSERVACIONES
			6D68	6D78	6D88	6D98	
46	6H1-45635-00	PLUNGER, SHIFT EMBOLO DE CAMBIO	2	2	2	2	
47	90501-12M48	SPRING, COMPRESSION RESORTE DE COMPRESION	1	1	1	1	
48	90201-03313	WASHER, PLATE ARANDELA PLANA	1	1	1	1	
49	90183-02M03	NUT, SPRING TUERCA DE RESORTE	2	2	2	2	
50	6D8-45631-00	CLUTCH, DOG EMBRAGUE DE GARRA	1	1	1	1	
51	90250-07M02	PIN, STRAIGHT PASADOR CILINDRICO	1	1	1	1	
52	688-45633-00	RING, CROSS PIN ANILLO DE PASADOR	1	1	1	1	
53	67F-45560-00	GEAR 1 (30T) ENGRANAJE 1 (30T)	1	1	1	1	
54	93317-322V0	.BEARING .COJINETE	1	1	1	1	
55	93332-000UD	BEARING COJINETE	1	1	1	1	
56	688-45567-01	SHIM (T:0.10MM) LAINA (T:0.10MM)	1	1	1	1	UR
	688-45567-10	SHIM (T:0.12MM) LAINA (T:0.12MM)	1	1	1	1	UR
	688-45567-20	SHIM (T:0.15MM) LAINA (T:0.15MM)	1	1	1	1	UR
	688-45567-30	SHIM (T:0.18MM) LAINA (T:0.18MM)	1	1	1	1	UR
	688-45567-40	SHIM (T:0.30MM) LAINA (T:0.30MM)	1	1	1	1	UR
	688-45567-50	SHIM (T:0.40MM) LAINA (T:0.40MM)	1	1	1	1	UR
	688-45567-60	SHIM (T:0.50MM) LAINA (T:0.50MM)	1	1	1	1	UR
57	6D9-45571-00	GEAR 2 (30T) ENGRANAJE 2 (30T)	1	1	1	1	
58	93306-207U0	BEARING COJINETE	1	1	1	1	
59	90201-25M05	WASHER, PLATE ARANDELA PLANA	1	1	1	1	
60	67F-45611-01	SHAFT, PROPELLER EJE PROPUSOR	1	1	1	1	
61	67F-45331-00-CA	HOUSING, BEARING CAJA DE COJINETE	1	1	1	1	
62	93317-325U0	BEARING COJINETE	1	1	1	1	
63	93101-25M03	OIL SEAL SELLO ACEITE	2	2	2	2	
64	93210-86M39	O-RING ANILLO O	1	1	1	1	
65	67F-45576-00	WASHER, THRUST 2 ARANDELA DE EMPUJE AXIAL 2	1	1	1	1	
66	90282-04010	KEY, STRAIGHT CHAVETA, RECTA	1	1	1	1	

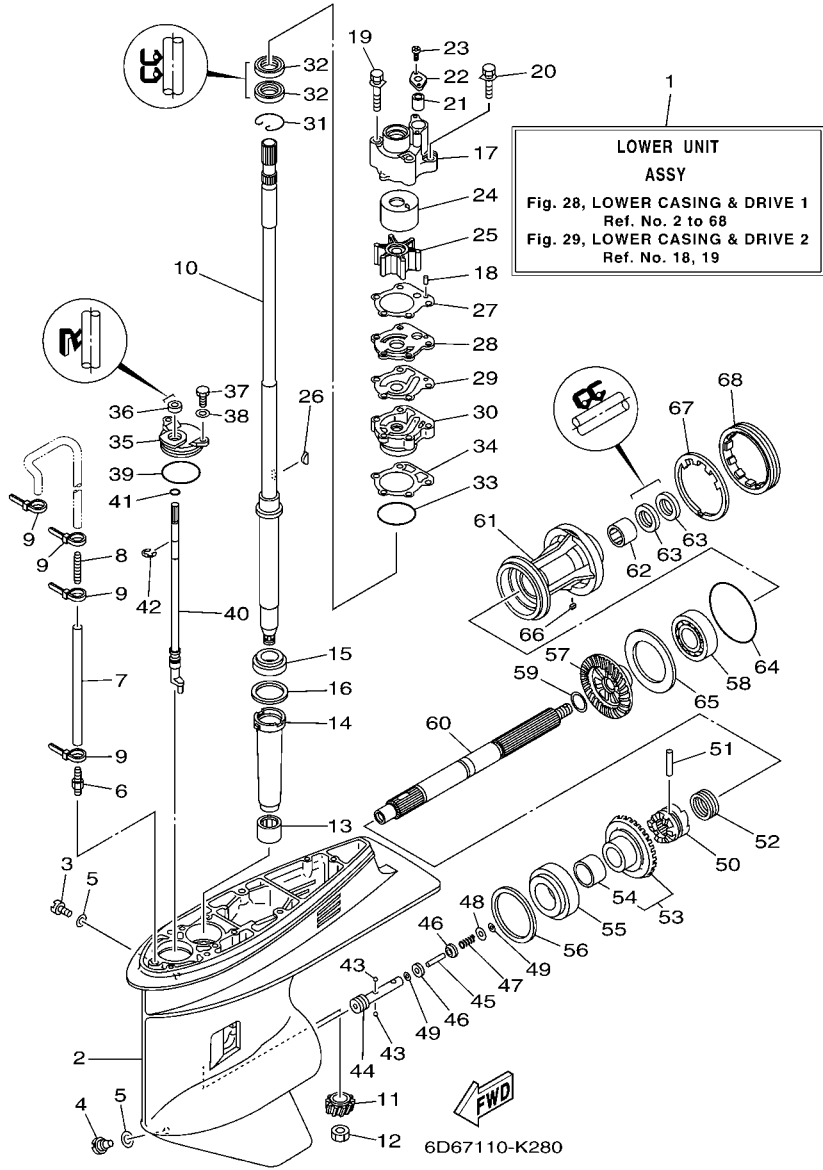
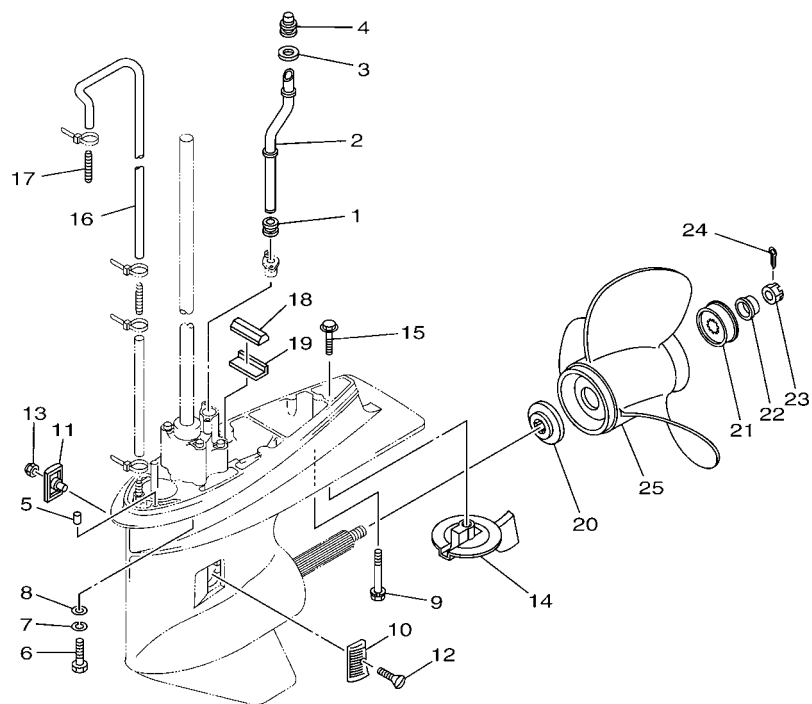

FIG. 28 LOWER CASING & DRIVE 1 IMPULSOR E INFERIOR 1

REF. NO.	PART NO. CODIGO Nº	DESCRIPTION DESCRIPCION	6D66	6D76	6D86	6D96	REMARKS OBSERVACIONES
67	688-45383-02	WASHER, CLAW ARANDELA DE UNA	1	1	1	1	
68	688-45384-02	NUT TUERCA	1	1	1	1	

FIG. 29 LOWER CASING & DRIVE 2 IMPULSOR E INFERIOR 2



6D81100-D320

REF. NO.	PART NO. CODIGO Nº	DESCRIPTION DESCRIPCION	6D66	6D76	6D86	6D96	REMARKS OBSERVACIONES
1	663-44367-00	DAMPER, WATER SEAL 3 GOMA DEL SELLO DE AGUA 3	1	1	1	1	
2	6D8-44361-00	TUBE, WATER 1 TUBO DE AGUA 1	1	1	1	1	L(21.1") L(21.1")
	6D8-44361-10	TUBE, WATER 1 TUBO DE AGUA 1	1	1	1	1	X(26.1") X(26.1")
3	6D8-44314-00	SPACER ESPACIADOR	1	1	1	1	
4	67F-44365-00	DAMPER, WATER SEAL 1 HULE DE SELLO DE AGUA 1	1	1	1	1	
5	93606-12019	PIN, DOWEL PASADOR DE CLAVIJA	2	2	2	2	
6	97075-10040	BOLT PERNO	4	4	4	4	L(21.1") L(21.1")
7	92995-10100	WASHER ARANDELA	4	4	4	4	L(21.1") L(21.1")
8	92995-10600	WASHER ARANDELA	4	4	4	4	L(21.1") L(21.1")
9	90119-08M84	BOLT, WITH WASHER TORNILLO CON ARANDELA	1	1	1	1	L(21.1") L(21.1")
	90119-08M86	BOLT, WITH WASHER TORNILLO CON ARANDELA	1	1	1	1	X(26.1") X(26.1")
10	6H1-45214-00	COVER, WATER INLET 1 CUBIERTA ENTRADA AGUA 1	1	1	1	1	
11	6H1-45215-00	COVER, WATER INLET 2 CUBIERTA ENTRADA AGUA 2	1	1	1	1	
12	90151-05M00	SCREW, COUNTERSUNK TORNILLO EMBUTIDO	1	1	1	1	
13	90185-05002	NUT, NYLON TUERCA AUTOBLOCANTE	1	1	1	1	
14	67F-45371-00	TAB-TRIM QUILLA ESTABILIZADOR	1	1	1	1	
15	90105-10M67	BOLT, FLANGE TORNILLO	1	1	1	1	
16	90445-07ME0	HOSE (L1220) TUBO (L1220)	1	1	1	1	
17	6E5-83558-00	END, NIPPLE EXTREMO DE NIPLE	1	1	1	1	
18	688-45375-00	DAMPER, SEAL GOMA DE SELLO	1	1	1	1	
19	663-45376-00	GUIDE, SEAL DAMPER GUIA DE SELLO GOMA	1	1	1	1	
20	688-45987-01	SPACER 1 ESPACIADOR 1	1	1	1	1	
21	67F-45997-00	SPACER 2 ESPACIADOR 2	1	1	1	1	
22	90389-25M00	BUSH BUJE	1	1	1	1	
23	90171-16011	NUT, CASTLE TUERCA ENTALLADA	1	1	1	1	
24	91490-40025	PIN, COITER CHAVETA	1	1	1	1	
25	6E5-45941-00	PROPELLER (3X13"X19"-K) PROPELA (3X13"X19"-K)	1	1	1	1	UR UR

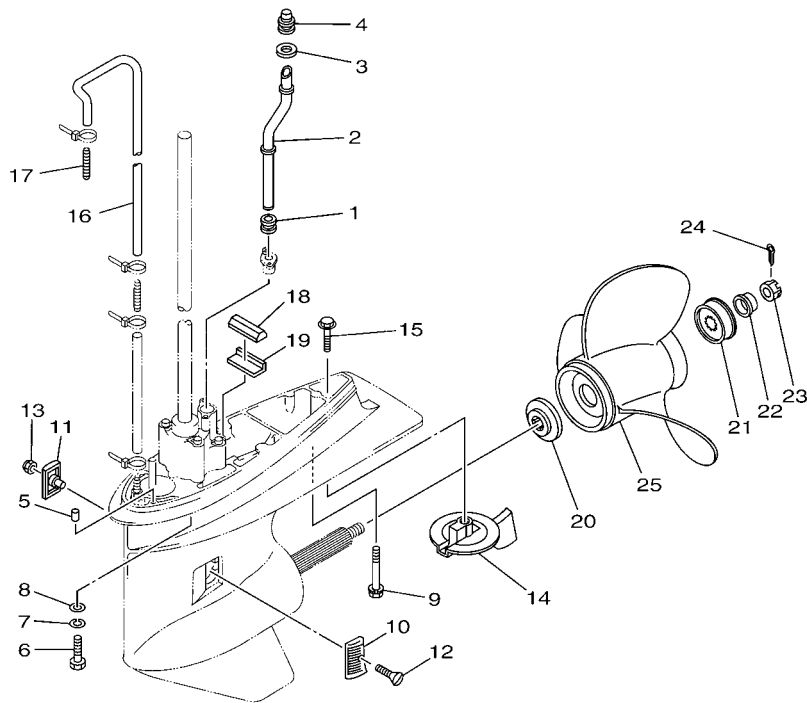

6D81100-D320

FIG. 29 LOWER CASING & DRIVE 2 IMPULSOR E INFERIOR 2

REF. NO.	PART NO. CODIGO Nº	DESCRIPTION DESCRIPCION					REMARKS OBSERVACIONES
			6D88	6D78	6D88	6D98	
25	6E5-45943-00	PROPELLER (3X12-5/8"X21"-K) PROPELA (3X12-5/8"X21"-K)	1	1	1	1	UR UR
	6E5-45945-01	PROPELLER (3X13-1/4"X17"-K) PROPELA (3X13-1/4"X17"-K)	1	1	1	1	UR UR
	6E5-45947-00	PROPELLER (3X13-1/2"X15"-K) PROPELA (3X13-1/2"X15"-K)	1	1	1	1	UR UR
	6E5-45949-00	PROPELLER (3X13-5/8"X13"-K) PROPELA (3X13-5/8"X13"-K)	1	1	1	1	UR UR
	6E5-45952-00	PROPELLER (3X13"X23"-K) PROPELA (3X13"X23"-K)	1	1	1	1	UR UR
	6E5-45954-00	PROPELLER (3X14"X11"-K) PROPELA (3X14"X11"-K)	1	1	1	1	UR UR
	6E5-45956-00	PROPELLER (3X13"X25"-K) PROPELA (3X13"X25"-K)	1	1	1	1	UR UR
	6E5-45958-00	PROPELLER (3X13-5/8"X14"-K) PROPELA (3X13-5/8"X14"-K)	1	1	1	1	UR UR
	688-45970-03	PROPELLER (3X13"X19"-K) PROPELA (3X13"X19"-K)	1	1	1	1	UR UR
	688-45972-02	PROPELLER (3X13"X21"-K) PROPELA (3X13"X21"-K)	1	1	1	1	UR UR
	688-45974-02	PROPELLER (3X13"X23"-K) PROPELA (3X13"X23"-K)	1	1	1	1	UR UR
	688-45976-01	PROPELLER (3X13"X25"-K) PROPELA (3X13"X25"-K)	1	1	1	1	UR UR
	688-45978-60	PROPELLER (3X13-1/2"X16"-K) PROPELA (3X13-1/2"X16"-K)	1	1	1	1	UR UR
	688-45930-02	PROPELLER (3X13"X17"-K2) PROPELA (3X13"X17"-K2)	1	1	1	1	UR UR
	688-45932-60	PROPELLER (3X13-1/2"X14"-K) PROPELA (3X13-1/2"X14"-K)	1	1	1	1	UR UR

FIG. 30 FUEL TANK 1

DEPOSITO DE COMBUSTIBLE 1

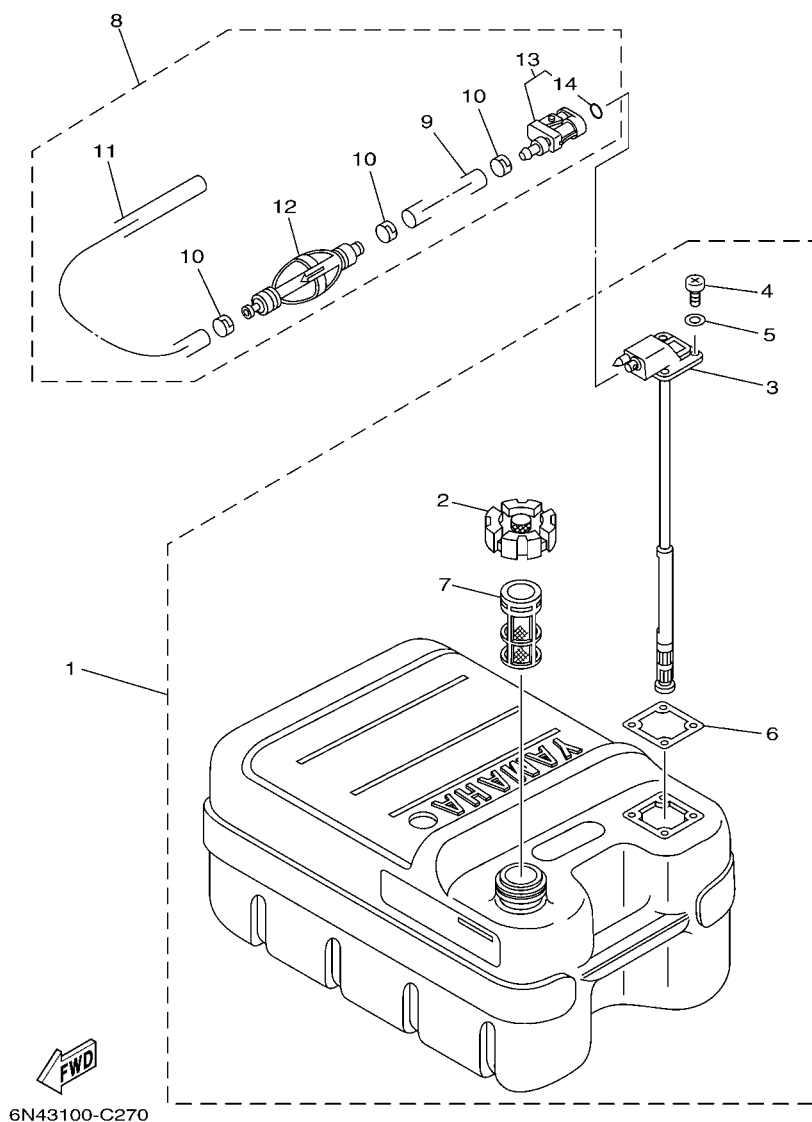

REF. NO.	PART NO. CODIGO Nº	DESCRIPTION DESCRIPCION	6D66	6D76	6D86	6D96	REMARKS OBSERVACIONES
1	6YJ-24201-00	FUEL TANK ASSY (24L) TANQUE DEL COMBUSTIBLE (24L)		1	1		AP CAR,CAR(CE) AP CAR,CAR(CE)
	6YJ-24201-10	FUEL TANK ASSY (24L) TANQUE DEL COMBUSTIBLE (24L)		1			AP CHN AP CHN
2	6YJ-24610-01	.CAP ASSY .TAPA COMPLETA		1	1		
3	6YJ-24260-00	.FUEL METER ASSY .MEDIDOR DE COMBUSTIBLE COMPL.		1	1		FOR 6YJ-24201-00 FOR 6YJ-24201-10
	6Y1-24260-12	.FUEL METER ASSY .MEDIDOR DE COMBUSTIBLE COMPL.		1			FOR 6YJ-24201-10 FOR 6YJ-24201-10
4	90157-05M19	.SCREW, PAN HEAD .TORNILLO CABEZA CONICA PLANA		4	4		
5	6Y1-24329-00	.SEAL .SELLO		4	4		
6	6Y1-24268-00	.GASKET, FUEL METER .EMPAQ MEDIDOR DE COMBUSTIBLE		1	1		
7	6YJ-24167-00	.STRAINER .COLADOR		1	1		
8	6Y2-24306-45	FUEL PIPE COMP. 1 TUBO COMBUST. COMPL 1		1	1		AP CAR,CAR(CE),CHN AP CAR,CAR(CE),CHN
9	90445-13M01	.HOSE (L2050) .MANGUERA (L2050)		1	1		
10	6E5-24351-51	.BAND 1 .ABRAZADERA 1		3	3		
11	90445-13M35	.HOSE (L250) .MANGUERA (L250)		1	1		
12	6Y2-24360-60	.PRIMER PUMP ASSY .SOPORTE BOMBA		1	1		
13	6Y2-24305-06	.FUEL PIPE JOINT COMP. 2 .CONECTOR MANGUERA COMBUST. 2		1	1		
14	93210-08287	..O-RING ..ANILLO O		1	1		

FIG. 31 FUEL TANK 2

DEPOSITO DE COMBUSTIBLE 2

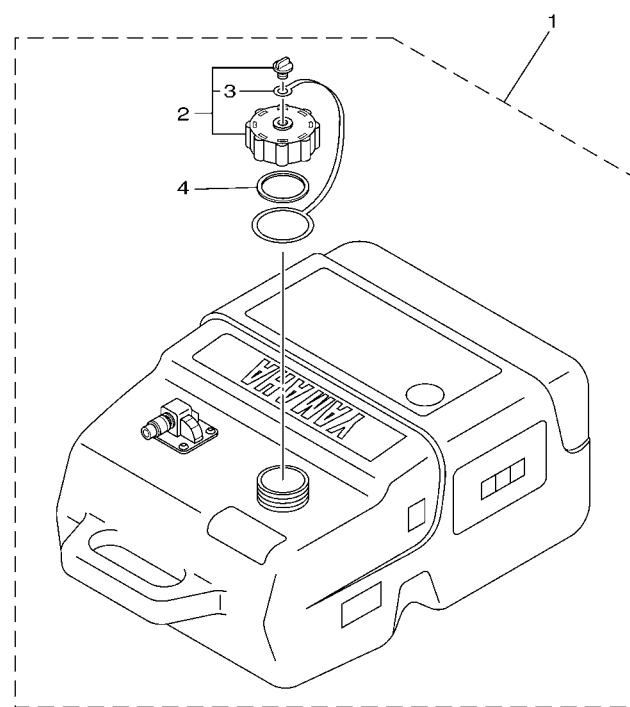
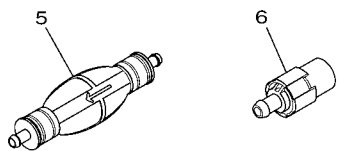

6D68200-L310

REF. NO.	PART NO. CODIGO Nº	DESCRIPTION DESCRIPCION	6D68	6D78	6D88	6D98	REMARKS OBSERVACIONES
1	6YK-24201-41	FUEL TANK ASSY (25L) TANQUE DEL COMBUSTIBLE (25L)	1		1		AP FOR CAR(EPA) AP FOR CAR(EPA)
2	6YL-24610-10	.CAP ASSY .TAPA COMPLETA	1		1		
3	6YL-24641-10	..GASKET, CAP 1 ..EMPAQUE DE TAPA 1	1		1		
4	6YL-24629-00	.RING .ANILLO	1		1		
5	6YK-24360-71	PRIMER PUMP ASSY SOPORTE BOMBA	1		1		AP FOR CAR(EPA) AP FOR CAR(EPA)
6	6YK-24305-00	FUEL PIPE JOINT COMP. 2 CONECTOR MANGUERA COMBUST. 2	1		1		AP FOR CAR(EPA) AP FOR CAR(EPA)

FIG. 32 STEERING GUIDE

DIRECCIONGUIAR

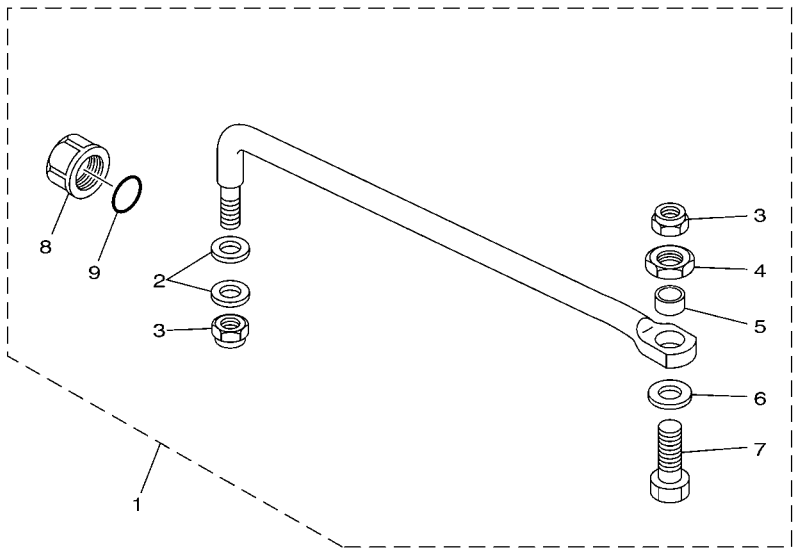

67F0010-9250

REF. NO.	PART NO. CODIGO Nº	DESCRIPTION DESCRIPCION	6D66	6D76	6D88	6D98	REMARKS OBSERVACIONES
1	67F-61350-00	STEERING GUIDE ATTACHMENT KIT ESTUCHE ADITAMENTO GUIA DE TIM	1	1	1	1	AP AP
2	90201-10M20	.WASHER, PLATE .ARANDELA PLANA	2	2	2	2	
3	90185-09M01	.NUT, SELF-LOCKING .TUERCA AUTOBLOCANTE	2	2	2	2	
4	90170-09M03	.NUT .TUERCA	1	1	1	1	
5	90387-10M42	.COLLAR .ESPACIADOR	1	1	1	1	
6	90201-10M63	.WASHER, PLATE .ARANDELA PLANA	1	1	1	1	
7	90101-09M01	.BOLT .TORNILLO	1	1	1	1	
8	6E5-43145-01	.CAP, CLAMP BRACKET .TAPA	1	1	1	1	
9	93210-16275	.O-RING .ANILLO O	1	1	1	1	

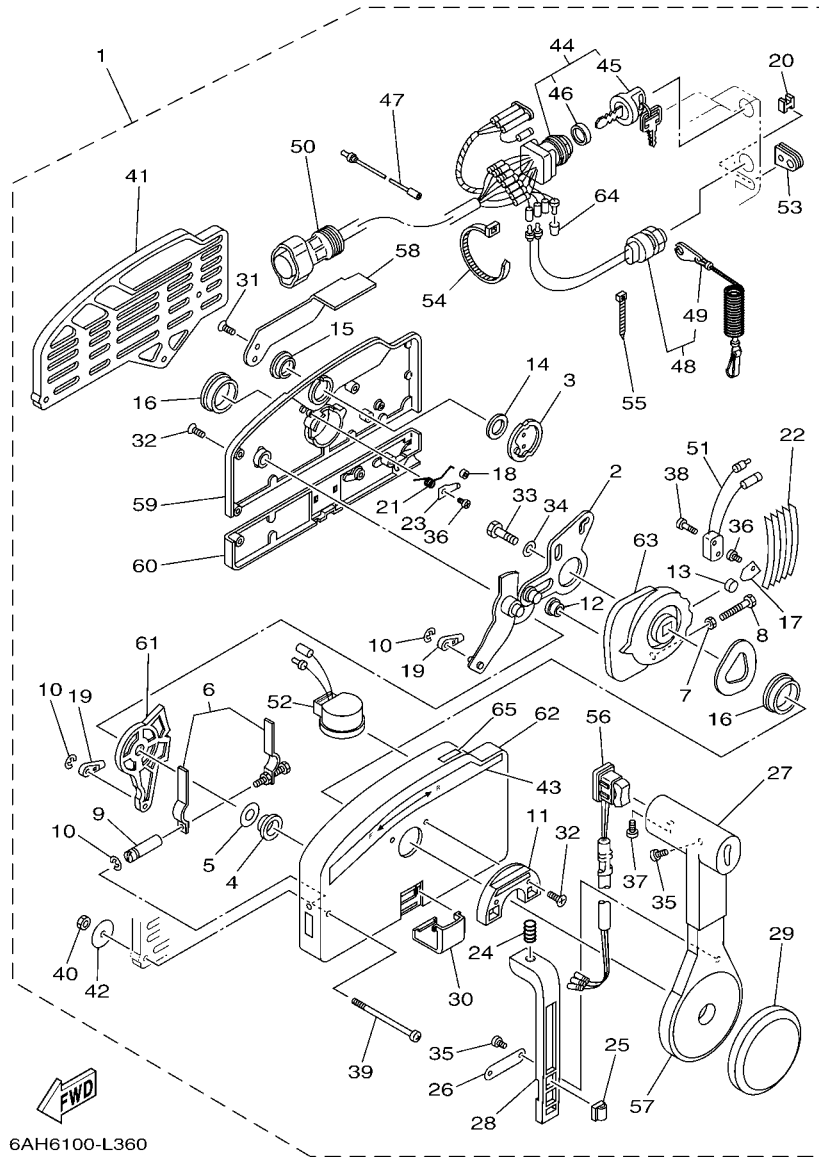

6AH6100-L360

FIG. 34 REMOTE CONTROL ASSY CONTROL REMOTO COMPL

REF. NO.	PART NO. CODIGO Nº	DESCRIPTION DESCRIPCION	6D66	6D76	6D86	6D96	REMARKS OBSERVACIONES
1	703-48205-A6	REMOTE CONTROL ASSY (10P) REMOTO CONTROL COMPL. (10P)	1	1	1	1	AP FOR CAR AP FOR CAR
	703-48205-1A	REMOTE CONTROL ASSY (10P) REMOTO CONTROL COMPL. (10P)		1			AP FOR CHN AP FOR CHN
	703-48207-1A	REMOTE CONTROL ASSY (10P) REMOTO CONTROL COMPL. (10P)			1		AP FOR BRA AP FOR BRA
2	703-48261-01	.ARM, THROTTLE .BRAZO ACELERADOR	1	1	1	1	
3	703-48153-00	.SHAFT, FREE ACCEL. .EJE	1	1	1	1	
4	703-48235-00	.BUSHING .BUJE	1	1	1	1	
5	703-48268-00	.SPACER .ESPACIADOR 3	1	1	1	1	
6	703-48264-00	.FRICTION, THROTTLE .FRICCION DE ACELERADOR	1	1	1	1	
7	95380-05600	.NUT .TUERCA	1	1	1	1	
8	97380-05025	.BOLT .TORNILLO HEXAGONAL	1	1	1	1	
9	703-48265-00	.SHAFT, FRICTION .EJE FRICCION	1	1	1	1	
10	93430-06024	.CIRCLIP .SEGURO	3	3	3	3	
11	703-48245-00	.PLATE, LOCK .PLACA CERRADURA	1	1	1	1	
12	703-48252-00	.ROLLER, CAM .RODILLO LEVA	1	1	1	1	
13	701-48248-00	.ROLLER, FREE ACCEL. .RODILLO ACELERADOR LIBRE	1	1	1	1	
14	703-48198-00	.WASHER, WAVE .RONDANA ONDULADA 3	1	1	1	1	
15	703-48243-00	.BUSHING .BUJE 3	1	1	1	1	
16	703-48236-00	.BUSHING 1 .BUJE	2	2	2	2	
17	703-48189-00	.RETAINER .RETENEDOR	1	1	1	1	
18	703-48234-00	.ROLLER, DETENT .RODILLO	1	1	1	1	
19	703-48345-01	.CABLE END, REMOTE CONTROL 2 .TERMINAL CABLE DE CONTROL REMO	2	2	2	2	
20	703-48358-00	.ANCHOR, CABLE .ABRAZADERA CABLE	1	1	1	1	
21	703-48244-00	.SPRING, FREE ACCEL. .RESORTE ACELERADOR LIBRE	1	1	1	1	
22	703-48238-00	.SPRING, DETENT .RESORTE	5	5	5	5	
23	703-48246-00	.SPACER .ESPACIADOR	1	1	1	1	
24	703-48227-00	.SPRING, NEUTRAL LOCK .RESORTE DE SEGURO	1	1	1	1	
25	703-82594-00	.CLAMP .GRAMPA	1	1	1	1	WITH PT/T SW. WITH PT/T SW.

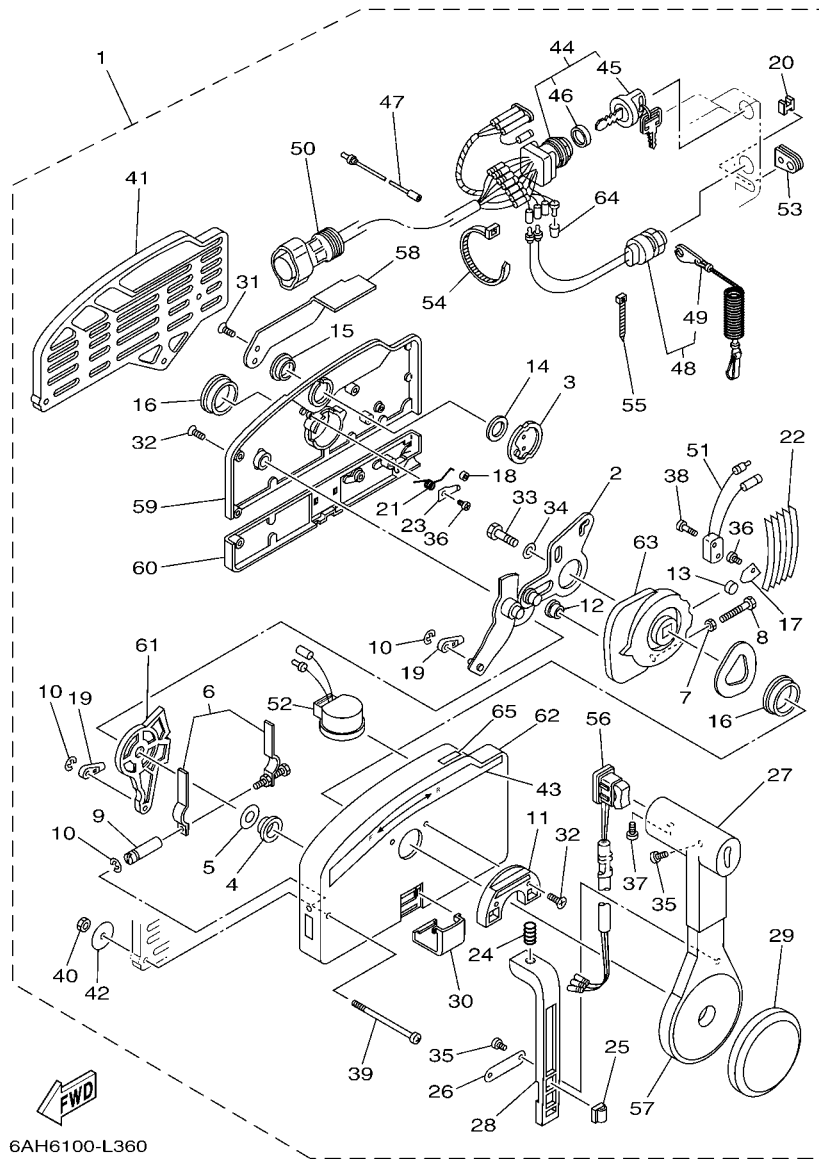

6AH6100-L360

FIG. 34 REMOTE CONTROL ASSY CONTROL REMOTO COMPL

REF. NO.	PART NO. CODIGO Nº	DESCRIPTION DESCRIPCION	6D66	6D76	6D86	6D96	REMARKS OBSERVACIONES
26	703-48226-00	.PLATE, STOPPER .PLACA RETEN	1	1	1	1	
27	703-48222-00	.GRIP, CONTROL LEVER .MANGO DE PALANCA CONTROL	1	1	1	1	SINGLE SINGLE
28	703-48223-00	.LOCK, NEUTRAL .CERRADURA NEUTRO	1	1	1	1	
29	703-48225-00	.COVER .CUBIERTA	1	1	1	1	
30	703-48219-00	.COVER, LEAD .CUBIERTA	1	1	1	1	
31	703-48281-00	.SCREW .TORNILLO 1	2	2	2	2	
32	703-48282-00	.SCREW .TORNILLO 2	7	7	7	7	
33	97380-08030	.BOLT .TORNILLO HEXAGONAL	1	1	1	1	
34	92990-08600	.WASHER, PLATE .ARANDELA PLANA	1	1	1	1	
35	98580-04010	.SCREW, PAN HEAD .TORNILLO DE CABEZA CRUZADA	3	3	3	3	
36	98580-04006	.SCREW, PAN HEAD .TORNILLO DE CABEZA CRUZADA	2	2	2	2	
37	98580-05010	.SCREW, PAN HEAD .TORNILLO DE CABEZA CRUZADA	1	1	1	1	
38	98580-03015	.SCREW, PAN HEAD .TORNILLO DE CABEZA CRUZADA	2	2	2	2	
39	703-48291-10	.SCREW (M6) .TORNILLO (M6)	3	3	3	3	
40	95380-06600	.NUT, HEXAGON .TUERCA	3	3	3	3	
41	703-48293-10	.SPACER, REMOTE CONTROL .ESPACIADOR	1	1	1	1	SINGLE SINGLE
42	701-48287-00	.WASHER .ARANDELA	3	3	3	3	
43	703-48215-00	.GRAPHIC .CALCOMANIA 1	1	1	1	1	
44	703-82510-12	.MAIN SWITCH ASSY .CONJUNTO DE LLAVE IGNICION	1	1	1	1	FOR CAR FOR CAR
	703-82510-43	.MAIN SWITCH ASSY .CONJUNTO DE LLAVE IGNICION		1	1		FOR CHN,BRA FOR CHN,BRA
45	676-82577-00	..CAP, KEY ..TAPA	1	1	1	1	FOR 703-82510-12 FOR 703-82510-12
	703-82577-00	..CAP, KEY ..TAPA		1	1		FOR 703-82510-43 FOR 703-82510-43
46	703-82532-00	..CAP ..TAPA	1	1	1	1	FOR 703-82510-12 FOR 703-82510-12
	6K1-82532-00	..CAP ..TAPA		1	1		FOR 703-82510-43 FOR 703-82510-43
47	703-82531-00	.WIRE, LEAD (L70) .CABLE CONDUCTOR (L70)	1	1	1	1	
48	688-82575-01	.ENGINE STOP SWITCH ASSY .INTERRUPTOR DE PARADA COMPL	1	1	1	1	
49	682-82556-00	..LANYARD, STOP SWITCH ..CORDON DE INTERRUPTOR PARADA	1	1	1	1	

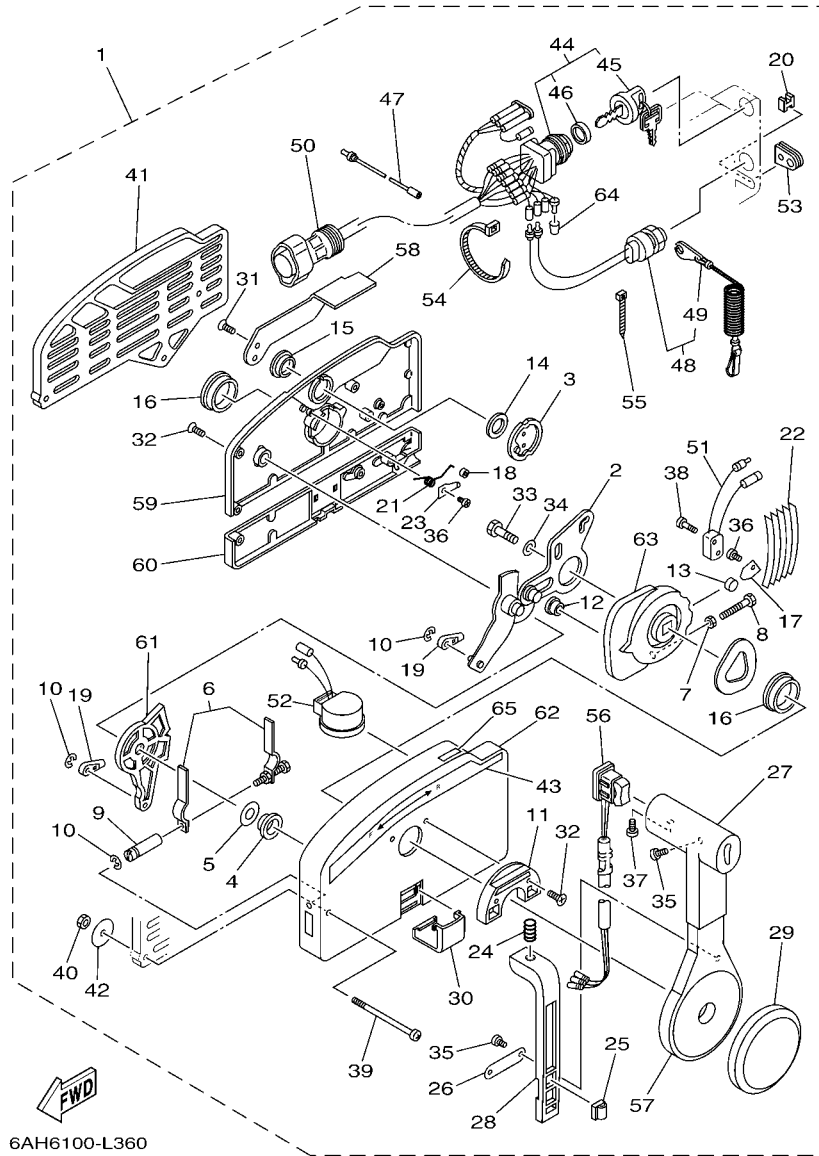
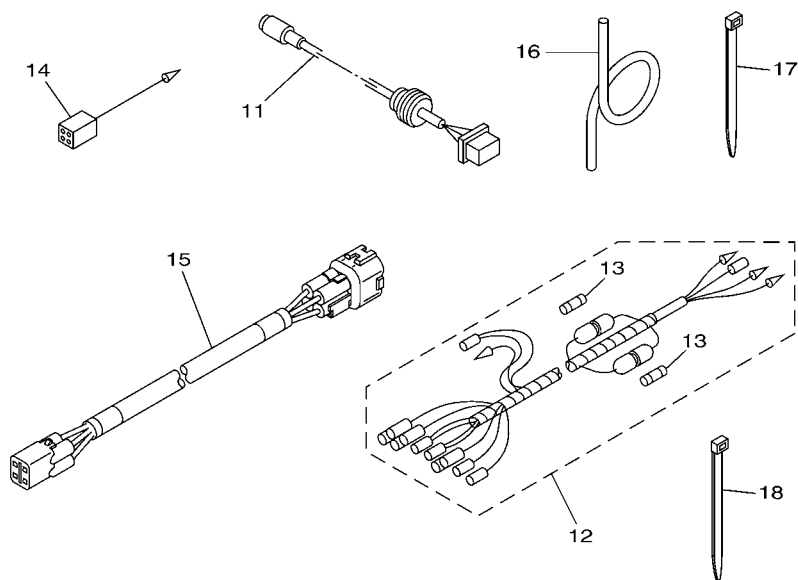
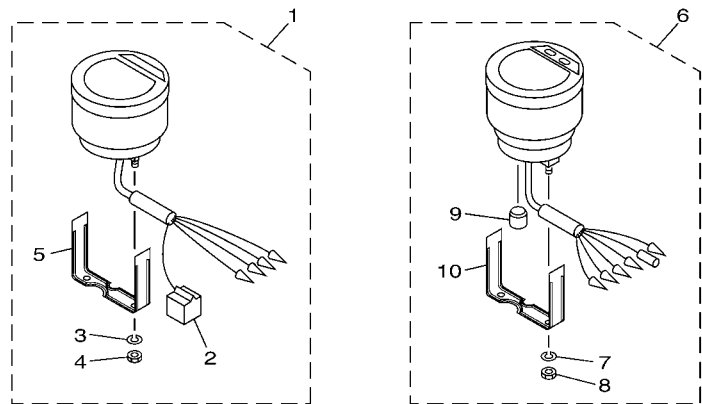

FIG. 34 REMOTE CONTROL ASSY CONTROL REMOTO COMPL

REF. NO.	PART NO. CODIGO Nº	DESCRIPTION DESCRIPCION	6D66	6D76	6D86	6D96	REMARKS OBSERVACIONES
50	688-8258A-20	.EXTENSION, WIRE HARNESS (4.9M) .EXTENSION, ARNES DE CABLES (4.	1	1	1	1	(10P) (10P)
51	703-82540-00	.NEUTRAL SWITCH ASSY .INTERRUPTOR NEUTRAL COMPL	1	1	1	1	
52	703-83383-B0	.BUZZER .ZUMBADOR	1	1	1	1	FOR CAR FOR CAR
	703-83383-11	.BUZZER .ZUMBADOR			1	1	FOR CHN,BRA FOR CHN,BRA
53	703-48284-00	.GROMMET .TAPON	1	1	1	1	FOR CAR,CHN FOR CAR,CHN
	703-48284-10	.GROMMET .TAPON				1	FOR BRA FOR BRA
54	703-82591-00	.BAND .BANDA	1	1	1	1	FOR CAR,CHN FOR CAR,CHN
	703-82591-00	.BAND .BANDA				3	FOR BRA FOR BRA
55	703-82592-00	.BAND .BANDA	1	1	1	1	
56	703-82563-02	.TRIM & TILT SWITCH ASSY .INTERRUPTOR DE INCLINACION	1	1	1	1	FOR CAR,CHN FOR CAR,CHN
	703-82563-12	.TRIM & TILT SWITCH ASSY .INTERRUPTOR DE INCLINACION				1	FOR BRA FOR BRA
57	703-48221-00	.LEVER, CONTROL .PALANCA CONTROL	1	1	1	1	
58	703-48152-00	.KNOB, FREE ACCEL. .PERILLA	1	1	1	1	
59	703-48212-00	.BACK PLATE 1 .PLACA TRASERA 1	1	1	1	1	
60	703-48213-00	.BACK PLATE 2 .PLACA TRASERA 2	1	1	1	1	
61	703-48271-00	.ARM, SHIFT .BRAZO CAMBIADOR	1	1	1	1	
62	703-48211-02	.HOUSING,1 .CAJA	1	1	1	1	
63	703-48232-00	.GEAR .ENGRANAJE 1	1	1	1	1	
64	703-82542-00	.CAP .TAPA	1	1	1	1	FOR CAR FOR CAR
65	703-48218-00	.GRAPHIC .CALCAMONIA	1	1	1	1	FOR CAR FOR CAR



6D64200-G340

FIG. 35 METER

MEDIDOR

REF. NO.	PART NO. CODIGO Nº	DESCRIPTION DESCRIPCION	6D66	6D76	6D88	6D98	REMARKS OBSERVACIONES
1	6Y5-8350T-90	DIGITAL TACHOMETER ASSY TACOMETRO DIGITAL COMPLETO		1	1		AP CHN,BRA AP CHN,BRA
2	9E450-04533	.CONNECTOR .CONECTOR		1	1		F-4-W F-4-W
3	92990-04100	.WASHER, SPRING .ARANDELA PLANA		2	2		
4	95380-04600	.NUT .TUERCA		2	2		
5	6Y5-8355X-T1	.BRACKET, METER 1 .SOSTEN		1	1		
6	6Y5-83570-S5	SPEEDOMETER ASSY VELOCIMETRO COMPLETO		1	1		AP CHN-L,BRA AP CHN-L,BRA
7	92990-04100	.WASHER, SPRING .ARANDELA PLANA		2	2		
8	95380-04600	.NUT .TUERCA		2	2		
9	6Y5-83533-T2	.GROMMET .ANILLO PROTECTOR		1	1		
10	6Y5-8355X-T1	.BRACKET, METER 1 .SOSTEN		1	1		
11	6Y5-87122-S0	CORD ASSY 1 CABLE COMPLETA 1		1	1		AP CHN-L,BRA AP CHN-L,BRA
12	6Y5-83553-M0	WIRE, LEAD (L=2.5M) CABLE CONDUCTOR (L=2.5M)		1	1		AP CHN-L,BRA AP CHN-L,BRA
	6Y5-83553-00	WIRE, LEAD (L=2.5M) CABLE CONDUCTOR (L=2.5M)		1			AP CHN-X AP CHN-X
13	1E6-82151-00	.FUSE (10A) .FUSIBLE (10A)		2	2		FOR 6Y5-83553-M0 FOR 6Y5-83553-M0
	1E6-82151-00	.FUSE (10A) .FUSIBLE (10A)		1			FOR 6Y5-83553-00 FOR 6Y5-83553-00
14	6Y5-82117-00	WIRE, LEAD (BLACK) (L300) CABLE, CONDUCTOR (NEGRO)		1			AP CHN-L AP CHN-L
15	6Y5-83653-30	WIRE, LEAD (L=8.0M) CABLE CONDUCTOR (L=8.0M)		1	1		AP CHN,BRA 4P,8M AP CHN,BRA 4P,8M
16	6Y5-83557-10	TUBE (8M) TUBO (8M)		1	1		AP CHN-L,BRA AP CHN-L,BRA
17	90465-11M10	CLAMP BRIDA		2	2		AP CHN-L,BRA AP CHN-L,BRA
18	90465-13M18	CLAMP BRIDA			10		AP BRA AP BRA

FIG. 36 OPTIONAL PARTS 2

PARTES OPCIONALES 2

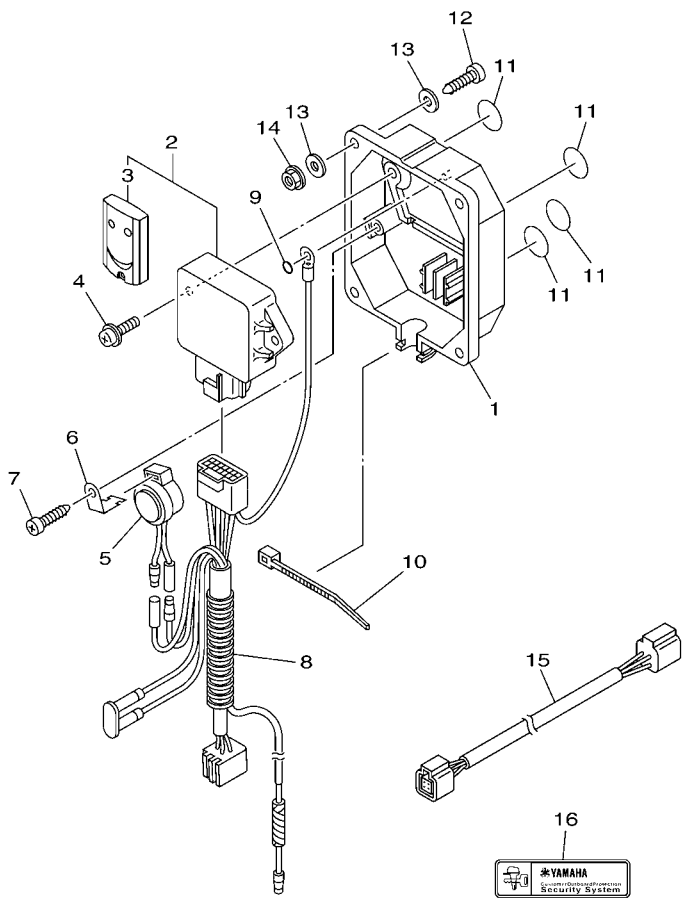

6CJ1100-K370

REF. NO.	PART NO. CODIGO Nº	DESCRIPTION DESCRIPCION	6D66	6D76	6D86	6D96	REMARKS OBSERVACIONES
1	6Y8-86267-00	CASE COMPLETE 1 CAJA COMPLETA 1	1	1	1	1	FOR CAR ONLY FOR CAR ONLY
2	6Y8-86260-11	REMOTE CONTROL UNIT ASSY UNIDAD DE CONTROL REMOTO COMPL	1	1	1	1	FOR CAR ONLY FOR CAR ONLY
3	6AA-86261-21	.TRANSMITTER COMP .TRANSMISOR	2	2	2	2	
4	97980-06216	SCREW, WITH WASHER TORNILLO, CON ARANDELA	2	2	2	2	FOR CAR ONLY FOR CAR ONLY
5	6X4-83383-00	BUZZER ZUMBADOR	1	1	1	1	FOR CAR ONLY FOR CAR ONLY
6	6X4-83386-00	STAY, BUZZER TIRANTE DE ZUMBADOR	1	1	1	1	FOR CAR ONLY FOR CAR ONLY
7	97780-60620	SCREW, TAPPING TORNILLO DE CABEZA DE CONO ACH	1	1	1	1	FOR CAR ONLY FOR CAR ONLY
8	6Y8-82509-10	WIRE, SUB LEAD CABLE SUBCONDUCTOR	1	1	1	1	FOR CAR ONLY FOR CAR ONLY
9	93210-04279	O-RING ANILLO O	1	1	1	1	FOR CAR ONLY FOR CAR ONLY
10	90465-11M10	CLAMP BRIDA	1	1	1	1	FOR CAR ONLY FOR CAR ONLY
11	6Y8-8454G-00	PATCH 1 PARCHE 1	4	4	4	4	FOR CAR ONLY FOR CAR ONLY
12	90167-06M00	SCREW, TAPPING TORNILLO DE ROSCA HEMBRA	4	4	4	4	UR FOR CAR ONLY UR FOR CAR ONLY
	97880-06035	SCREW, PAN HEAD TORNILLO DE CABEZA CON PLANA	4	4	4	4	UR FOR CAR ONLY UR FOR CAR ONLY
13	90201-06M30	WASHER, PLATE ARANDELA PLANA	8	8	8	8	FOR CAR ONLY FOR CAR ONLY
14	95780-06300	NUT, FLANGE TUERCA	4	4	4	4	FOR CAR ONLY FOR CAR ONLY
15	6Y8-82521-11	2FT PIGTAIL BUS CABLE CONDUCTOR	1	1	1	1	FOR CAR ONLY FOR CAR ONLY
16	6Y8-48277-00	STICKER 1 ETIQUETTE 1	4	4	4	4	FOR CAR ONLY FOR CAR ONLY

FIG. 37 REPAIR KIT 1

ESTUCHE REPARATION 1

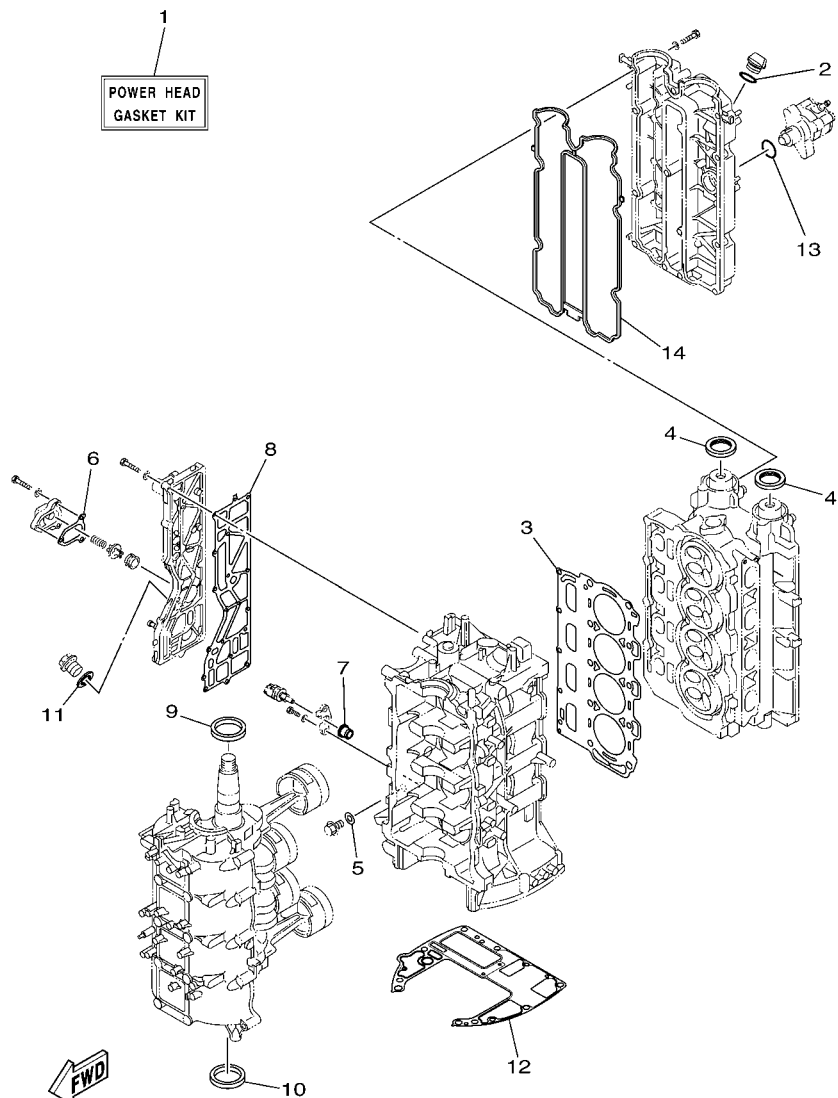

6D67110-K320

REF. NO.	PART NO. CODIGO Nº	DESCRIPTION DESCRIPCION	6D66	6D76	6D86	6D96	REMARKS OBSERVACIONES
1	6D8-W0001-02	POWER HEAD GASKET KIT JUEGO DE EMPAQUE DE MOTOR	1	1	1	1	
2	93210-24M79	.O-RING .ANILLO O	1	1	1	1	
3	67F-11181-03	.GASKET, CYLINDER HEAD 1 .JUNTA, DE CULATA 1	1	1	1	1	
4	93102-38008	.OIL SEAL .SELLO ACEITE	2	2	2	2	
5	90430-14115	.GASKET .JUNTA	1	1	1	1	
6	67F-12435-A0	.GASKET .EMPAQUE	1	1	1	1	
7	68V-85753-00	.GASKET, SENDER UNIT .EMPAQUE DE UNIDAD TRANSMISORA	1	1	1	1	
8	67F-41114-A2	.GASKET, EXHAUST OUTER COVER .EMPAQUE	1	1	1	1	
9	93102-48008	.OIL SEAL .SELLO ACEITE	1	1	1	1	
10	93101-48001	.OIL SEAL .SELLO ACEITE	1	1	1	1	
11	90430-18130	.GASKET .JUNTA	1	1	1	1	
12	68V-11351-00	.GASKET, CYLINDER .JUNTA, DE CILINDRO	1	1	1	1	
13	93210-30682	.O-RING .ANILLO O	1	1	1	1	
14	6D8-11356-01	.SEAL, CYLINDER 2 .RETEN ACEITE CILINDRO 2	1	1	1	1	

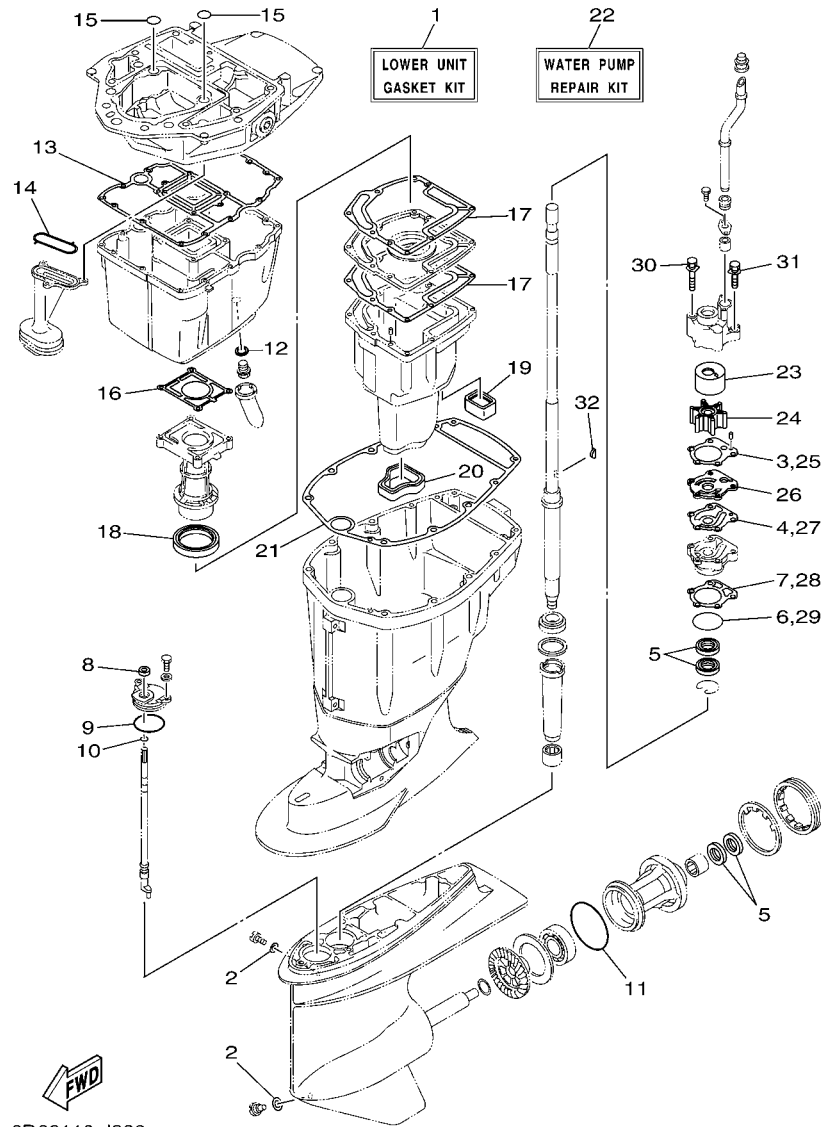

6D66110-J320

FIG. 38 REPAIR KIT 2

ESTUCHE REPARACION 2

REF. NO.	PART NO. CODIGO Nº	DESCRIPTION DESCRIPCION					REMARKS OBSERVACIONES
			6D66	6D76	6D88	6D98	
1	67F-W0001-21	LOWER UNIT GASKET KIT JUEGO DE EMPAQUE UNIDAD INFER.	1	1	1	1	
2	90430-08020	.GASKET .JUNTA	2	2	2	2	
3	688-44315-A0	.GASKET, WATER PUMP .EMPAQUE	1	1	1	1	
4	688-44324-A0	.GASKET, CARTRIDGE .EMPAQUE	1	1	1	1	
5	93101-25M03	.OIL SEAL .SELLO ACEITE	4	4	4	4	
6	93210-46044	.O-RING .ANILLO O	1	1	1	1	
7	688-44316-A0	.GASKET, WATER PUMP .EMPAQUE	1	1	1	1	
8	93106-09014	.OIL SEAL .SELLO ACEITE	1	1	1	1	
9	93210-49046	.O-RING .ANILLO O	1	1	1	1	
10	93210-07003	.O-RING .ANILLO O	1	1	1	1	
11	93210-86M39	.O-RING .ANILLO O	1	1	1	1	
12	90430-14M09	.GASKET .JUNTA	1	1	1	1	
13	68V-15312-00	.GASKET, OIL PAN .EMPAQ BANDEJA DE ACEITE	1	1	1	1	
14	67F-13415-00	.SEAL, OIL STRAINER .SELLO COLADOR ACEITE	1	1	1	1	
15	93210-19MJ1	.O-RING .ANILLO O	2	2	2	2	
16	67F-41133-A1	.GASKET, EXHAUST MANIFOLD 1 .EMPAQUE ESCAPE MULTIPLE	1	1	1	1	
17	67F-41134-A0	.GASKET, EXHAUST MANIFOLD .EMPAQUE	2	2	2	2	
18	67F-41138-00	.SEAL, EXT. 1 .SELLO, ESCAPE 1	1	1	1	1	
19	67F-45127-00	.SEAL .SELLO DE GOMA	1	1	1	1	
20	67F-45123-00	.GASKET, MUFFLER .EMPAQUE SILENCIADOR	1	1	1	1	
21	67F-45113-00	.GASKET, UPPER CASING .EMPAQUE	1	1	1	1	
22	67F-W0078-00	WATER PUMP REPAIR KIT ESTUCHE REPARACION BOMBA AGUA	1	1	1	1	
23	67F-44322-00	.INSERT, CARTRIDGE .CARTUCHO	1	1	1	1	
24	67F-44352-00	.IMPELLER .IMPULSOR	1	1	1	1	
25	688-44315-A0	.GASKET, WATER PUMP .EMPAQUE	1	1	1	1	
26	67F-44323-00	.OUTER PLATE, CARTRIDGE .PLACA EXTERIOR DEL CARTUCHO	1	1	1	1	
27	688-44324-A0	.GASKET, CARTRIDGE .EMPAQUE	1	1	1	1	

FIG. 38 REPAIR KIT 2

ESTUCHE REPARATION 2

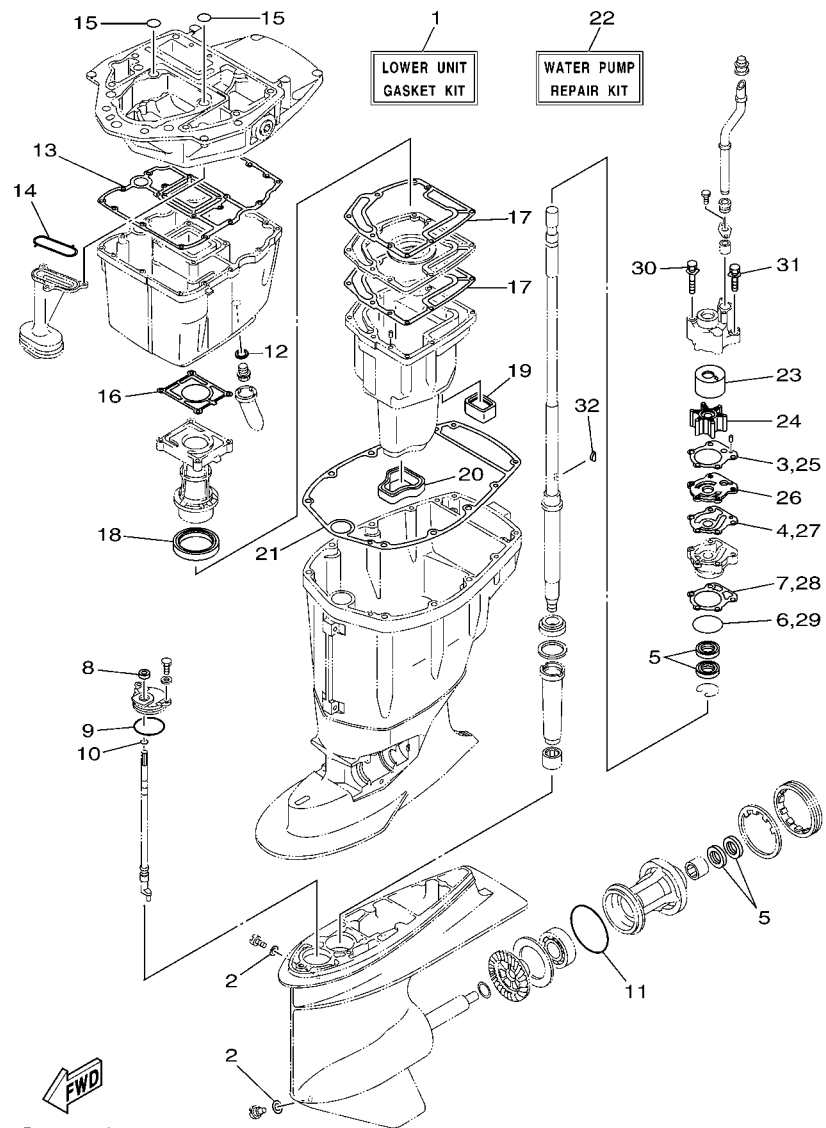

REF. NO.	PART NO. CODIGO Nº	DESCRIPTION DESCRIPCION	6D66	6D76	6D86	6D96	REMARKS OBSERVACIONES
28	688-44316-A0	.GASKET, WATER PUMP .EMPAQUE	1	1	1	1	
29	93210-46044	.O-RING .ANILLO O	1	1	1	1	
30	90119-08M87	.BOLT, WITH WASHER .TORNILLO CON ARANDELA	2	2	2	2	
31	90119-08M13	.BOLT, WITH WASHER .TORNILLO CON ARANDELA	2	2	2	2	
32	90280-04M04	.KEY, WOODRUFF .CUNA WOODRUFF	1	1	1	1	

NUMERICAL INDEX
INDICE NUMERICO

PART NO. CODIGO N°	REF. NO.	PART NO. CODIGO N°	REF. NO.	PART NO. CODIGO N°	REF. NO.	PART NO. CODIGO N°	REF. NO.	PART NO. CODIGO N°	REF. NO.	PART NO. CODIGO N°	REF. NO.
6D8-11110-13-9S	4 - 2	6D8-12153-10	5 - 9	67F-13149-00	27 - 21	6D8-14200-00	6 - 1	6Y2-24305-06	12 - 11	69J-24502-00	8 - 14
62Y-11119-00	2 - 8	6D8-12153-20	5 - 9	6D8-13161-00	6 - 13	6C5-14225-00	9 - 25		30 - 13	6D8-24519-00	11 - 10
67F-11133-10	4 - 3	6D8-12153-30	5 - 9	67F-13300-10	27 - 12	6C5-14251-00	10 - 12	6Y2-24306-45	12 - 6	6D8-2451B-00	10 - 20
67F-11168-00	4 - 19	6D8-12153-40	5 - 9	67F-13314-02	27 - 13	6D8-14291-00	7 - 5		30 - 8	6D8-2451B-20	10 - 20
67F-11181-03	4 - 14	6D8-12153-50	5 - 9	6D8-13329-00	27 - 15	6D8-14292-00	7 - 9	6Y2-24307-50	12 - 1	6D8-24560-00	11 - 5
	37 - 3	6D8-12153-60	5 - 9	67F-13338-00	27 - 23	6C5-14386-00	9 - 5	6D8-24311-00	11 - 16	6D8-24562-00	11 - 8
6D8-11191-01-9S	4 - 18	6D8-12153-70	5 - 9	67F-13339-00	27 - 22	6C5-14397-00	6 - 11	6D8-24311-10	11 - 16	6D8-24563-00	11 - 6
67F-11192-01	4 - 26	6D8-12153-80	5 - 9	67F-13411-00	27 - 8		9 - 14	67F-24312-00	19 - 43	6D8-24564-00	11 - 7
69J-11301-00	2 - 34	6D8-12153-90	5 - 9	67F-13415-00	27 - 11	6D6-14440-00	7 - 14	6D8-24314-01	8 - 6	6D8-24566-00	11 - 12
	4 - 8	6D8-12153-A0	5 - 9		38 - 14	6D8-14440-01	7 - 14	6D8-24315-00	8 - 9	6C5-24592-00	9 - 10
6E5-11325-00	2 - 16	6D8-12153-B0	5 - 9	6D8-13428-01	8 - 3	6D9-14440-01	7 - 14	61A-24316-00	2 - 26	6YJ-24610-01	30 - 2
67F-11325-01	2 - 35	6D8-12153-C0	5 - 9	67F-13434-20	1 - 19	6C5-14446-00	6 - 14	6D8-24316-00	8 - 15	6YL-24610-10	31 - 2
	4 - 9	6D8-12153-D0	5 - 9	68V-13437-42	13 - 22	6C5-14496-00	6 - 9	6D8-24317-01	8 - 20	6YL-24629-00	31 - 4
67F-11328-00	2 - 36	6D8-12153-E0	5 - 9	68V-13437-62	13 - 22	6C5-14546-10	9 - 4	6C5-24321-00	10 - 3	6YL-24641-10	31 - 3
	4 - 10	6D8-12153-F0	5 - 9	5GH-13440-00	2 - 44	6C5-14567-00	9 - 15	6C5-24321-20	10 - 3	67F-28100-01	11 - 32
68V-11351-00	2 - 43	6D8-12153-G0	5 - 9	67F-13473-01	27 - 14	67F-14711-00-CA	26 - 9	6C5-24322-00	10 - 4	67F-28100-10	11 - 32
	37 - 12	6D8-12153-H0	5 - 9	67F-13495-00	27 - 16	6D8-14960-10	9 - 12	6C5-24322-20	10 - 4	67F-2812A-00	15 - 29
6D8-11356-01	4 - 23	6D8-12153-J0	5 - 9	6D8-13542-01	10 - 2	6C5-14984-00	9 - 23	6C5-24323-00	10 - 5	6D8-41113-40-9S	2 - 12
	37 - 14	6D8-12153-K0	5 - 9	6C5-13545-00	10 - 18	6C5-14985-00	9 - 3	6D8-24324-01	10 - 6	67F-41114-A2	2 - 18
676-11372-00	2 - 13	6D8-12153-L0	5 - 9	6D8-13546-01	10 - 1	6D8-15100-01	2 - 2	6D8-24325-10	10 - 7		37 - 8
6D8-11411-00	3 - 1	6D8-12153-M0	5 - 9	6D8-13557-00	6 - 4	67F-15142-00	2 - 11	6Y1-24329-00	30 - 5	67F-41131-01-CA	26 - 5
6D8-11416-00	3 - 2	6D8-12153-N0	5 - 9	6C5-13577-00	10 - 10	67F-15311-03-CA	27 - 1	6E5-24351-51	12 - 3	67F-41133-A1	26 - 6
6D8-11416-10	3 - 2	6D8-12153-P0	5 - 9	6C5-13593-00	9 - 20	68V-15312-00	27 - 7		12 - 8		38 - 16
6D8-11416-20	3 - 2	6D8-12153-R0	5 - 9	67F-13631-03	27 - 20		38 - 13		30 - 10	67F-41134-A0	26 - 15
6D8-11417-00	3 - 3	6D8-12153-S0	5 - 9	6D8-13641-00	6 - 2	63P-15316-00	27 - 2	6Y2-24360-60	12 - 5		38 - 17
6D8-11417-10	3 - 3	6D8-12153-T0	5 - 9	6D8-13645-00	6 - 3	6D8-15362-00	27 - 28		12 - 10	6D8-41137-00-CA	26 - 1
6D8-11417-20	3 - 3	6D8-12153-U0	5 - 9	6C5-13716-00	9 - 22	6G8-15363-00	4 - 33		30 - 12	67F-41138-00	26 - 17
6D8-11417-30	3 - 3	6D8-12153-V0	5 - 9	6C5-13739-00	10 - 21	6D8-15373-00	7 - 19	6YK-24360-71	31 - 5		38 - 18
6D8-11418-00	3 - 4	6D8-12171-00	5 - 10	6D8-13750-00	6 - 5	6C5-21337-10	9 - 24	68V-24374-00	11 - 23	682-41237-00	20 - 43
6D8-11418-10	3 - 4	6D9-12171-00	5 - 10	6D8-13761-00	6 - 15	6D8-2134X-00	8 - 25	6R3-24377-00	11 - 2	6D8-41237-00	20 - 42
6D8-11418-20	3 - 4	6D8-12181-00	5 - 11	67F-13769-00	27 - 18	6C5-21841-00	10 - 11	6R3-24377-10	11 - 2	6D8-42154-00	20 - 25
6D8-11536-00	5 - 21	6D9-12411-00	4 - 28	6C5-13781-00	9 - 21	1UF-22434-00	24 - 41	688-24378-00	2 - 25	6D8-42157-00	20 - 34
67F-11537-00	5 - 13	67F-12411-01	4 - 28	6D8-13782-00	7 - 13	67F-22435-00	24 - 12	6C5-24379-00	10 - 17	68V-42171-00	20 - 35
67F-11590-00	5 - 16	67F-12412-00	4 - 29	6C5-13906-01	9 - 9	67F-22471-01	24 - 37	6C5-24387-00	10 - 14	67F-42510-11-8D	22 - 8
67F-11595-00	5 - 19	68V-12413-00-9S	4 - 30	6C5-13907-00	9 - 17	6D8-2413X-01	8 - 19	6D8-24410-10	11 - 17	6D8-42541-00	2 - 20
6D8-11603-01	3 - 7	6G5-12416-00	2 - 28	6C5-13910-10	9 - 16	68V-24149-00	11 - 27	68V-24411-00	11 - 22	6D6-42610-20	1 - 1
6D8-11604-01	3 - 7	67F-12435-A0	2 - 32	67F-13914-00	27 - 19	6YJ-24167-00	30 - 7	68V-24412-00	11 - 18	6D7-42610-20	1 - 1
6D8-11656-00	3 - 8		37 - 6	6C5-13915-00	9 - 19	69J-24170-00	8 - 8	68V-24413-10	11 - 24	6D9-42610-20	1 - 1
6D8-11656-10	3 - 8	67F-1243A-00	2 - 40	6D8-13974-00	10 - 15	6D8-2417H-01	8 - 11	6D8-24414-00	11 - 25	6D8-42610-30	1 - 1
6D8-11656-20	3 - 8	67F-1246A-01-9S	2 - 31	6C5-1410B-00	6 - 16	69J-2419A-01	8 - 22	6C5-2441R-10	9 - 6	67F-42613-00-8D	1 - 10
6D8-11656-30	3 - 8	67F-12535-01	19 - 33	6C5-14127-10	9 - 18	6YJ-24201-00	30 - 1	6C5-2441T-10	9 - 7	67F-42615-00	1 - 13
6D8-12111-00	5 - 1	68T-12572-00	19 - 32	6D8-14148-00	10 - 13	6YJ-24201-10	30 - 1	68V-24423-00	11 - 21	61N-42628-00	1 - 12
6D8-12113-00	5 - 4	6R3-12581-00	19 - 40	6D8-14148-20	10 - 13	6YK-24201-41	31 - 1	68V-24444-00	11 - 26	67F-42628-00	1 - 18
6D8-12116-00	5 - 3	6R3-12582-00	19 - 41	6BG-14149-00	10 - 8	6C5-24251-00	10 - 19	6C5-24444-00	10 - 9	67F-42647-00	1 - 2
26H-12117-00	5 - 5	6R3-12583-00	19 - 42	6D8-14180-21	9 - 1	6YJ-24260-00	30 - 3	68V-24452-00	11 - 31	67F-42649-00	1 - 8
4G0-12118-00	5 - 6	6D8-13105-01	6 - 10	6D8-14180-40	9 - 1	6Y1-24260-12	30 - 3	6C5-24453-00	9 - 8	68V-42652-00	1 - 5
6D8-12121-00	5 - 2	67F-13119-01	27 - 17	6D8-14182-10	9 - 2	6Y1-24268-00	30 - 6	68V-24454-00	11 - 19	67F-42662-00	1 - 9
6D8-12153-00	5 - 9	63P-13131-00	11 - 20	6C5-14191-00	9 - 13	6YK-24305-00	31 - 6	6D8-24469-00	11 - 9	60C-42677-10	1 - 14

NUMERICAL INDEX
INDICE NUMERICO

PART NO. CODIGO N°	REF. NO.	PART NO. CODIGO N°	REF. NO.	PART NO. CODIGO N°	REF. NO.	PART NO. CODIGO N°	REF. NO.	PART NO. CODIGO N°	REF. NO.	PART NO. CODIGO N°	REF. NO.
6D6-42677-10	1 - 14	67F-43810-01	24 - 2	6H1-43872-10	24 - 16	688-44324-A0	38 - 27	67F-45501-30	28 - 10	703-48198-00	34 - 14
6D7-42677-10	1 - 14	6H1-43812-00	24 - 13	62X-43875-00	24 - 42	6D8-44341-01-CA	28 - 30	688-45536-01	28 - 14	703-48205-1A	33 - 1
6D8-42677-20	1 - 14	67F-43816-00	24 - 29	67F-43875-00	24 - 24	67F-44352-00	28 - 25	6D9-45551-00	28 - 11		34 - 1
6D6-42678-20	1 - 15	6C5-43816-00	24 - 46	6H1-43875-00	24 - 87		38 - 24	67F-45560-00	28 - 53	703-48205-A6	33 - 1
6D7-42678-20	1 - 15	6D6-43817-00	24 - 44	6D8-43878-00	24 - 71	6D8-44361-00	29 - 2	688-45567-01	28 - 56		34 - 1
6D9-42678-20	1 - 15	67F-43818-00	21 - 34	62Y-4387G-00	24 - 72	6D8-44361-10	29 - 2	688-45567-10	28 - 56	703-48207-1A	33 - 1
6D8-42678-30	1 - 15	67F-4381B-00	24 - 38	6C6-4387G-00	24 - 56	67F-44365-00	29 - 4	688-45567-20	28 - 56		34 - 1
6D6-42681-00	1 - 17	6D8-4381G-00	24 - 84	6D8-43880-01	24 - 95	663-44366-00	28 - 21	688-45567-30	28 - 56	703-48211-02	34 - 62
6D8-42710-00-8D	19 - 1	67F-4381J-00	24 - 36		25 - 1	663-44367-00	29 - 1	688-45567-40	28 - 56	703-48212-00	34 - 59
648-42715-00	20 - 22	6C5-4381K-00	24 - 62	6D8-43881-01	25 - 12	69J-44391-00	8 - 18	688-45567-50	28 - 56	703-48213-00	34 - 60
61A-42716-00	19 - 45	67F-43821-00	24 - 14	6H1-43883-00	24 - 51	6BL-44391-00	19 - 25	688-45567-60	28 - 56	703-48215-00	34 - 43
67F-42717-00	19 - 27	6H1-43829-00	24 - 90	65W-43888-00	24 - 93	67F-44514-01	22 - 16	6D9-45571-00	28 - 57	703-48218-00	34 - 65
6D8-42717-00	19 - 21	6C6-4382E-00	24 - 53	67F-4388A-00	24 - 33	67F-44526-00	22 - 19	67F-45576-00	28 - 65	703-48219-00	34 - 30
67F-42724-00	26 - 37	6C5-4382K-00	24 - 64	6C6-4388E-00	24 - 75	6H1-44526-00	21 - 41	688-45587-01	28 - 16	703-48221-00	34 - 57
68V-42725-00	19 - 19	6C5-4382L-00	24 - 65	6C6-4388F-00	24 - 76	67F-44533-00	22 - 22	688-45587-10	28 - 16	703-48222-00	34 - 27
6H1-42726-21	19 - 24	6D8-43830-00	24 - 49	6H1-43891-11	25 - 4	67F-44551-00-8D	22 - 14	688-45587-20	28 - 16	703-48223-00	34 - 28
6G1-42727-00	26 - 4	6D8-43831-00	24 - 91	6H1-43892-11	25 - 5	67F-44553-00-8D	22 - 33	688-45587-30	28 - 16	703-48225-00	34 - 29
67F-42738-00-8D	19 - 17	6C5-43841-00	24 - 82	67F-43893-00	24 - 23	67F-44555-00	22 - 24	688-45587-40	28 - 16	703-48226-00	34 - 26
67F-42741-01-8D	19 - 46	6C6-43841-00	24 - 50	6C5-43893-00	24 - 59	67F-44575-00	22 - 32	688-45587-50	28 - 16	703-48227-00	34 - 24
6H4-42748-00	19 - 26	6D8-43845-00	24 - 88	6C6-43893-00	24 - 61	67F-45111-11-8D	26 - 20	688-45587-60	28 - 16	703-48232-00	34 - 63
6D8-42756-02	19 - 20	62X-4384H-00	24 - 40	6C6-43894-00	24 - 52	67F-45113-00	26 - 28	67F-45611-01	28 - 60	703-48234-00	34 - 18
6AH-42794-40	19 - 52	6C5-43851-00	24 - 58	6C5-43895-00	24 - 66		38 - 21	6D8-45631-00	28 - 50	703-48235-00	34 - 4
6AH-42794-50	19 - 53	65W-43853-00	24 - 22	62X-43899-00	24 - 39	67F-45123-00	26 - 19	688-45633-00	28 - 52	703-48236-00	34 - 16
6AH-42794-70	19 - 52	6C6-43853-00	24 - 55	67F-43899-00	24 - 28		38 - 20	67F-45634-00	28 - 44	703-48238-00	34 - 22
67F-42815-00-8D	19 - 5	6C5-43854-00	24 - 67	69J-4389J-00	24 - 45	67F-45127-00	26 - 18	6H1-45635-00	28 - 46	703-48243-00	34 - 15
67F-42816-00-8D	19 - 6	6D8-43855-00	24 - 60		24 - 57		38 - 19	6H1-45668-00	28 - 45	703-48244-00	34 - 21
68V-42818-01	19 - 9	6D8-43856-00	24 - 63	6D8-44117-00-94	20 - 5	67F-45151-00	26 - 25	688-45930-02	29 - 25	703-48245-00	34 - 11
67F-42828-00-8D	19 - 7	67F-43857-00	24 - 35	67F-44118-00-94	20 - 18	67F-45155-00	26 - 27	688-45932-60	29 - 25	703-48246-00	34 - 23
67F-43111-00-8D	21 - 1	67F-4385A-01	24 - 7	67F-44120-10	20 - 14	67F-45180-00-4D	23 - 1	6E5-45941-00	29 - 25	701-48248-00	34 - 13
67F-43112-00-8D	21 - 4	67F-43861-00	24 - 15	67F-44120-30	20 - 14	67F-45181-00-CA	26 - 16	6E5-45943-00	29 - 25	703-48252-00	34 - 12
6D8-43126-00	21 - 30	62X-43862-00	24 - 18	67F-44121-00	20 - 11	688-45211-01-8D	26 - 35	6E5-45945-01	29 - 25	703-48261-01	34 - 2
64E-43131-01	21 - 12	67F-43862-00	24 - 6	68V-44122-01	20 - 8	6H1-45214-00	29 - 10	6E5-45947-00	29 - 25	703-48264-00	34 - 6
64E-43139-10	22 - 4		24 - 30	67F-44135-00	20 - 30	6H1-45215-00	29 - 11	6E5-45949-00	29 - 25	703-48265-00	34 - 9
64D-43144-00	19 - 14	67F-43863-00	24 - 26	67F-44150-01	28 - 40	6H1-45251-03	21 - 39	6E5-45952-00	29 - 25	703-48268-00	34 - 5
66T-43144-00	21 - 24	6D8-43863-00	24 - 5	67F-44311-01	28 - 17	6D9-45300-12-8D	28 - 1	6E5-45954-00	29 - 25	703-48271-00	34 - 61
6E5-43145-01	32 - 8		24 - 17	6D8-44314-00	29 - 3	6D9-45300-32-8D	28 - 1	6E5-45956-00	29 - 25	6Y8-48277-00	36 - 16
6G5-43148-00	21 - 21		24 - 86	688-44315-A0	28 - 27	67F-45301-00-8D	28 - 2	6E5-45958-00	29 - 25	703-48281-00	34 - 31
6D8-43181-00	21 - 18	62X-43865-00	24 - 32		38 - 3	67F-45318-00	26 - 23	688-45970-03	29 - 25	703-48282-00	34 - 32
6D8-43185-00	21 - 19	65W-4386A-00	24 - 20		38 - 25	688-45321-00	28 - 35	688-45972-02	29 - 25	703-48284-00	34 - 53
6D8-43311-00-8D	21 - 7	6T4-4386A-00	24 - 34	688-44316-A0	28 - 34	67F-45331-00-CA	28 - 61	688-45974-02	29 - 25	703-48284-10	34 - 53
6D8-43800-01-8D	24 - 1	6C6-4386E-00	24 - 78		38 - 7	688-45341-10	28 - 4	688-45976-01	29 - 25	701-48287-00	34 - 42
6D8-43804-01	25 - 3	688-4386F-00	24 - 21		38 - 28	67F-45371-00	29 - 14	688-45978-60	29 - 25	703-48291-10	34 - 39
6D8-43805-01	25 - 2	6C6-4386G-00	24 - 77	67F-44322-00	28 - 24	688-45375-00	29 - 18	688-45987-01	29 - 20	703-48293-10	34 - 41
62X-43807-00	25 - 7	62X-4386K-00	25 - 9		38 - 23	663-45376-00	29 - 19	67F-45997-00	29 - 21	701-48320-30	33 - 2
6H1-4380F-11	25 - 8	62X-43871-00	24 - 9	67F-44323-00	28 - 28	6E5-45378-00	28 - 6	67F-46241-00	5 - 15	701-48320-70	33 - 2
6C5-4380G-00	24 - 47	67F-43871-00	24 - 31		38 - 26	688-45383-02	28 - 67	703-48152-00	34 - 58	663-48344-00	20 - 3
6D8-4380K-00	24 - 43	6C5-43872-00	24 - 83	688-44324-A0	28 - 29	688-45384-02	28 - 68	703-48153-00	34 - 3		20 - 23
67F-4380R-00	24 - 3	6H1-43872-10	24 - 4		38 - 4	67F-45501-10	28 - 10	703-48189-00	34 - 17	703-48345-01	34 - 19

NUMERICAL INDEX
INDICE NUMERICO

PART NO. CODIGO N°	REF. NO.	PART NO. CODIGO N°	REF. NO.	PART NO. CODIGO N°	REF. NO.	PART NO. CODIGO N°	REF. NO.	PART NO. CODIGO N°	REF. NO.	PART NO. CODIGO N°	REF. NO.
701-48350-00	33 - 2	68V-81942-03	15 - 28	703-82510-12	34 - 44	67F-83614-00	17 - 15	90109-06M86	19 - 23	90167-06002	19 - 38
703-48358-00	34 - 20	68V-81948-02	15 - 17	703-82510-43	34 - 44	6D8-83626-00	4 - 35		19 - 31	90167-06M00	36 - 12
67F-48511-00	22 - 35	61A-81949-00	15 - 16	6Y8-82521-11	36 - 15	67F-83627-01	18 - 34		19 - 39	90170-09M03	32 - 4
67F-48538-00	20 - 1	68V-8194A-00	15 - 7	6D8-8252H-01	17 - 18	6Y5-83653-30	35 - 15		20 - 2	90170-16M01	28 - 12
67F-61350-00	32 - 1	60E-81950-00	15 - 5	60E-82531-00	34 - 47	67H-83672-01	22 - 1	90109-06M96	19 - 18	90170-40008	5 - 22
6C5-81145-00	6 - 7	63P-81950-00	15 - 12	6K1-82532-00	34 - 46	68F-83688-00	6 - 17	90109-12007	22 - 18	90171-16011	29 - 23
6C5-81146-00	6 - 12	68V-81953-00	15 - 8	703-82532-00	34 - 46	6Y8-8454G-00	36 - 11	90109-12012	22 - 26	90179-06M24	1 - 11
445-81328-20	13 - 7	6D8-81960-10	14 - 24	703-82540-00	34 - 51	689-85547-00	11 - 1	90110-12M00	23 - 4	90179-08003	18 - 27
6D8-8132G-00	17 - 1	6AH-81994-40	13 - 25	703-82542-00	34 - 64	6D8-85547-00	13 - 20	90116-10175	22 - 36	90179-24002	13 - 15
6D8-81332-00	13 - 16	6AH-81994-50	13 - 26	6D8-82544-00	7 - 25	6D8-85580-00	13 - 3	90116-10M05	26 - 31	90183-02M03	28 - 49
6D8-81337-00	13 - 18	6AH-81994-70	13 - 25	682-82556-00	34 - 49	68V-85753-00	17 - 6	90119-06087	7 - 8	90185-05002	29 - 13
63D-81345-20	13 - 5	6AH-81995-40	13 - 23	703-82563-02	34 - 56		37 - 7		7 - 12	90185-09M01	32 - 3
6D8-81410-00	13 - 4	6AH-81995-50	13 - 24	63D-82563-10	17 - 13	67F-85757-00	17 - 5	90119-06113	7 - 17	90185-10051	22 - 37
6D8-81450-00	13 - 1	6AH-81995-70	13 - 23	703-82563-12	34 - 56	67F-85790-00	17 - 4	90119-06M08	8 - 1	90185-22M11	21 - 15
6D8-81460-00	13 - 2	6AG-81996-00	13 - 27	688-82575-01	34 - 48	6C5-85885-00	6 - 6	90119-06M59	8 - 28	90201-03313	28 - 48
6D8-81518-00	15 - 23	68V-82105-00	15 - 1	676-82577-00	34 - 45	6D6-8591A-13	14 - 1		14 - 4	90201-06068	19 - 12
6D8-81528-02	15 - 24	6Y5-82117-00	35 - 14	703-82577-00	34 - 45	6D7-8591A-13	14 - 1		15 - 20	90201-06M30	36 - 13
68V-81673-00	13 - 8	6G5-82119-00	15 - 11	6D8-82581-01	16 - 15	6D8-8591A-13	14 - 1	90119-06M81	21 - 40	90201-06M31	20 - 37
68V-81800-01	18 - 1	682-82119-01	15 - 30	68F-82582-00	18 - 29	6D9-8591A-13	14 - 1	90119-06M83	11 - 30	90201-06M62	20 - 27
67F-81801-00	18 - 5	67F-82127-00	21 - 11	6P2-82582-00	16 - 6	6D8-8591A-23	14 - 1	90119-06MA2	2 - 33	90201-09M02	20 - 16
67F-81807-00	18 - 10	6D8-82148-00	21 - 27	6Y8-86260-11	16 - 7	6Y8-86260-11	36 - 2	90119-06MA4	2 - 19	90201-10M02	20 - 28
67F-81808-00	18 - 8	6E5-82148-00	21 - 5	6E5-82587-00	17 - 14	6AA-86261-21	36 - 3	90119-07234	4 - 7		20 - 38
67F-81809-00	18 - 19	1E6-82151-00	35 - 13	6E5-82588-00	19 - 28	6Y8-86267-00	36 - 1	90119-07235	4 - 5	90201-10M20	32 - 2
67F-81810-00	18 - 3		35 - 13	61A-82588-01	20 - 46	6Y5-87122-S0	35 - 11	90119-08069	7 - 1	90201-10M63	32 - 6
67F-81813-00	18 - 6	67F-82151-00	16 - 2	6D8-82588-01	16 - 12	6C5-87226-00	9 - 11	90119-08091	22 - 17	90201-12426	21 - 47
68F-81820-00	18 - 7	67F-82151-10	16 - 3	688-8258A-10	16 - 29	K1C-A3275-00	3 - 6	90119-08M03	7 - 3	90201-12M01	23 - 2
67F-81821-00	18 - 13	67F-8215B-10	16 - 4	688-8258A-20	34 - 50	K0A-A3721-00	5 - 7	90119-08M13	28 - 20	90201-12M16	22 - 20
6K7-81826-11	18 - 24	67F-8215B-20	16 - 5	6D8-82590-30	16 - 1	K0A-A3722-00	5 - 8		38 - 31		22 - 27
67F-81828-00	18 - 25	6H1-82181-10	25 - 6	703-82591-00	34 - 54	6D8-W0001-02	37 - 1	90119-08M22	19 - 2		23 - 5
6C5-8182L-00	6 - 8	63P-82310-01	14 - 5		34 - 54	67F-W0001-21	38 - 1	90119-08M58	26 - 36	90201-13M01	21 - 46
67F-81830-00	18 - 17	68V-82317-00	14 - 2	703-82592-00	34 - 55	6D6-W0070-00	1 - 16	90119-08M66	2 - 5		22 - 21
67F-81832-00	18 - 11	6A0-82317-00	15 - 18	68V-82594-00	15 - 21	67F-W0078-00	38 - 22	90119-08M84	29 - 9	90201-13M03	22 - 25
67F-81836-00	18 - 12		15 - 31	703-82594-00	34 - 25	6D8-W009A-03-9S	4 - 1	90119-08M86	29 - 9	90201-13M19	22 - 30
67F-81839-00	18 - 21	663-82317-01	13 - 21	60V-8259F-00	20 - 45	6D9-W009A-03-9S	4 - 1	90119-08M87	28 - 19	90201-24014	13 - 14
67F-8183R-00	18 - 16	67F-82341-00	14 - 6	6X4-83383-00	36 - 5	6D8-W009B-05-9S	2 - 1		38 - 30	90201-24M02	22 - 28
60V-8183T-00	18 - 18	67F-82342-00	14 - 7	703-83383-11	34 - 52	6D8-W1164-21	3 - 5	90119-08M91	4 - 17	90201-25M05	28 - 59
68F-81840-00	18 - 4	67F-82343-00	14 - 10	703-83383-B0	34 - 52	6D8-W1164-31	3 - 5	90119-10049	22 - 34	90201-26M59	21 - 14
67F-81841-00	18 - 14	67F-82344-00	14 - 11	6X4-83386-00	36 - 6	90101-09M01	32 - 7	90119-10050	5 - 14	90201-30M00	22 - 9
67F-81842-00	18 - 20	67F-82361-00	14 - 8	6Y5-8350T-90	35 - 1	90101-12M03	21 - 45	90119-10M08	26 - 21	90202-07M07	20 - 9
67F-81846-00	18 - 26		14 - 12	6Y5-83533-T2	35 - 9	90101-12M77	21 - 45	90119-10M72	5 - 20	90202-25M04	22 - 29
67F-81850-00	18 - 2		14 - 14	6Y5-83553-00	35 - 12	90105-06M07	2 - 37	90119-10M88	2 - 4	90206-10M04	20 - 29
67F-81857-00	18 - 9	67F-82362-00	14 - 9	6Y5-83553-M0	35 - 12		4 - 11	90151-05M00	29 - 12		20 - 39
67F-81869-00	18 - 23		14 - 13	6Y5-83557-10	35 - 16	90105-10M67	29 - 15	90155-10005	4 - 16	90206-15M18	19 - 11
67F-81891-00	18 - 15	6D8-82388-01	14 - 18	6E5-83558-00	29 - 17	90109-06M80	19 - 49	90157-05M19	30 - 4	90249-06M19	21 - 23
6D8-81919-00	15 - 36	6D8-82389-01	16 - 18	6E5-83558-10	28 - 8	90109-06M81	19 - 29	90159-05059	22 - 5	90250-07M02	28 - 51
6D8-81919-10	15 - 37	6D8-82398-01	16 - 21	6Y5-8355X-T1	35 - 5	90109-06M82	19 - 8	90159-06M28	19 - 48	90280-04008	5 - 23
60V-81925-00	18 - 28	68V-82504-00	17 - 12		35 - 10	90109-06M86	17 - 16	90159-06M29	4 - 27	90280-04M04	28 - 26
68V-81941-01	18 - 22	6Y8-82509-10	36 - 8	6Y5-83570-S5	35 - 6		19 - 15	90160-04006	28 - 23		38 - 32

NUMERICAL INDEX
INDICE NUMERICO

PART NO. CODIGO N°	REF. NO.	PART NO. CODIGO N°	REF. NO.	PART NO. CODIGO N°	REF. NO.	PART NO. CODIGO N°	REF. NO.	PART NO. CODIGO N°	REF. NO.	PART NO. CODIGO N°	REF. NO.
90280-05015	13 - 13	90445-07ME0	29 - 16	90465-11M59	7 - 20	92903-08600	18 - 31	92995-06600	26 - 8	93315-52563	28 - 13
90282-04010	28 - 66	90445-13015	11 - 4	90465-12M03	7 - 22	92907-04600	4 - 21		26 - 11	93317-322V0	28 - 54
90340-08002	28 - 3	90445-13M01	12 - 2	90465-12M53	15 - 32	92990-04100	35 - 3		26 - 13	93317-325U0	28 - 62
90340-14M06	2 - 6		12 - 7	90465-13M11	16 - 28		35 - 7		27 - 25	93332-000U3	28 - 15
	27 - 3		30 - 9	90465-13M18	15 - 35	92990-06100	1 - 3		28 - 38	93332-000UD	28 - 55
90340-18M09	2 - 14	90445-13M27	11 - 4		16 - 24	92990-08600	34 - 34	92995-08100	21 - 17	93410-18M05	21 - 33
90344-51019	4 - 4	90445-13M35	12 - 9		35 - 18	92990-10100	26 - 33	92995-10100	29 - 7		21 - 38
90386-06M12	20 - 12		30 - 11	90467-09M03	8 - 17	92995-06100	13 - 11	92995-10600	26 - 32	93410-28M06	22 - 15
90386-08001	7 - 15	90445-13M37	11 - 4	90467-20M15	2 - 42		14 - 16		29 - 8	93420-36M01	26 - 24
90386-10M16	21 - 20	90445-15M03	5 - 18		7 - 21		14 - 27	92A08-03012	24 - 85	93430-06024	34 - 10
90386-15M73	19 - 10	90462-06018	19 - 34	90468-18008	20 - 4		14 - 30	92A08-03110	24 - 68	93450-44166	28 - 31
90386-18001	21 - 32	90462-10027	20 - 7		20 - 10		16 - 10	93101-25M03	28 - 32	93501-04M02	20 - 20
90386-18M35	21 - 31	90464-08004	14 - 19		20 - 13		16 - 26		28 - 63	93501-08001	24 - 10
90386-18MA0	21 - 36	90464-10010	2 - 23		20 - 24		19 - 36		38 - 5		24 - 19
90386-25M31	21 - 13	90464-11009	2 - 24	90480-06M19	12 - 4		20 - 32	93101-48001	3 - 10		24 - 27
90386-30M60	22 - 13	90464-12M58	15 - 22	90480-09M12	9 - 27		21 - 43		37 - 10	93503-16003	24 - 25
90386-30M77	22 - 12	90464-15007	8 - 2	90480-10M23	8 - 26	92995-06200	19 - 37	93102-08414	25 - 13		28 - 43
90386-30M78	22 - 10	90464-16001	2 - 46	90480-12072	4 - 22	92995-06600	1 - 7	93102-38008	5 - 24	93505-32038	24 - 54
90386-90M90	20 - 15	90464-18004	2 - 22	90480-12314	13 - 19		2 - 10		37 - 4	93602-07244	24 - 11
90387-06013	20 - 36	90464-18246	6 - 18	90480-13M24	15 - 25		4 - 25	93102-48008	3 - 9	93604-10M03	28 - 18
90387-06119	14 - 3		19 - 22		19 - 50		4 - 32		37 - 9	93604-12M07	27 - 26
	15 - 19	90464-30003	14 - 25	90480-14329	14 - 20		7 - 7	93106-09014	28 - 36	93605-10108	5 - 12
90387-06263	27 - 10		17 - 17	90480-19M06	28 - 22		7 - 11		38 - 8	93606-12019	2 - 3
90387-06M05	15 - 33	90464-76001	7 - 18	90480-20M05	2 - 30		7 - 24	93210-04279	36 - 9		26 - 30
90387-06M21	20 - 26		16 - 8	90480-22M15	19 - 3		8 - 5	93210-07003	28 - 41		27 - 6
90387-06M43	19 - 51	90465-06M86	17 - 9	90501-12082	20 - 21		8 - 13		38 - 10		29 - 5
90387-06M60	8 - 27	90465-08M23	14 - 21	90501-12M48	28 - 47		8 - 24	93210-08287	12 - 12	93606-19M23	26 - 14
90387-06M69	9 - 26		19 - 30	90501-16M11	2 - 29		11 - 15		30 - 14	93608-16M16	26 - 3
90387-07013	7 - 16	90465-08M63	21 - 9	90506-14M24	21 - 26		13 - 12	93210-09165	24 - 89		26 - 22
90387-08033	7 - 2		22 - 3	90506-16M34	19 - 16		14 - 17	93210-16275	32 - 9	93700-06M03	21 - 8
90387-08M37	19 - 4	90465-10M77	21 - 2	90506-16M39	5 - 17		14 - 23	93210-19MJ1	27 - 27	94702-00391	4 - 36
90387-10M42	32 - 5	90465-11M10	2 - 21	91318-03005	24 - 80		14 - 28		38 - 15	95302-03600	24 - 69
90387-18M01	21 - 35		2 - 27	91318-03016	24 - 74		14 - 31	93210-24M79	4 - 34	95333-08600	18 - 32
90387-22M01	21 - 37		8 - 7	91318-04030	24 - 73		15 - 27		37 - 2	95380-04600	35 - 4
90389-25M00	29 - 22		8 - 10	91318-05025	24 - 81		16 - 11	93210-29375	24 - 8		35 - 8
90401-20007	2 - 45		8 - 16	91318-05030	24 - 70		16 - 14	93210-29M94	22 - 11	95380-05600	20 - 44
90430-06M03	2 - 38		8 - 21	91318-05045	24 - 48		16 - 17	93210-30682	11 - 29		34 - 7
	4 - 12		10 - 16	91318-05050	24 - 94		16 - 20		37 - 13	95380-06600	1 - 4
90430-08020	28 - 5		11 - 3	91490-20015	20 - 17		16 - 23	93210-46044	28 - 33		19 - 47
	38 - 2		11 - 11	91490-40025	29 - 24		16 - 27		38 - 6		34 - 40
90430-14115	2 - 7		11 - 28	91609-50028	24 - 79		17 - 3		38 - 29	95380-08600	11 - 13
	37 - 5		19 - 44	91690-30020	21 - 22		17 - 8	93210-49046	28 - 39	95380-10600	26 - 34
90430-14M09	27 - 4		22 - 6	91690-50014	7 - 4		17 - 11		38 - 9	95380-12600	21 - 48
	38 - 12		22 - 7	91809-08006	4 - 6		17 - 20	93210-554A9	25 - 14	95380-12700	23 - 3
90430-18130	2 - 15		28 - 9	92903-06100	15 - 3		20 - 33	93210-64488	24 - 92	95380-12800	22 - 31
	37 - 11		35 - 17	92903-06600	15 - 4		20 - 41	93210-86M39	28 - 64	95780-06300	36 - 14
90445-07M31	28 - 7		36 - 10		15 - 15		21 - 29		38 - 11	95780-12300	22 - 23
90445-07M38	28 - 7	90465-11M59	2 - 41	92903-08100	18 - 33		21 - 44	93306-207U0	28 - 58		23 - 6

NUMERICAL INDEX
INDICE NUMERICO

PART NO. CODIGO N°	REF. NO.	PART NO. CODIGO N°	REF. NO.	PART NO. CODIGO N°	REF. NO.	PART NO. CODIGO N°	REF. NO.	PART NO. CODIGO N°	REF. NO.	PART NO. CODIGO N°	REF. NO.
95812-06025	27 - 9	97095-08020	21 - 16								
95895-06025	7 - 26	97380-05025	34 - 8								
95895-08014	26 - 29	97380-08030	34 - 33								
97013-06020	15 - 2	97575-06525	20 - 19								
	15 - 14		27 - 5								
97013-08045	18 - 30	97575-08540	2 - 39								
97075-06030	26 - 10		4 - 13								
97075-06050	26 - 12		26 - 2								
97075-06070	26 - 7	97595-06550	20 - 6								
97075-10040	29 - 6	97595-06610	15 - 10								
97095-06008	19 - 35		15 - 13								
97095-06010	8 - 12	97602-04216	25 - 11								
	21 - 3	97607-04110	13 - 6								
	21 - 10	97780-60620	15 - 9								
	21 - 25		36 - 7								
	21 - 28	97780-60625	15 - 6								
97095-06012	1 - 6		15 - 34								
	7 - 23	97880-06012	21 - 6								
	8 - 4	97880-06035	36 - 12								
	16 - 13	97885-06016	22 - 2								
	16 - 19	97980-05225	25 - 10								
	16 - 22	97980-06216	26 - 26								
	17 - 10		36 - 4								
	17 - 19	97985-04116	20 - 47								
97095-06014	14 - 22	97985-06210	13 - 17								
	15 - 26	98507-04008	4 - 20								
	16 - 16	98580-03015	34 - 38								
97095-06016	8 - 23	98580-04006	34 - 36								
	11 - 14	98580-04010	34 - 35								
	14 - 29	98580-05010	34 - 37								
	16 - 9	98780-04016	2 - 17								
	16 - 25	99001-08600	28 - 42								
	17 - 2	99530-08012	13 - 9								
	17 - 7	99530-14016	4 - 15								
	19 - 13	9E450-04533	35 - 2								
	21 - 42										
	28 - 37										
97095-06020	2 - 9										
	7 - 10										
97095-06025	4 - 31										
	14 - 15										
	14 - 26										
	20 - 40										
97095-06030	4 - 24										
	7 - 6										
	13 - 10										
97095-06035	20 - 31										
97095-06045	27 - 24										